

MM5452/MM5453

Liquid Crystal Display Drivers

General Description

The MM5452 is a monolithic integrated circuit utilizing CMOS metal gate, low threshold enhancement mode devices. It is available in a 40-pin molded package. The chip can drive up to 32 segments of LCD and can be paralleled to increase this number. The chip is capable of driving a 4½-digit 7-segment display with minimal interface between the display and the data source.

The MM5452 stores display data in latches after it is clocked in, and holds the data until new display data is received.

Features

- Serial data input
- No load signal required

- DATA ENABLE (MM5452)
- Wide power supply operation
- TTL compatibility
- 32 or 33 outputs
- Alphanumeric and bar graph capability
- Cascaded operation capability

Applications

- COPS™ or microprocessor displays
- Industrial control indicator
- Digital clock, thermometer, counter, voltmeter
- Instrumentation readouts
- Remote displays

Block Diagram

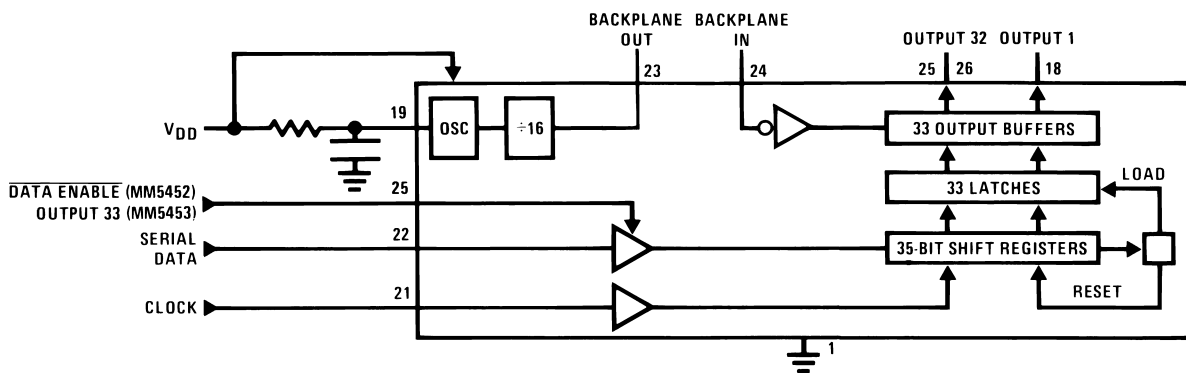

00613701

FIGURE 1.

Absolute Maximum Ratings (Note 1)

If Military/Aerospace specified devices are required, please contact the National Semiconductor Sales Office/Distributors for availability and specifications.

Voltage at Any Pin, Referenced to Gnd	-0.3V to +10V
Storage Temperature	-65°C to +150°C
Power Dissipation at 25°C	350mW
Power Dissipation at 70°C	300mW
Junction Temperature	+150°C

Lead Temperature (Soldering, 10s) 300°C

Recommended Operating Conditions

V_{DD}	3V to 10V
Operating Temperature	-40°C to 85°C

Electrical Characteristics T_A within operating range, $V_{DD} = 3.0V$ to $10V$, $V_{SS} = 0V$ unless otherwise specified.

Parameter	Conditions	Min	Typ	Max	Units
Supply Voltage, V_{DD}		3		10	V
Average Supply Current, I_{DD}	All Outputs Open, Clock=Gnd, Data=Gnd, OSC=Gnd, BP_IN @ 32Hz				
	$V_{DD} = 5V$			10	μA
	$V_{DD} = 10V$			40	μA
Input Logical '0' Voltage, V_{IL}	$V_{DD} = 3V$			0.4	V
	$V_{DD} = 5V$			0.8	V
	$V_{DD} = 10V$			0.8	V
Input Logical '1' Voltage, V_{IH}	$V_{DD} = 3V$	2.0			V
	$V_{DD} = 5V$	2.0			V
	$V_{DD} = 10V$	8.0			V
Segment Sink Current, I_{OL}	$V_{DD} = 3V$, $V_{OUT} = 0.3V$	-20	-40		μA
Segment Source Current, I_{OH}	$V_{DD} = 3V$, $V_{OUT} = 2.7V$	20	40		μA
Backplane Out Sink Current, I_{OL}	$V_{DD} = 3V$, $V_{OUT} = 0.3V$	-320	-500		μA
Backplane Out Source Current, I_{OH}	$V_{DD} = 3V$, $V_{OUT} = 2.7V$	320	500		μA
Segment Output Offset Voltage	Segment Load = 250pF (Note 2)			+/-50	mV
Backplane Output Offset Voltage	Backplane Load = 8750pF (Note 2)			+/-50	mV
Backplane Out Frequency	$R_{OSC_IN} = 50k\Omega$, $C_{OSC_IN} = 0.01\mu F$		75		Hz
Clock Input Frequency, f_{CLOCK}	$V_{DD} = 3V$ (Notes 2, 3)			500	kHz
	$V_{DD} = 5V$ (Note 2)			750	kHz
	$V_{DD} = 10V$ (Note 2)			1.0	MHz
Clock Input Duty Cycle		40		60	%
Data Input Set-Up Time, t_{DS}		300			ns
Data Input Hold Time, t_{DH}		300			ns
DataEnable Set-up Time, t_{DES}		100			ns

Note 1: "Absolute Maximum Ratings" are those values beyond which the safety of the device cannot be guaranteed. They are not meant to imply that the devices should be operated at these limits. The table of "Electrical Characteristics" specifies conditions of device operation.

Note 2: This parameter is guaranteed (but not production tested) over the operating temperature range and the operating supply voltage range. Not to be used in Q.A. testing.

Note 3: AC input waveform for test purposes: $t_r \leq 20ns$, $t_f \leq 20ns$, $f_{CLOCK} = 500kHz$, Duty Cycle = 50% $\pm 10\%$

Note 4: Clock input rise time (t_r) and fall time (t_f) must not exceed 300ns

Connection Diagrams

Dual-In-Line Package

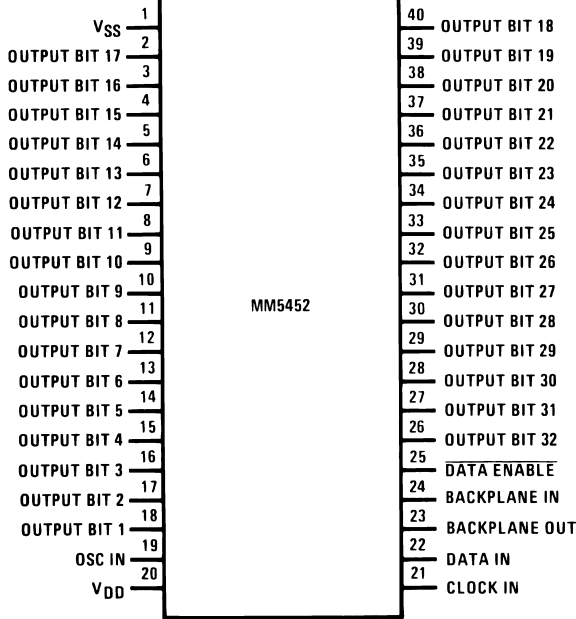

00613702

Top View

FIGURE 2.

Dual-In-Line Package

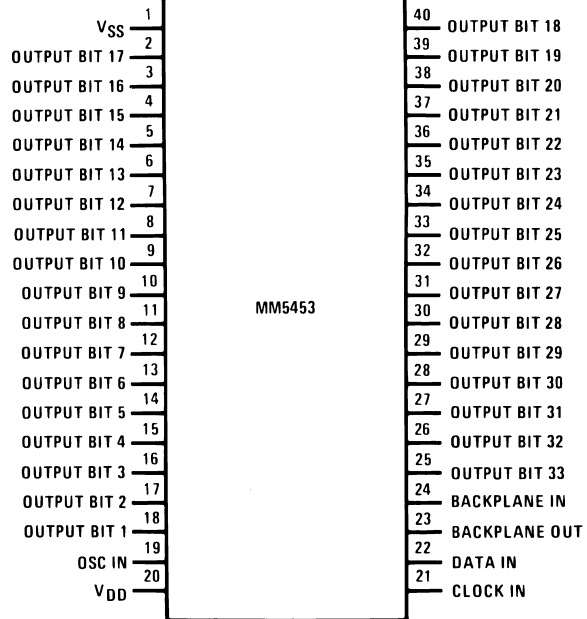

00613703

Top View

FIGURE 3.

Plastic Chip Carrier

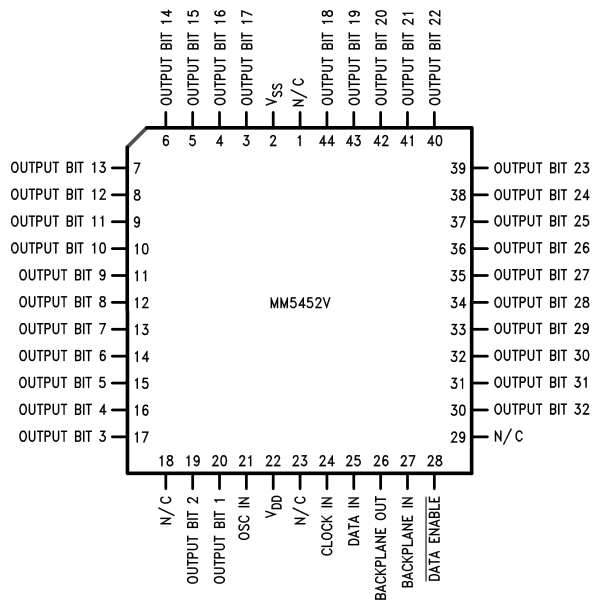

00613711

Top View

Plastic Chip Carrier

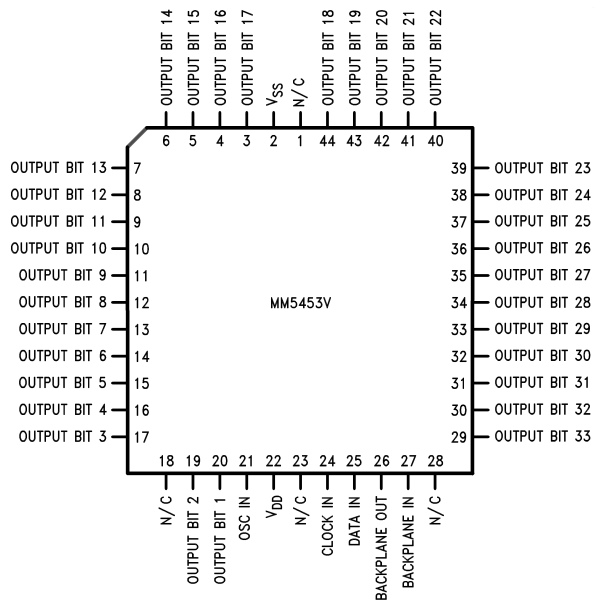

00613712

Top View

Order Number MM5452N, MM5453N, MM5452V or MM5453V
See NS Package Number N40A or V44A

Functional Description

The MM5452 is specifically designed to operate 4½-digit 7-segment displays with minimal interface with the display and the data source. Serial data transfer from the data source to the display driver is accomplished with 2 signals, serial data and clock. Since the MM5452 does not contain a character generator, the formatting of the segment information must be done prior to inputting the data to the MM5452. Using a format of a leading "1" followed by the 32 data bits allows data transfer without an additional load signal. The 32 data bits are latched after the 36th clock is complete, thus providing non-multiplexed, direct drive to the display. Outputs change only if the serial data bits differ from the previous time.

A block diagram is shown in *Figure 1*. For the MM5452 a $\overline{\text{DATA ENABLE}}$ is used instead of the 33rd output. If the $\overline{\text{DATA ENABLE}}$ signal is not required, the 33rd output can be brought out. This is the MM5453 device.

Figure 5 shows the input data format. A start bit of logical "1" precedes the 32 bits of data. At the 36th clock a LOAD signal is generated synchronously with the high state of the clock, which loads the 32 bits of the shift registers into the latches. At the low state of the clock a RESET signal is generated which clears all the shift registers for the next set of data. The shift registers are static master-slave configuration. There is no clear for the master portion of the first shift register, thus allowing continuous operation.

If the clock is not continuous, there must be a complete set of 36 clocks otherwise the shift registers will not clear.

Figure 2 shows the pin-out of the MM5452. Bit 1 is the first bit following the start bit and it will appear on pin 18.

Figure 4 shows the timing relationships between data, clock and $\overline{\text{DATA ENABLE}}$.

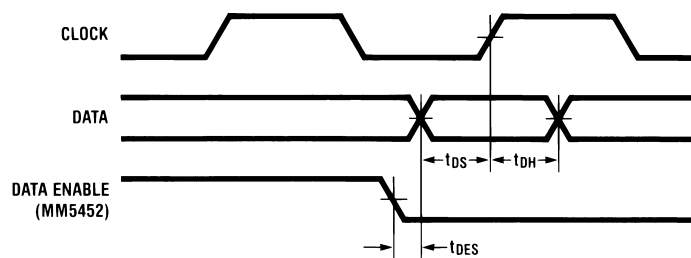

00613704

FIGURE 4.

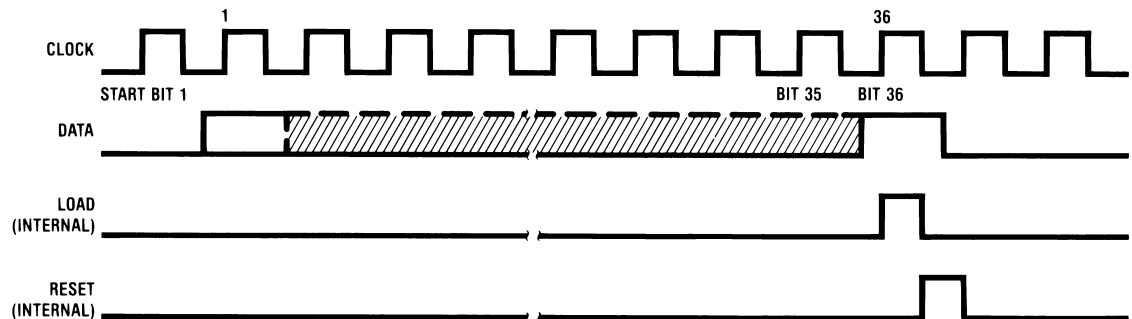

00613705

FIGURE 5. Input Data Format

Figure 6 shows a typical application. Note how the input data maps to the output pins and the display. The MM5452 and MM5453 do not have format restrictions, as all outputs are

controllable. The application assumes a specific display pinout. Different display/driver connection patterns will, of course, yield a different input data format.

Functional Description (Continued)

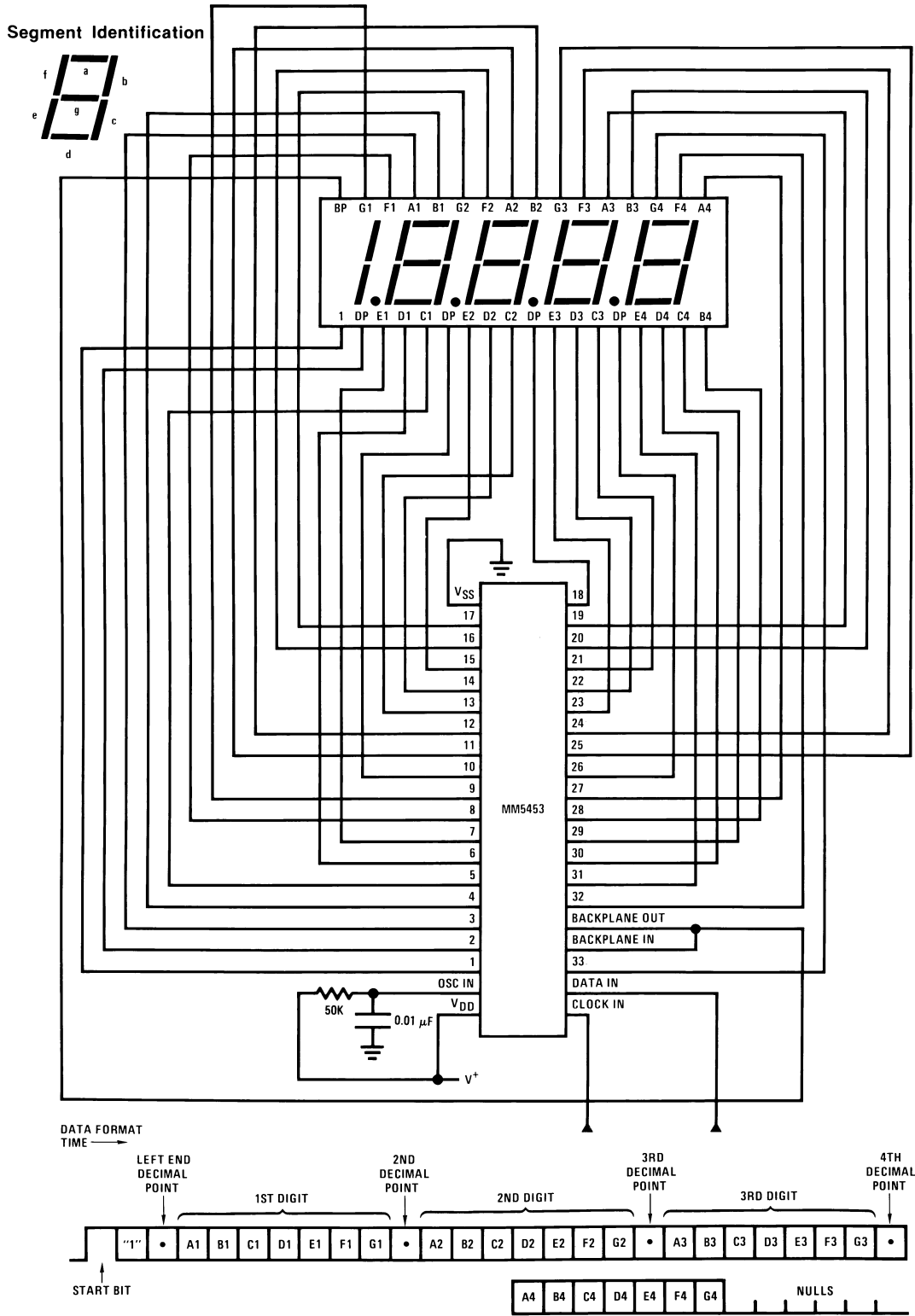

Consult LCD manufacturer's data sheet for specific pinouts.

00613706

FIGURE 6. Typical 4 1/2-Digit Display Application

Functional Description (Continued)

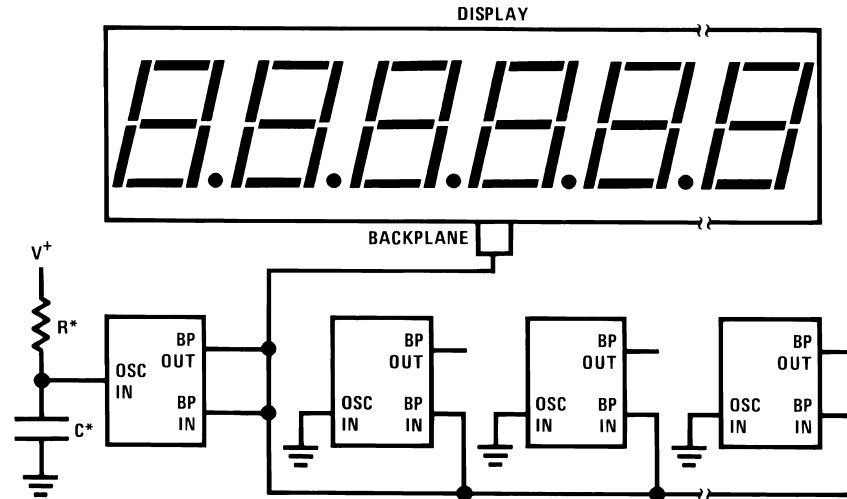

00613707

*The minimum recommended value for R for the oscillator input is 9 k Ω . An RC time constant of approximately 4.91×10^{-4} should produce a backplane frequency between 30 Hz and 150 Hz.

FIGURE 7. Parallel Backplane Outputs

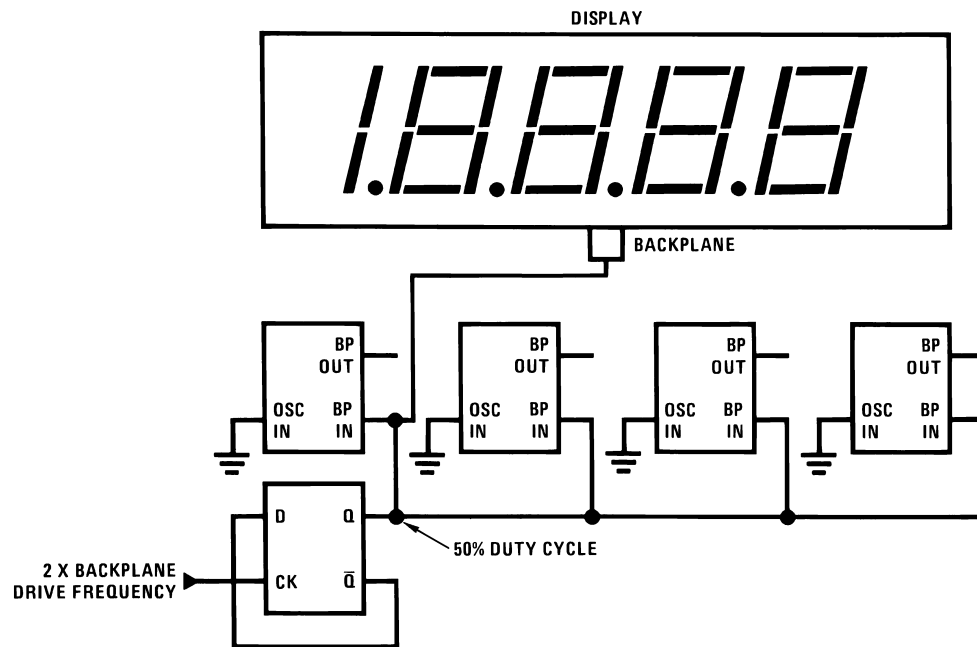

00613708

FIGURE 8. External Backplane Clock

Figure 9 shows a four wire remote display that takes advantage of the device's serial input to move many bits of display information on a few wires.

USING AN EXTERNAL CLOCK

The MM5452/MM5453 LCD Drivers can be used with an externally supplied clock, provided it has a duty cycle of 50%. Deviations from a 50% duty cycle result in an offset voltage on the LCD. In Figure 8, a flip-flop is used to assure

a 50% duty cycle. The oscillator input is grounded to prevent oscillation and reduce current consumptions in the chips. The oscillator is not used.

Using an external clock allows synchronizing the display drive with AC power, internal clocks, or DVM integration time to reduce interference from the display.

Figure 10 is a general block diagram that shows how the device's serial input can be used to advantage in an analog display. The analog voltage input is compared with a staircase voltage generated by a counter and a digital-to-analog

Functional Description (Continued)

converter or resistor array. The result of this comparison is clocked into the MM5452, MM5453. The next clock pulse increments the staircase and clocks the new data in.

With a buffer amplifier, the same staircase waveform can be used for many displays. The digital-to-analog converter need

not be linear; logarithmic or other non-linear functions can be displayed by using weighted resistors or special DACs. This system can be used for status indicators, spectrum analyzers, audio level and power meters, tuning indicators, and other applications.

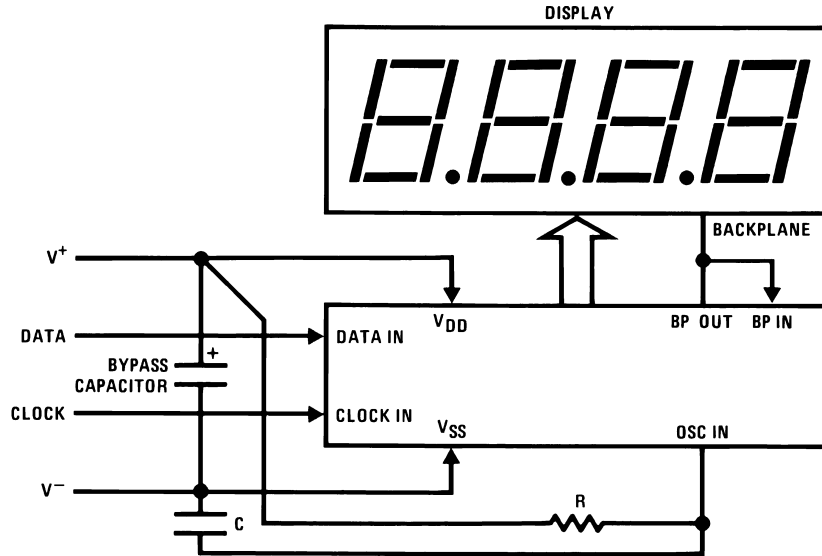

00613709

FIGURE 9. Four Wire Remote Display

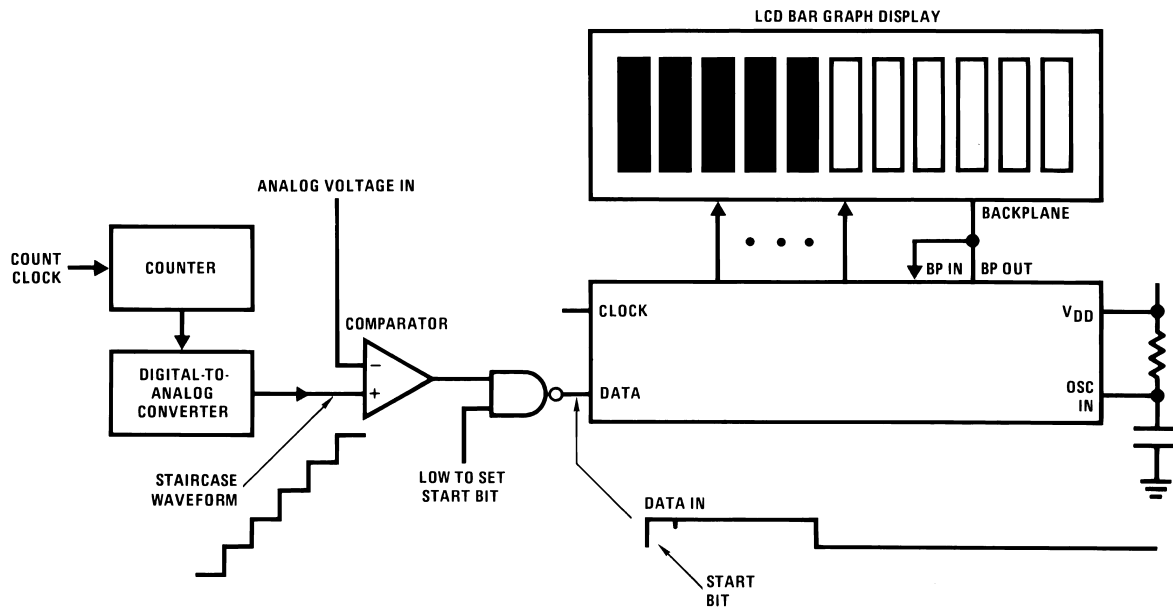

Data is high until staircase > input

00613710

FIGURE 10. Analog Display

Physical Dimensions inches (millimeters) unless otherwise noted

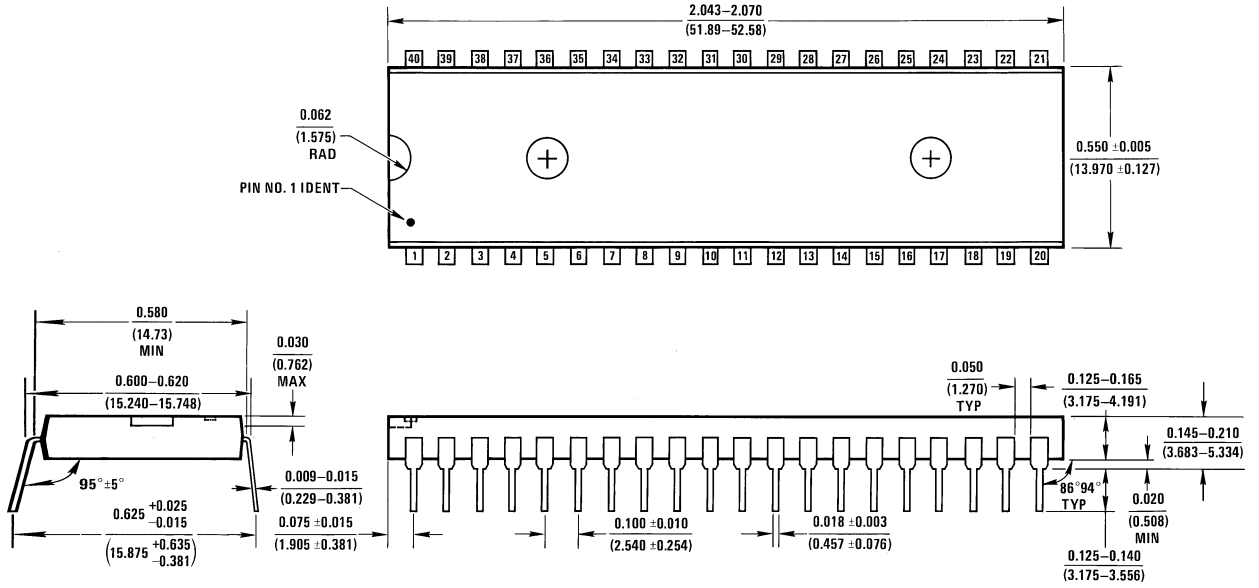

N40A (REV E)

Molded Dual-In-Line Package (N)
Order Number MM5452N or MM5453N
NS Package Number N40A

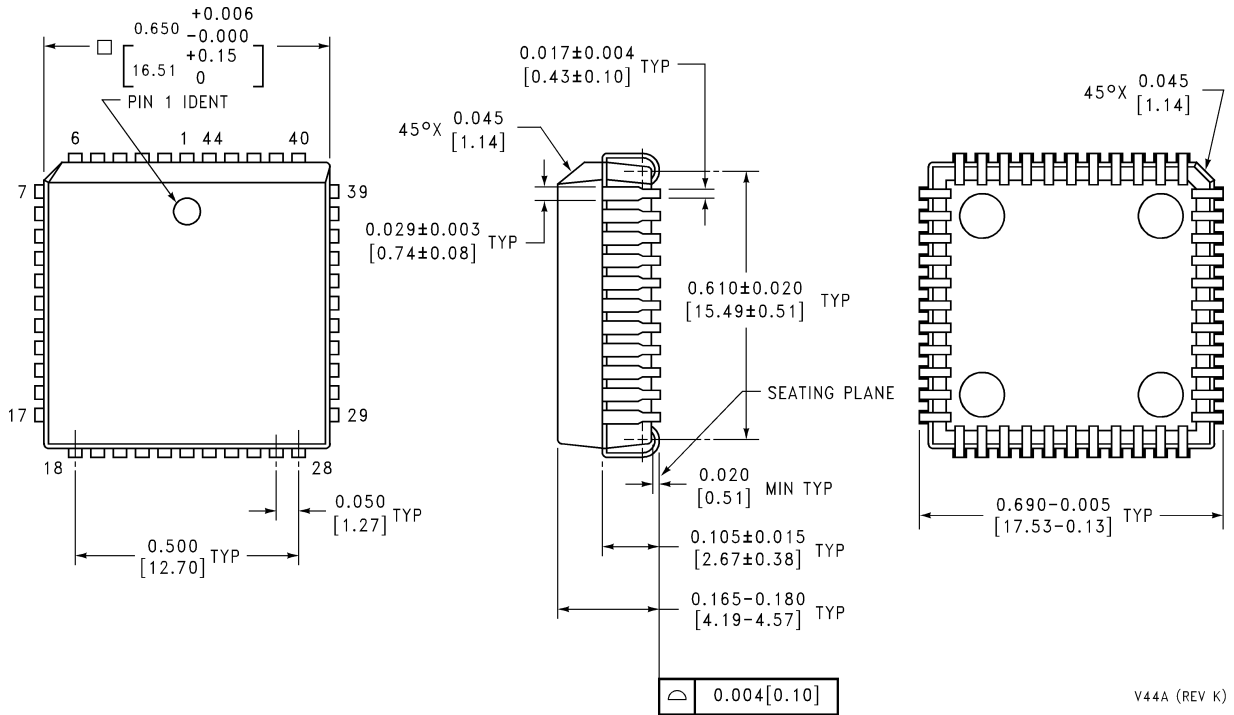

V44A (REV K)

Plastic Chip Carrier (V)
Order Number MM5452V or MM5453V
NS Package Number V44A

Notes

LIFE SUPPORT POLICY

NATIONAL'S PRODUCTS ARE NOT AUTHORIZED FOR USE AS CRITICAL COMPONENTS IN LIFE SUPPORT DEVICES OR SYSTEMS WITHOUT THE EXPRESS WRITTEN APPROVAL OF THE PRESIDENT AND GENERAL COUNSEL OF NATIONAL SEMICONDUCTOR CORPORATION. As used herein:

1. Life support devices or systems are devices or systems which, (a) are intended for surgical implant into the body, or (b) support or sustain life, and whose failure to perform when properly used in accordance with instructions for use provided in the labeling, can be reasonably expected to result in a significant injury to the user.
2. A critical component is any component of a life support device or system whose failure to perform can be reasonably expected to cause the failure of the life support device or system, or to affect its safety or effectiveness.



National Semiconductor Corporation
Americas
Email: support@nsc.com

www.national.com

National Semiconductor Europe

Fax: +49 (0) 180-530 85 86
Email: europe.support@nsc.com
Deutsch Tel: +49 (0) 69 9508 6208
English Tel: +44 (0) 870 24 0 2171
Français Tel: +33 (0) 1 41 91 8790

National Semiconductor Asia Pacific Customer Response Group

Tel: 65-2544466
Fax: 65-2504466
Email: ap.support@nsc.com

National Semiconductor Japan Ltd.

Tel: 81-3-5639-7560
Fax: 81-3-5639-7507