

LMH0340, LMH0040, LMH0070, LMH0050 3 Gbps, HD, SD, DVB-ASI SDI Serializer and Cable Driver with LVDS Interface

General Description

The LMH0340 3 Gbps SDI Serializer is part of National's family of FPGA-Attach SER/DES products supporting 5-bit LVDS interfaces with FPGAs. An FPGA Host will format data with supplied IP such that the output of the LMH0340 is compliant with the requirements of DVB-ASI, SMPTE 259M-C, SMPTE 292M and SMPTE 424M standards.

The interface between the SER (Serializer) and the FPGA consists of a 5 bit wide LVDS data bus, an LVDS clock and an SMBus interface. The LMH0340 / LMH0040 / LMH0070 SER devices include an integrated cable driver which is fully compliant with all of the SMPTE specifications listed above. Refer to *Table 1* for a complete listing of single channel serializers currently offered in this family. The LMH0050 has a CML output driver that can drive a differential transmission line or interface to a cable driver.

The FPGA-Attach SER/DES family is supported by a suite of IP which allows the design engineer to quickly develop video applications using the SER/DES products. The SER is packaged in a physically small 48 pin LLP package.

Key Specifications

- Output compliant with SMPTE 424M, SMPTE 292M, SMPTE 259M-C and DVB-ASI
- Typical power dissipation: 440 mW
- 30 ps typical output jitter (HD, 3G)

Features

- LVDS Interface to Host FPGA
- No external VCO or clock ref required
- Integrated Variable Output Cable Driver
- 3.3V SMBus configuration interface
- Integrated TXCLK PLL cleans clock noise
- Small 48pin LLP package

Applications

- SDI interfaces for:
 - Video Cameras
 - DVRs
 - Video Switchers
 - Video Editing Systems

General Block Diagram

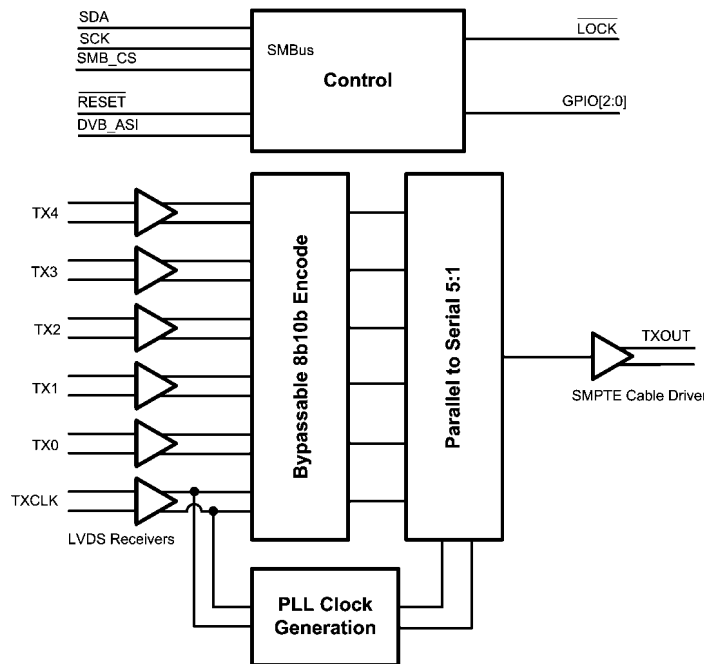

30017001

TRI-STATE® is a registered trademark of National Semiconductor Corporation.

Pin Descriptions

| Pin Name | Type | Description |
|---------------------------------------|----------------|-------------------------------------------------------------------------------------------------------------------------------------------------------|
| LVDS Input Interface | | |
| TX[4:0]+ TX[4:0]- | Input, LVDS | LVDS Data Input Pins Five channel wide DDR interface. Internal 100Ω termination. |
| TXCLK+ TXCLK- | Input, LVDS | LVDS Clock Input Pins DDR Interface. Internal 100Ω termination. |
| Serial Output Interface | | |
| TXOUT+ | Output, CML | Serial Digital Interface Output Pin Non-Inverting Output |
| TXOUT- | Output, CML | Serial Digital Interface Output Pin Inverting Output |
| SMBus Interface | | |
| SDA | I/O, LVCMOS | SMBus Data I/O Pin |
| SCK | Input, LVCMOS | SMBus Clock Input Pin |
| SMB_CS | Input, LVCMOS | SMBus Chip Select Input Pin Device is selected when High. |
| Control and Configuration Pins | | |
| RESET | Input, LVCMOS | Reset Input Pin H = normal mode L = device in RESET |
| LOCK | Output, LVCMOS | PLL LOCK Status Output H = unlock condition L = Device is Locked |
| DVB_ASI | Input, LVCMOS | DVB_ASI Select Input H = DVB_ASI Mode enabled L = Normal Mode enabled |
| GPIO[2:0] | I/O, LVCMOS | General Purpose Input / Output Software configurable I/O pins. |
| RSVD_H | Input, LVCMOS | Configuration Input – Must tie High Pull High via 5 kΩ resistor to V _{DD3V3} |
| Analog Inputs | | |
| R _{SET} | Input, analog | Serial Output Amplitude Control Resistor connected from this pin to ground to set the signal amplitude. Nominally 8.06kΩ for 800mV output (SMPTE). |
| LF_CP | Input, analog | Loop Filter Connection |
| LF_REF | Input, analog | Loop Filter Reference |
| DNC | | Do Not Connect – Leave Open |
| Power Supply and Ground | | |
| V _{DD3V3} | Power | 3.3V Power Supply connection |
| V _{DDPLL} | Power | 3.3V PLL Power Supply connection |
| V _{DD2V5} | Power | 2.5V Power Supply connection |
| GND | Ground | Ground connection – The DAP (large center pad) is the primary GND connection for the device and must be connected to Ground along with the GND pins. |

TABLE 1. Feature Table

| Device | SMPTE 424M Support (3G) | SMPTE 292M Support (HD) | SMPTE 259M Support (SD) | DVB-ASI Support | SMPTE compliant Cable Driver |
|---------|-------------------------|-------------------------|-------------------------|-----------------|------------------------------|
| LMH0340 | X | X | X | X | X |
| LMH0040 | | X | X | X | X |
| LMH0070 | | | X | X | X |
| LMH0050 | | X | X | X | |

Absolute Maximum Ratings (Note 1)

If Military/Aerospace specified devices are required, please contact the National Semiconductor Sales Office/Distributors for availability and specifications.

| | |
|--------------------------------|-------------------------------|
| Supply Voltage (V_{DD3V3}) | -0.3V to +4.0V |
| Supply Voltage (V_{DD2V5}) | -0.3V to +3.0V |
| LVC MOS input voltage | -0.3V to ($V_{DD3V3}+0.3V$) |
| LVC MOS output voltage | -0.3V to ($V_{DD3V3}+0.3V$) |

| | |
|------------------------------------|----------------|
| SMBus I/O voltage | -0.3V to +3.6V |
| LVDS Input Voltage | -0.3V to +3.6V |
| Junction Temperature | +150°C |
| Storage Temperature | -65° to 150°C |
| Thermal Resistance— | 25°C/W |
| Junction to Ambient— θ_{JA} | |
| ESD Rating—Human Body Model, | $\geq \pm 8kV$ |
| 1.5 K Ω , 100 pF | |

Recommended Operating Conditions

| Parameter | Min | Typ | Max | Units |
|-------------------------------------------------------------|-------|-----|-------|-------------------|
| Supply Voltage (V_{DD3V3} -GND) | 3.135 | 3.3 | 3.465 | V |
| Supply Voltage (V_{DD2V5} -GND) | 2.375 | 2.5 | 2.625 | V |
| Supply noise amplitude (10 Hz to 50 MHz) | | | 100 | mV _{P-P} |
| Ambient Temperature | -40 | +25 | +85 | °C |
| Case Temperature | | | 100 | °C |
| TXCLK input frequency – LMH0340 | 27 | | 297 | MHz |
| TXCLK input frequency – LMH0040 | 27 | | 149 | MHz |
| TXCLK input frequency – LMH0070 | 26.5 | 27 | 28 | MHz |
| TXCLK input frequency – LMH0050 | 27 | | 149 | MHz |
| LVDS PCB board trace length (mismatch <2%) | | | 25 | cm |
| Output Driver Pullup Resistor Termination Voltage (Note 10) | | 2.5 | 2.625 | V |

Electrical Characteristics

Over supply and Operating Temperature ranges unless otherwise specified. (Note 2)

| Symbol | Parameter | Condition | Min | Typ | Max | Units |
|-------------|------------------------------------------------------|----------------------|-----|-----|-----|-------|
| $I_{DD2.5}$ | 2.5V supply current for LMH0340, LMH0040, or LMH0070 | 2.97 Gbps | | 93 | 102 | mA |
| | | 1.485 Gbps | | 80 | 87 | mA |
| | | 270 Mbps | | 63 | 69 | mA |
| | 2.5V supply current for LMH0050 | 1.485 Gbps | | 87 | 95 | mA |
| | | 270 Mbps | | 70 | 75 | mA |
| $I_{DD3.3}$ | 3.3V supply current for LMH0340, LMH0040, or LMH0070 | 2.97 Gbps | | 73 | 85 | mA |
| | | 1.485 Gbps | | 73 | 85 | mA |
| | | 270 Mbps | | 73 | 85 | mA |
| | 3.3V supply current for LMH0050 | 1.485 Gbps | | 73 | 85 | mA |
| | | 270 Mbps | | 73 | 85 | mA |
| PD | Power Consumption | LMH0340 - 2.97 Gbps | | 475 | 545 | mW |
| | | LMH0040 - 1.485 Gbps | | 440 | 510 | mW |
| | | LMH0050 - 1.485 Gbps | | 460 | 525 | mW |
| | | LMH0050 - 270 Mbps | | 415 | 485 | mW |
| | | LMH0070 - 270 Mbps | | 400 | 470 | mW |

Control Pin Electrical Characteristics

Over supply and Operating Temperature ranges unless otherwise specified. Applies to DVB_ASI, \overline{RESET} , GPIO[2:0] and \overline{LOCK} . (Note 2)

| Symbol | Parameter | Condition | Min | Typ | Max | Units |
|----------|---------------------------|-------------------|-----|-------|-------------|-------|
| V_{IH} | High Level Input Voltage | | 2.0 | | V_{DD3V3} | V |
| V_{IL} | Low Level Input Voltage | | 0 | | 0.8 | V |
| V_{OH} | High Level Output Voltage | $I_{OH} = -2$ mA | 2.7 | 3.3 | | V |
| V_{OL} | Low Level Output Voltage | $I_{OL} = 2$ mA | | | 0.3 | V |
| V_{CL} | Input Clamp Voltage | $I_{CL} = -18$ mA | | -0.79 | -1.5 | V |

| Symbol | Parameter | Condition | Min | Typ | Max | Units |
|----------|------------------------------|---------------------------------|-----|-----|-----|---------|
| I_{IN} | Input Current | $V_{IN}=0.4V, 2.5V$ or V_{DD} | -35 | | 35 | μA |
| I_{OS} | Output Short Circuit Current | $V_{OUT}=0V$ | | -40 | | mA |

LVDS Input Electrical Characteristics

Over supply and Operating Temperature ranges unless otherwise specified. (Note 2)

| Symbol | Parameter | Condition | Min | Typ | Max | Units |
|------------|-----------------------------------|-----------------------------|------|-----|------|----------|
| V_{TH} | Differential Input High threshold | $0.05V < V_{CM} < 2.4V$ | | | +100 | mV |
| V_{TL} | Differential Input Low threshold | | -100 | | | mV |
| R_{LVIN} | Input Impedance | Measured between LVDS pairs | 85 | 100 | 115 | Ω |

LVDS Switching Characteristics

Over supply and Operating Temperature ranges unless otherwise specified. (Note 2)

| Symbol | Parameter | Condition | Min | Typ | Max | Units |
|-----------|-------------------------|-------------------------|------|-----|------|-------|
| t_{CIP} | TxCLKIN Period | See Figure 1 | 3.2 | 2T | 37 | ns |
| t_{CIT} | TxCLKIN Transition Time | See Figure 2 | 0.5 | 1.0 | 3.0 | ns |
| t_{CIH} | TxCLKIN IN High Time | See Figure 1 | 0.7T | T | 1.3T | ns |
| t_{CIL} | TxCLKIN IN Low Time | See Figure 1 | 0.7T | T | 1.3T | ns |
| t_{XIT} | TxIN Transition Time | | 0.15 | | 3 | ns |
| t_{STC} | TxIN Setup to TxCLKIN | See Figure 1, (Note 11) | -550 | | | ps |
| t_{HTC} | TxIN Hold to TxCLKIN | | 900 | | | ps |

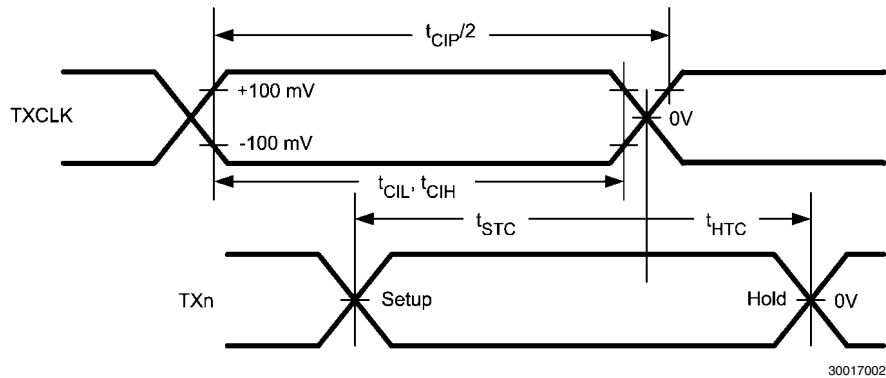

FIGURE 1. LVDS Input Timing Diagram



FIGURE 2. Transmit Clock Transition Times

SMBus Input Electrical Characteristics

Over supply and Operating Temperature ranges unless otherwise specified. (Note 2)

| Symbol | Parameter | Condition | Min | Typ | Max | Units |
|---------------|----------------------------------------------------|------------------------------|-------|------|-----------|----------|
| V_{SIL} | Data, Clock Input Low Voltage | | | | 0.8 | V |
| V_{SIH} | Data, Clock Input High Voltage | | 2 | | V_{SDD} | V |
| $I_{SPULLUP}$ | Current through pull-up resistor or current source | (Note 3) | 4 | | | mA |
| V_{SDD} | Nominal Bus Voltage | | 2.375 | | 3.6 | V |
| I_{SLEAKB} | Input Leakage per bus segment | (Note 3) | -200 | | 200 | μ A |
| I_{SLEAKP} | Input Leakage per pin | | -10 | | 10 | μ A |
| C_{SI} | Capacitance for SMBdata and SMBclk | (Notes 3, 4) | | | 10 | pF |
| R_{STERM} | Termination Resistance | V_{SDD3V3} (Notes 5, 4, 3) | | 1000 | | Ω |

SMBus Switching Characteristics

Over supply and Operating Temperature ranges unless otherwise specified. (Note 2)

| Symbol | Parameter | Condition | Min | Typ | Max | Units |
|--------------|---------------------------------------------------------------------------------------------|------------------------|-----|-----|------|---------|
| f_{SMB} | Bus Operating Frequency | | 10 | | 100 | kHz |
| t_{BUF} | Bus free time between stop and start condition | | 4.7 | | | μ s |
| $t_{HD:STA}$ | Hold time after (repeated) start condition. After this period, the first clock is generated | At $I_{SPULLUP} = MAX$ | 4.0 | | | μ s |
| $t_{SU:STA}$ | Repeated Start condition setup time | | 4.7 | | | μ s |
| $t_{SU:STO}$ | Stop Condition setup time | | 4.0 | | | μ s |
| $t_{HD:DAT}$ | Data hold time | | 300 | | | ns |
| $t_{SU:DAT}$ | Data setup time | | 250 | | | ns |
| t_{LOW} | Clock Low Time | | 4.7 | | | μ s |
| t_{HIGH} | Clock High Time | | 4.0 | | 50 | μ s |
| t_F | Clock/data fall time | 20% to 80% | | | 300 | ns |
| t_R | Clock/data rise time | | | | 1000 | ns |
| $t_{SU:CS}$ | SMB_CS setup time | | | 30 | | ns |
| t_{POR} | Time in which a device must be operational after power on | | | | 500 | ms |

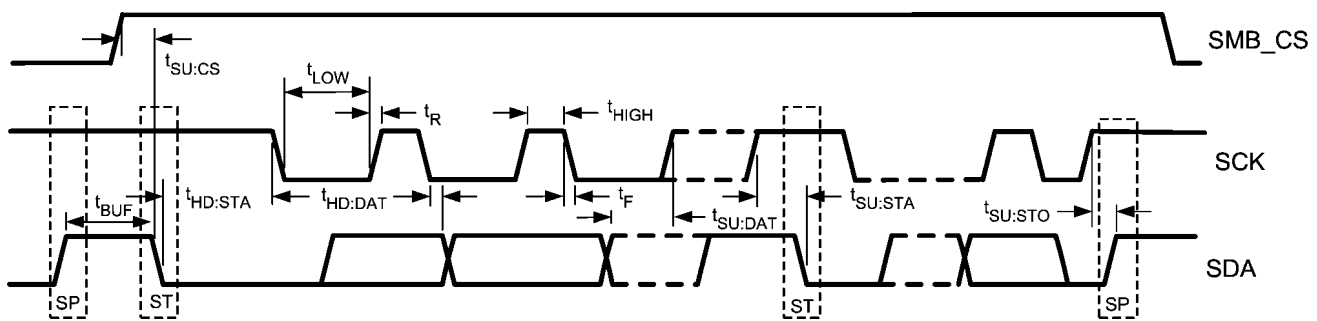

30017004

(levels are V_{SIL} and V_{SIH})

FIGURE 3. SMBus Timing Parameters

SDI Output Characteristics — LMH0340 / LMH0040 / LMH0070

Over supply and Operating Temperature ranges unless otherwise specified. (Note 2)

| Symbol | Parameter | Condition | Min | Typ | Max | Units |
|-----------------|-----------------------------------------------------|-------------------------------|-----|-----|-------|-------------|
| V _{OD} | SDI Output Voltage | into 75Ω load | 720 | 800 | 880 | mV |
| DR | SDI Output Datarate | LMH0340 | 270 | | 2,970 | Mbps |
| | | LMH0040 | 270 | | 1,485 | Mbps |
| | | LMH0070 | | 270 | | Mbps |
| t _r | SDI Output Rise Time | 2.97 Gbps | | 90 | 135 | ps |
| | | 1.485 Gbps | | 90 | 220 | ps |
| | | <1.485 Gbps | 400 | 700 | 1000 | ps |
| t _f | SDI Output Fall Time | 2.97 Gbps | | 90 | 135 | ps |
| | | 1.485 Gbps | | 90 | 220 | ps |
| | | <1.485 Gbps | 400 | 700 | 1000 | ps |
| Δt _t | Mismatch between rise and fall time | ≥1.485 Gbps (Note 9) | | | 30 | ps |
| t _{SD} | Propagation Delay Latency | See Figure 4 | | 9.5 | | TXCLK cycle |
| t _J | Peak to Peak Alignment Jitter | ≥1.485 Gbps(Note 6) | | 30 | 50 | ps |
| | | 270 Mbps(Note 6) | | 100 | 200 | ps |
| RL | Output Return Loss — EVK Specification (Note 12) | Measured 5 MHz to 1485 MHz | 15 | 20 | | dB |
| | | Measured 1485 MHz to 2970 MHz | 10 | 15 | | dB |
| t _{OS} | Output Overshoot (Note 9) | 2.97 Gbps | | | 8 | % |
| | | 1.485 Gbps | | | 5 | % |
| | | 270 Mbps | | | 2 | % |

CML Output Characteristics — LMH0050

Over supply and Operating Temperature ranges unless otherwise specified. (Note 2)

| Symbol | Parameter | Condition | Min | Typ | Max | Units |
|------------------|-------------------------------|--------------------------------------|------|-----|------|-------|
| V _{OD} | Output Voltage | into 100 Ω differential load | 1175 | | 1450 | mV |
| DR | Data Rate | | 270 | | 1485 | Mbps |
| t _r | Output Rise Time | | | | 100 | ps |
| t _f | Output Fall Time | | | | 100 | ps |
| t _J | Peak-to-Peak Alignment Jitter | 1.485 Gbps | | 25 | 50 | ps |
| R _{OUT} | Output Termination Resistance | Output Pin to V _{DD2V5} Pin | 40 | 50 | 60 | Ω |

Device Switching Characteristics

Over supply and Operating Temperature ranges unless otherwise specified. (Note 2)

| Symbol | Parameter | Condition | Min | Typ | Max | Units |
|------------|------------------|------------|-----|-----|-----|-------|
| t_{TPLD} | Device Lock Time | 2.97 Gbps | | | 10 | ms |
| | | 1.485 Gbps | | | 11 | ms |
| | | 270 Mbps | | | 15 | ms |

Note 1: "Absolute Maximum Ratings" are limits beyond which the safety of the device cannot be guaranteed. It is not implied that the device will operate up to these limits.

Note 2: Typical Parameters measured at $V_{DD3V3}=3.3V$, $V_{DD2V5}=2.5V$, $T_A=25^{\circ}C$. They are for reference purposes and are not production tested.

Note 3: Recommended value—Parameter is not tested.

Note 4: Recommended maximum capacitance load per bus segment is 400 pF.

Note 5: Maximum termination voltage should be identical to the device supply voltage.

Note 6: Measured in accordance with SMPTE RP184. 100% production tested.

Note 7: Register 0x30'h bits [7:5] is at default value of 011'b

Note 8: Measured with $R_{SET} = 8.06\ k\Omega$ and register 0x69'h at default value.

Note 9: Specification guaranteed by characterization.

Note 10: Applies to LMH0340, LMH0040, and LMH0070.

Note 11: Parameter uses default settings in registers: 0x24'h and 0x30'h.

Note 12: Output Return Loss specification applies to measurement on the EVK PCB (LMH0340 ALP Daughter Card) per SMPTE requirements.

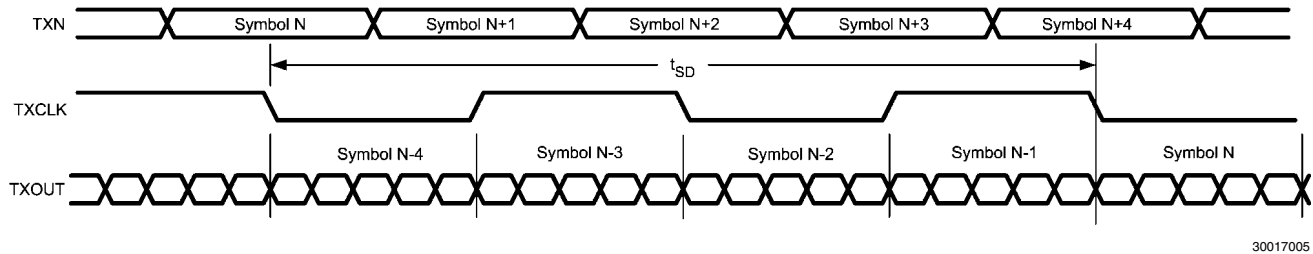

FIGURE 4. LVDS Interface Propagation Delay

Functional Description

DEVICE OPERATION

The SER is used in digital video signal origination equipment. It is intended to be operated in conjunction with an FPGA host which preprocesses data for it, and then provides this data over the five bit wide data path. Provided the host has properly formatted the data for the SER, the output of the device will be compliant with DVB-ASI, SMPTE 259M-C, SMPTE 292M or SMPTE 424M depending upon the output mode selected.

National Semiconductor offers IP in source code format to perform the appropriate formatting of the data, as well as evaluation platforms to assist in the development of target applications. For more information please contact your local National Semiconductor Sales Office/Distributor.

POWER SUPPLIES

The SER has several power supply pins, at 2.5V as well as 3.3V. It is important that these pins all be connected, and properly bypassed. Bypassing should consist of parallel 4.7 μ F and 0.1 μ F capacitors as a minimum, with a 0.1 μ F capacitor on each power pin. The device has a large contact in the center of the bottom of the package. This contact must be connected to the system GND as it is the major ground connection for the device. A 22 μ F capacitor is required on the V_{DDPLL} pin which is connected to the 3.3V rail.

Discrete bypassing is ineffective above 30 MHz to 50 MHz in power plane-based distribution systems. Above this frequency range, the intrinsic capacitance of the power-ground system can be used to provide additional RF bypassing. To make the best use of this, make certain that there are PCB layers dedicated to the Power supplies and to GND, and that they are placed next to each other to provide a distributed capacitance between power and GND.

The SER will work best when powered from linear regulators. The output of linear regulators is generally cleaner with less noise than switching regulators. Output filtering and power system frequency compensation are generally simpler and more effective with linear regulators. Low dropout linear regulators are available which can usually operate from lower input voltages such as logic power supplies, thereby reducing regulator power dissipation. Cascading of low dropout regulators should not be done since this places the entire supply current load of both load systems on the first regulator in the cascade and increases its loading and thermal output.

POWER UP

The 3.3V power supply should be brought up before the 2.5V supply. The timing of the supply sequencing is not important. The device has a power on reset sequence which takes place once both power supplies are brought up. This sequence will reset all register contents to their default values, and will place the PLLs into link acquisition mode, attempting to lock on the TXCLK input.

RESET

There are three ways in which the device may be reset. There is an automatic reset which happens on power-up; there is a reset pin, which when brought low will reset the device, with normal operation resuming when the pin is driven high again. The third way to reset the device is a soft reset, implemented via a write to the reset register. This reset will put all of the register values back to their default values, except it will not affect the address register value if the SMBus default address has been changed.

LVDS INPUTS

The SER has LVDS inputs that conform with the ANSI/TIA/EIA-644–A Standard. These inputs have an internal 100 Ω resistor across the inputs which allows for the closing of a current loop interface from the LVDS driver in the host. It is recommended that the PCB trace between the FPGA and the transmitter be less than 25cm. Longer PCB traces may introduce signal degradation as well as channel skew which could cause serialization errors. This connection between the host and the SER should be over a controlled impedance transmission line with an impedance which matches the termination resistor – usually 100 Ω . Setup and hold times are specified in the LVDS Switching Characteristics table, however there is the ability to change these by use of the CLK delay adjustment available via the SMBus, and writing to register 0x30'h.

LVDS DATA ORDER

When serializing the data, the data bit latched in on TX0 is output first, followed by TX1, TX2, TX3 and then TX4. If starting with a 10 bit word, T0..T9, with T0 being the LSB, and it is desired that this be serialized such that the LSB is sent out first, then the least significant 5 bit word would be provided to the serializer first, followed by the most significant word, and the resulting serialized output would have the LSB being sent first, and the 10 bit MSB (T9) would be transmitted last. If it is desired to reverse the serialization order, such that the bit presented on TX4 is output first, this mode of operation may be selected via register 0x2E'h.

LOOP FILTER

The SER has an internal PLL which is used to generate the serialization clock from the parallel clock input. The loop filter for this PLL is external, and for optimum results in Serial Digital Interface applications, a capacitor and a resistor in series should be connected between pins 26 and 27. Recommended value for the capacitor is 0.1 μ F. Recommended value for the resistor is 500 Ω .

PLL FILTER / BYPASS

The SER has an external filter capacitor for the PLL. The recommended value for this capacitor is 22 μ F with a connection to the 3.3V rail.

DVB_ASI MODE

The SER has a special mode for DVB-ASI. In this mode, the input signal on TX4 \pm is treated as a data valid bit, if high, then the four bit nibbles from TX0-TX3 are taken to form an 8 bit word, which is then converted to a 10 bit code via an internal 8b10b encoder and this 10 bit word is serialized and driven on the output. The nibble taken in on the rising edge of the clock is the most significant nibble and the nibble taken in on the falling edge is the least significant nibble. If TX4 \pm is low, then the input on TX0-TX3 are ignored and the 10b idle character is inserted in the output stream. The Idle character can be reprogrammed to be any 10 bit code desired via registers 0x11'h and 0x12'h.

SDI OUTPUT INTERFACING

The serial outputs provide low-skew complimentary or differential signals. The output buffer is a current mode design, with a high impedance output. To drive a 75 Ω transmission line connect a 75 Ω resistor from each of the output pins to 2.5V. This resistor has two functions – it converts the current output to a voltage, which is used to drive the cable, and it acts as the back termination resistor for the transmission line. The resistor should be placed as close to the output pin as is

practicable. The output driver automatically adjusts its slew rate depending on the input data rate so that it will be in compliance with SMPTE 259M, SMPTE292M or SMPTE 424M as appropriate. In addition to output amplitude and rise/fall time specifications, the SMPTE specs require that SDI outputs meet an Output Return Loss (ORL) specification. There are parasitic capacitances that will be present both at the output pin of the device and on the application printed circuit board. To optimize the return loss implement a series network comprised of a parallel inductor and resistor. The actual values for these components will vary from application to application, but the typical interface circuit shows values that would be a good starting point. Figure 5 shows an equivalent output circuit for the LMH0340 / LMH0040 / LMH0070. The collectors present a high impedance current source. The external 75Ω resistors will provide the back termination resistance as well as converting the current to a voltage – with the addition of the termination resistance at the load, there will be an overall output resistance of 37.5Ω, which in conjunction with the 24-mA current source will develop the 800mV swings called for in the standard.

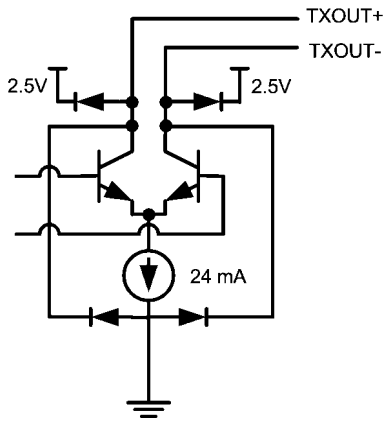

30017007

FIGURE 5. Simplified SDI Output Circuit

Care must be taken in the layout of the output circuitry to meet SMPTE return loss specifications as any parasitic impedances or transmission line discontinuities will result in reflections which will adversely affect the output return loss. For more details on how to get good output return loss, please refer to the application note “Successful design with the FPGA-Attach SER/DES”.

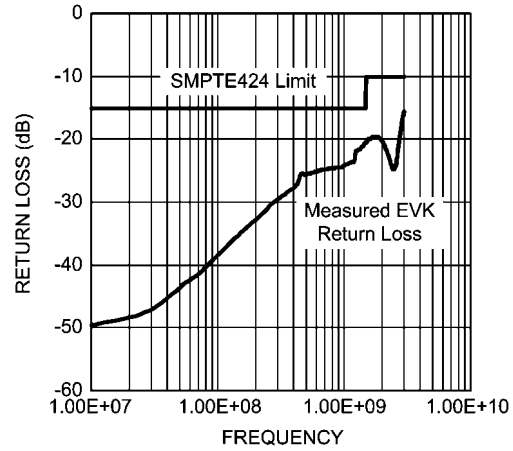

30017011

FIGURE 6. SDI Output Return Loss (EVK Example)

The amplitude of the output is guaranteed to be compliant with SMPTE specifications if the specified value of R_{SET} resistor is used, however if the designer wishes to change the output amplitude, there are two methods by which this can be done. By changing the value of resistor connected to the R_{SET} pin, the output amplitude will be adjusted.

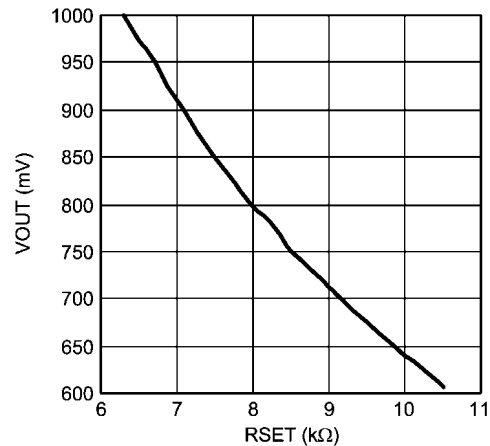

30017012

FIGURE 7. Output Voltage vs. R_{SET}

CML Output Interfacing

The LMH0050 does not include the internal SMPTE cable driver, as its outputs are CML, include internal 50 Ω pull up resistors, and are intended to drive 100 Ω transmission lines. The LMH0050 outputs may either be connected to a differential transmission medium such as twisted pair cable, or used to drive an external cable driver.

Power Down Mode

If the device is not to be used, some power can be saved by writing a '0x40h' to register 0x26'h, and a 0x10'h to register 0x01'h. The write to register 0x26'h will disable the input buffers of the device, and the write to register 0x01'h will power down the output buffer. In this mode, the device power dissipation can be expected to be reduced by approximately 30%. There are portions of the circuit which will automatically power down if there is no clock present on the TXCLK input, so this method can be used to further reduce the power.

SMBus INTERFACE

The configuration bus conforms to the System Management Bus (SMBus) 2.0 specification. SMBus 2.0 includes multiple options. The optional ARP (Address Resolution Protocol) feature is not supported. The I/O rail is 3.3V only and is not 5V tolerant. The use of the SMB_CS signal is recommended for applications with multi-drop applications (multiple devices to a host).

The SMBus is a two wire interface designed for the communication between various system component chips, additional signals maybe required for chip select function depending upon application. By accessing the control functions of the circuit via the SMBus, signal count is kept to a minimum while allowing a maximum amount of versatility. The SMBus has three pins to control it: an SMBus CS pin which enables the SMBus interface for the device, a Clock and a Data line. In applications where there might be several SER devices, the SDA and SCK pins can be bussed together and the individual devices to be communicated with may be selected via their respective SMB_CS pin. The SCK and SDA are both open drain and are pulled high by external pullup resistors. The SER has several internal configuration registers which may be accessed via the SMBus. These registers are listed in *SER Register Detail Table*.

TRANSFER OF DATA TO THE DEVICE VIA THE SMBus

During normal operation the data on SDA must be stable during the time when SCK is high.

START / STOP / IDLE CONDITIONS

There are three unique states for the SMBus:

- START** A HIGH-to-LOW transition on SDA while SCK is High indicates a message START condition
- STOP** A LOW-to-HIGH transition on SDA while SCK is High indicates a message STOP condition.
- IDLE** If SCK and SDA are both High for a time exceeding t_{BUF} from the last detected STOP condition or if they are high for a total exceeding the maximum specification for t_{HIGH} then the bus will transfer to the IDLE state.

SMBus TRANSACTIONS

A transaction begins with the host placing the SER SMBus into the START condition. Then a byte (8 bits) is transferred, MSB first, followed by a ninth ACK bit. ACK bits are '0' to signify an ACK, or '1' to signify NACK. After this the host holds the SCK line Low, and waits for the receiver to raise the SDA line as an ACKnowledge that the byte has been received.

REGISTER WRITE

To write a data value to a register in the SER, the host writes three bytes to the SER. The first byte is the device address—the device address is a 7 bit value, and if writing to the SER the last bit (LSB) is set to '0' to signify that the operation is a write. The second byte written is the register address, and the third byte written is the data to be written into the addressed register. If additional data writes are performed, the register address is automatically incremented. At the end of the write cycle the host places the bus in the STOP state.

REGISTER READ

To read the data value from a register, first the host writes the device address with the LSB set to a '0' denoting a write, and then the register address is written to the device. The host then reasserts the START condition, and writes the device address once again, but this time with the LSB set to a '1' denoting a read, and following this the SER will drive the SDA line with the data from the addressed register. The host indicates that it has finished reading the data by asserting a '0' for the ACK bit. After reading the last byte, the host will assert a '1' for NACK to indicate to the SER that it does not require any more data.

Note that the SMBus pins are not 5V compliant and they must be driven by a 3.3V source.

SMBus CONFIGURATIONS

Many different configurations of the SMBus are possible and depend upon the specific requirements of the applications. Several possible applications are described.

CONFIGURATION 1

The SER SMB_CS may be tied High (always enabled) since it is the only device on the SMBus. See *Figure 8*.

CONFIGURATION 2

Since the multiple SER devices have the same address, the use of the individual SMB_CS signals is required. To communicate with a specific device, its SMB_CS is driven High to select the device. After the transaction is complete, its SMB_CS is driven Low to disable its SMB interface. Other devices on the bus may now be selected with their respective chip select signals and communicated with. See *Figure 9*.

CONFIGURATION 3

The addressing field is limited to 7-bits by the SMBus protocol. Thus it is possible that multiple devices may share the same 7-bit address. An optional feature in the SMBus 2.0 specification supports an Address Resolution Protocol (ARP). This optional feature is not supported by the LMH0340/0040/0070/0050 devices. Solutions for this include: the use of the independent SMB_CS signals, independent SMBus segments, or other means. See *Figure 10*.

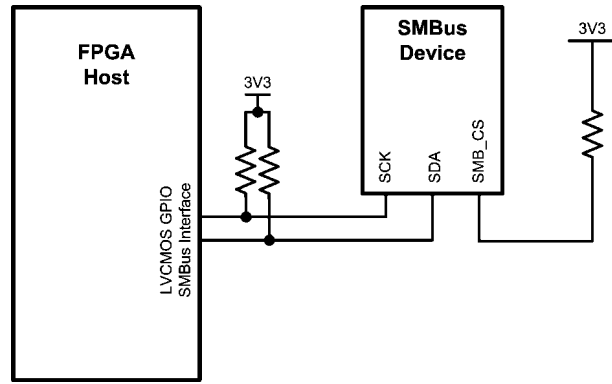

30017015

FIGURE 8. SMBus Configuration 1 — Host to single device

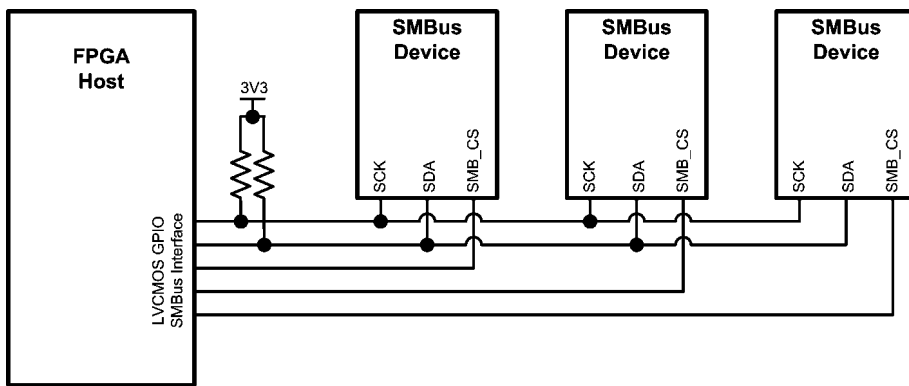

30017016

FIGURE 9. SMBus Configuration 2 — Host to multiple devices with SMB_CS signals

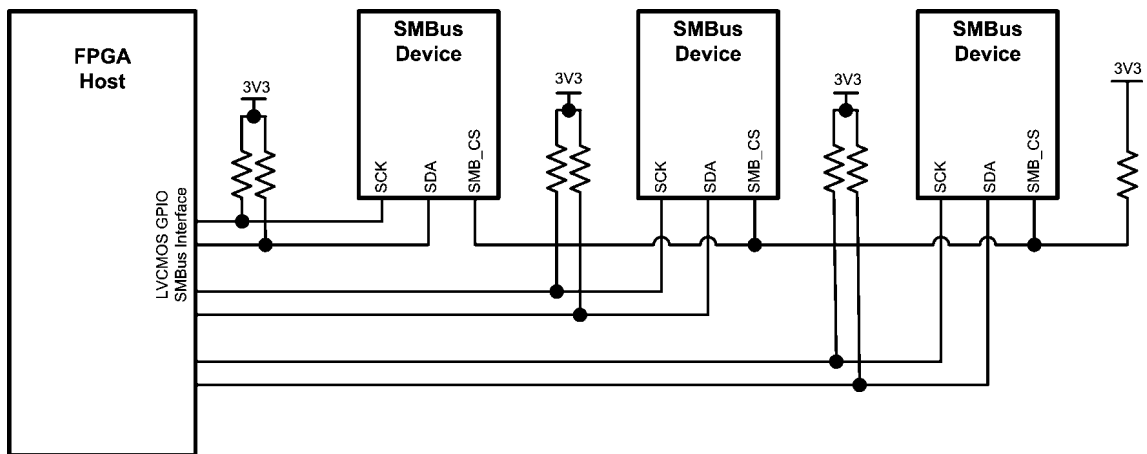

30017017

FIGURE 10. SMBus Configuration 3 — Host to multiple devices with multiple SMBus Interfaces

GENERAL PURPOSE I/O PINS GPIO[2:0]

The SER has three pins which can be configured to provide direct access to certain register values via a dedicated pin. For example if a particular application required fast action to the condition of the serializer losing its input clock, the TXCLK detect status bit could be routed directly to an external pin where it might generate an interrupt for the host processor. GPIO pins can be configured to be in TRI-STATE®(High Impedance) mode, the buffers can be disabled, and when used as inputs can be configured with a pullup resistor, a pulldown resistor or no input pin biasing at all. When the GPIO pins are being used as inputs, there is the ability to have an internal pullup or pull down resistor. This is selected via the GPIO Configuration registers.

Each of the GPIO pins has a register to control it. For each of these registers, the upper 4 bits are used to define what function is desired of the GPIO pin with options being slightly different for each of the three GPIO pins. The pins can be used to monitor the status of various internal states of the SER device, to serve as an input from some external stimulus, and for output to control some external function.

GPIO_0 FUNCTIONS

- Allow for the output of a signal programmed by the SMBus
- Allow the monitoring of an external signal via the SMBus
- Monitor Status of TXCLK signal
- Monitor Status of TXCLKDetect
- Monitor Power On Reset

GPIO_1 FUNCTIONS

- Monitor Power On Reset
- Allow for the output of a signal programmed by the SMBus
- Allow the monitoring of an external signal via the SMBus
- Monitor LOS for data bit 0
- Monitor LOS for data bit 1
- Monitor LOS for data bit 2
- Monitor LOS for data bit 3
- Monitor LOS for data bit 4

GPIO_2 FUNCTIONS

- Allow for the output of a signal programmed by the SMBus
- Allow the monitoring of an external signal via the SMBus
- Serializer Clock output

Bits 2 and 3 are used to determine the status of the internal pullup/pulldown resistors on the device—they are loaded according to the following truth table:

- 00: pullup and pulldown disabled
- 01: pulldown enabled
- 10: pullup enabled
- 11: Reserved

Bit 1 is used to enable or disable the input buffer. If the GPIO pin is to be used as an output pin, then this bit must be set to a '0' disabling the output.

The LSB is used to switch the output between normal output state and high impedance mode. If the GPIO is to be used as an input pin, this bit must be set to '0' placing the output in high Z mode.

As an example, if you wanted to use the GPIO₀ pin to reflect the status of the $\overline{\text{LOCK}}$ pin, you would load the appropriate register with the value 0001 0001b.

POTENTIAL APPLICATION FOR GPIO PINS

In addition to being useful debug tools while bringing a design up, there are other practical uses to which the GPIO pins can be put:

Sensing if a cable is connected to an output –

When connecting the BNC cable to the output, connect the shield of the connector to GND via a capacitor—making it an AC GND, but a DC open. Now connect that shield to one of the GPIO connections which you configure as an input with a pullup. With no cable on the BNC, the GPIO pin will see a high state, but once a terminated cable is connected, the shield will be brought down and you will read a low state.

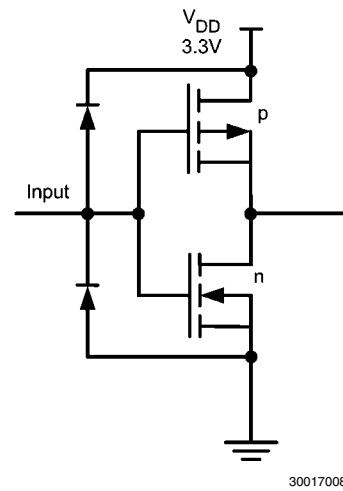

FIGURE 11. Simplified LVCMOS Input Circuit

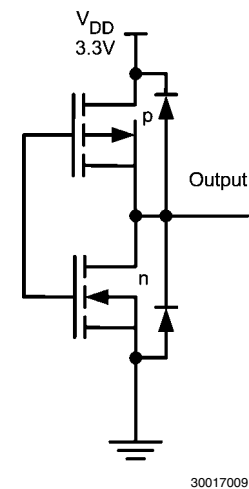

FIGURE 12. Simplified LVCMOS Output Circuit

Application Information

PCB RECOMMENDATIONS

The SMPTE Serial specifications have very stringent requirements for output return loss on drivers. The output return loss will be degraded by non-idealities in the connection between the SER (all variants with the exception of the LMH0050) and the output connector. All efforts should be taken to minimize the trace lengths for this area, and to assure that the characteristic impedance of this trace is 75Ω .

It is recommended that the PCB traces between the host FPGA and the SER be no longer than 10 inches (25cm) and that the traces be routed as differential pairs, with very tight matching of line lengths and coupling within a pair, as well as equal length traces for each of the six pairs. For additional information on layout and soldering of the LLP package, please refer to the applications note 'AN 1187'

PCB Design do's and don'ts:

- DO Whenever possible dedicate an entire layer to each power supply – this will reduce the inductance in the supply plane.
- DO use surface mount components whenever possible
- DO place bypass capacitors close to each power pin
- DON'T create ground loops – pay attention to the cutouts that are made in your power and ground planes to make sure that there are not opportunities for loops.
- DON'T allow discontinuities in the ground planes – return currents will follow the path of least resistance – for high frequency signals this will be the path of least inductance.
- DO place the SER outputs as close as possible to the edge of the PCB where it will connect to the outside world.
- DO make sure to match the trace lengths of all differential traces, both between the sides of an individual pair, and from pair to pair.
- DO remember that VIAs have significant inductance – when using a via to connect to a power supply or ground layer, two in parallel are better than one.
- DO connect the slug on the bottom of the package to a solid Ground connection. This contact is used for the major GND connection to the device as well as serving as a thermal via to keep the die at a low operating temperature.
- There is an application note available which discusses layout suggestions for the SER in greater detail.

TYPICAL SMPTE APPLICATIONS CIRCUIT

A typical application circuit for the LMH0340 is shown in *Figure 13*. Alternately this could also employ the LMH0040 or LMH0070 Serializers in lower data rate SMPTE applications. The TX interface between the host FPGA and the SER is composed of a 5-bit LVDS Data bus and its LVDS clock. This

is a point-to-point interface and the SER includes on-chip 100 terminations. Pairs should be of equal length to minimize any skew impact. The LVDS clock (TXCLK) uses both edges to transfer the data.

An SMBus is also connected from the host FPGA to the SER. If the SMBus is shared, a chip select signal is used to select the device being addressed. The SCK and SDA signals require a pull up resistor. The SMB_CS is driven by a GPO signal from the FPGA. Depending on the FPGA I/O it may also require a pull up unless it is a push / pull output.

Depending upon the application, several other GPIO signals maybe used. This includes the DVB_ASI and RESET input signals. If these pins are not used, then must be tied off to the desired state. The LOCK signal maybe used to monitor the SER. If it is unused, leave the pin as a NC (or route to a test point).

The SER includes a SMPTE compliant cable driver. While this is a differential driver, it is commonly used single-endedly to drive 75Ω coax cables. External 75Ω pull up resistors are used to the 2.5V rail. The active output(s) also includes a matching network to meet the required Output Return Loss SMPTE specification. While application specific, in general a series 75Ω resistor shunted by a 6.8 nH inductor will provide a starting value to design with. The signal is then AC coupled to the cable with a 4.7 μ F capacitor. If the complementary output is not used, simply terminate it after its AC coupling capacitor to ground. This output (even though its inverting) may still be used for a loop back or 1:2 function due to the nature of the NRZI coding that the SMPTE standards require. The output voltage amplitude of the cable driver is set by the R_{SET} resistor. For single-ended applications, an 8.06 k Ω resistor is connected between this pin and ground to set the swing to 800mV.

The PLL loop filter is external for the SER. A capacitor is connected in series to a resistor between the LF_CP and LF_REF pins. Typical values are 500 Ω and 0.1 μ F.

There are several configuration pins that requiring setting to the proper level. The RSVD_H pins should be pulled High to the 3.3V rail with a 5 k Ω resistor. Depending upon the application the DVB_ASI pin may be tied off or driven.

There are three supply connections (see By Pass discussion and also Pin Descriptions for recommendations). The two main supplies are the 3.3V rail and the 2.5V rail. There is also a 3.3V connection for the PLL circuitry.

There are multiple Ground connections for the device. The main ground connection for the SER is through the large center DAP pad. This **must** be connected to ground for proper device operation. In addition, multiple other inputs are required to be connected to ground as show in the figure and listed in the Pin Description table.

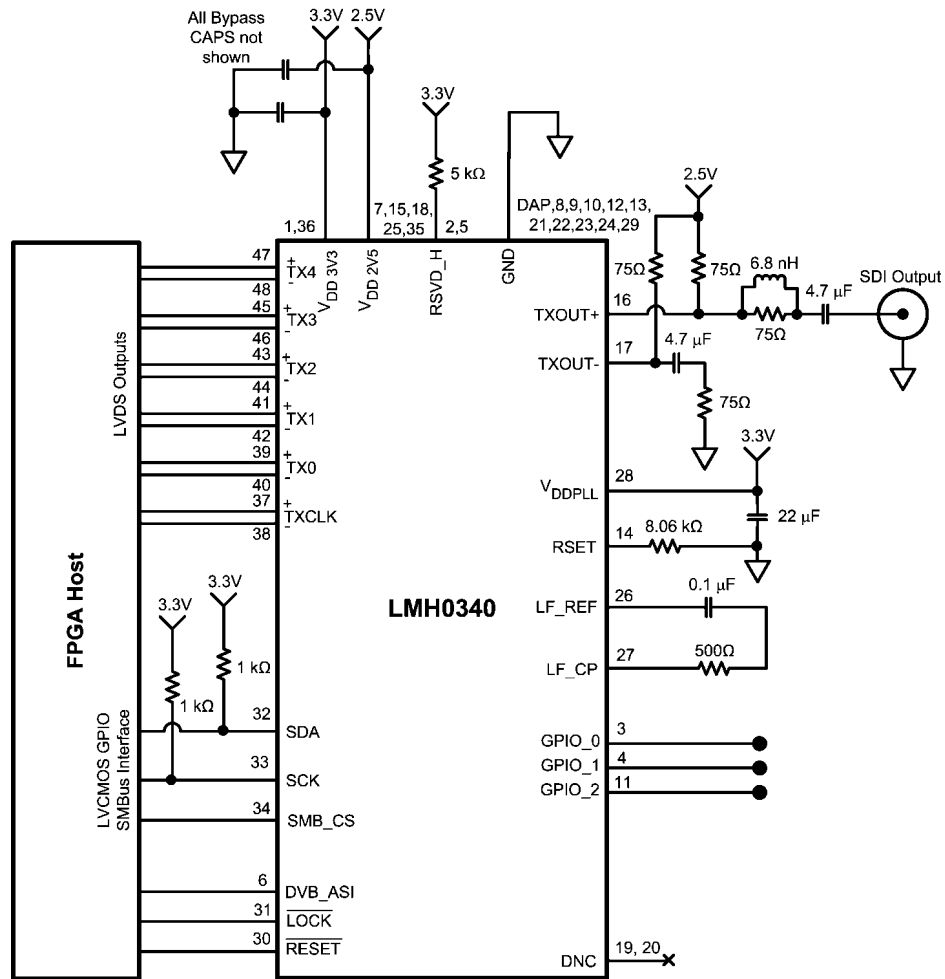

30017006

FIGURE 13. Typical SMPT Application Circuit

TYPICAL LMH0050 CML APPLICATIONS CIRCUIT

A typical application circuit for the LMH0050 is shown in Figure 14.

The TX interface between the host FPGA and the SER is composed of a 5-bit LVDS Data bus and its LVDS clock. This is a point-to-point interface and the SER includes on-chip 100 terminations. Pairs should be of equal length to minimize any skew impact. The LVDS clock (TXCLK) uses both edges to transfer the data.

An SMBus is also connected from the host FPGA to the SER. If the SMBus is shared, a chip select signal is used to select the device being addressed. The SCLK and SDA signals require a pull up resistor. The SMB_CS is driven by a GPO signal from the FPGA. Depending on the FPGA I/O it may also require a pull up unless it is a push / pull output.

Depending upon the application, several other GPIO signals maybe used. This includes the DVB_ASI and RESET input signals. If these pins are not used, then must be tied off to the desired state. The LOCK signal maybe used to monitor the SER. If it is unused, leave the pin as a NC (or route to a test point).

The LMH0050 SER includes a CML cable driver. This is a differential driver, and includes internal 50 Ω pull up resistors

to the 2.5V rail. The output voltage amplitude of the cable driver is set by the R_{SET} resistor. The R_{SET} resistor recommended value for the LMH0050 is 9.1KΩ. It is intended to drive 100 Ω differential pairs or twisted pair cables.

The PLL loop filter is external for the SER. A capacitor is connected in series to a resistor between the LF_CP and LF_REF pins. Typical values are 500 Ω and 0.1 μF.

There are several configuration pins that requiring setting to the proper level. The RSVD_H pins should be pulled High to the 3.3V rail with a 5 kΩ resistor. Depending upon the application the DVB_ASI pin may be tied off or driven.

There are three supply connections (see By Pass discussion and also Pin Descriptions for recommendations). The two main supplies are the 3.3V rail and the 2.5V rail. There is also a 3.3V connection for the PLL circuitry.

There are multiple Ground connections for the device. The main ground connection for the SER is through the large center DAP pad. This **must** be connected to ground for proper device operation. In addition, multiple other inputs are required to be connected to ground as show in the figure and listed in the Pin Description table.

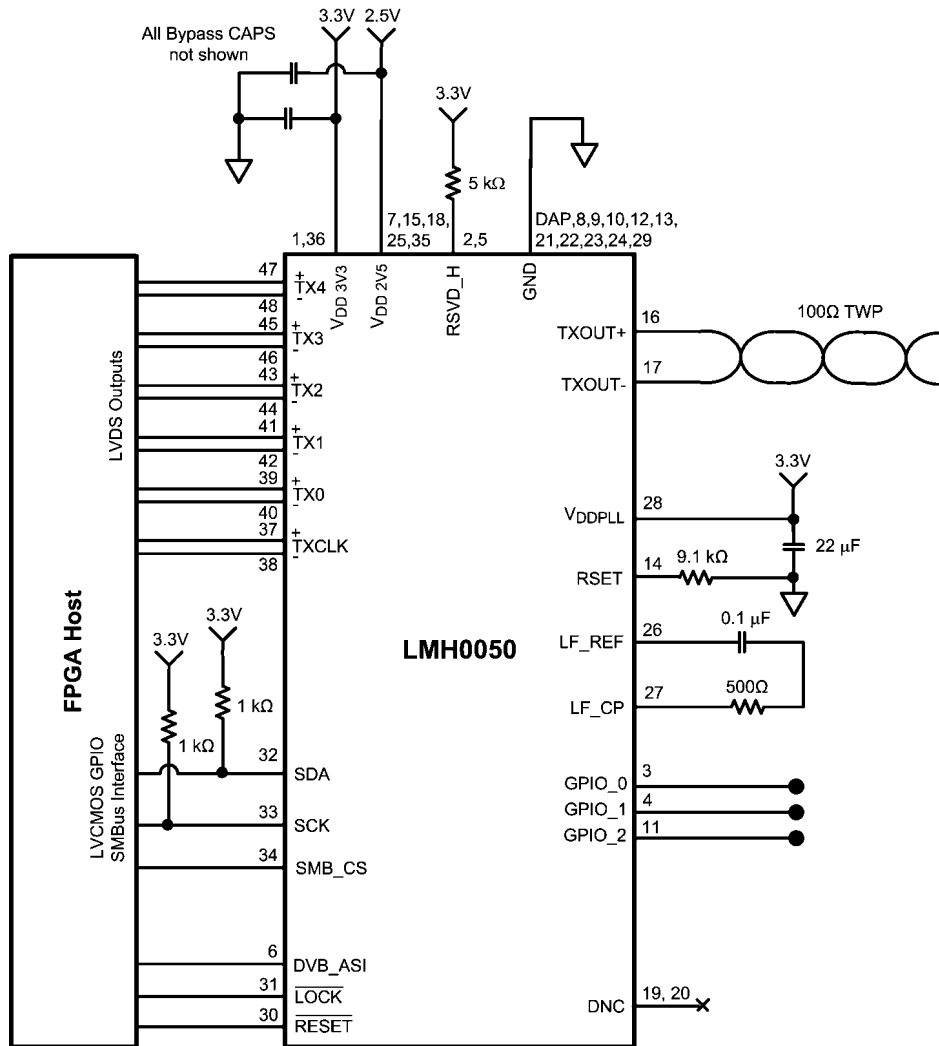

30017013

FIGURE 14. Typical LMH0050 CML Application Circuit

SERIAL JITTER OPTIMIZATION

The SER is capable of very low jitter operation, however it is dependent on the TXCLK provided by the host in order to operate, and depending on the quality of the TXCLK provided, the SER output jitter may not be as low as it could be.

The SER includes circuitry to filter out any TXCLK jitter at frequencies above 1MHz (see Figure 15), however, for frequencies below 100 kHz, any jitter that is in the TXCLK is passed directly through to the serialized output.

In most cases, passing the TXCLK through the FPGA will add high frequency noise to the signal, which will be filtered out by the SER, resulting in a clean output, however for better jitter performance, it is best to minimize the noise that is on the TXCLK that is provided to the SER. This can be done by careful routing of the CLK signals, both within the FPGA and on the board.

Very clean clocks can be derived from video reference signals through the use of the LMH1981 Sync Separator and the LMH1982 Clock Generator products from National Semiconductor. These products allow low jitter video frequency clocks to be generated either independently, or phase locked to a video reference signal.

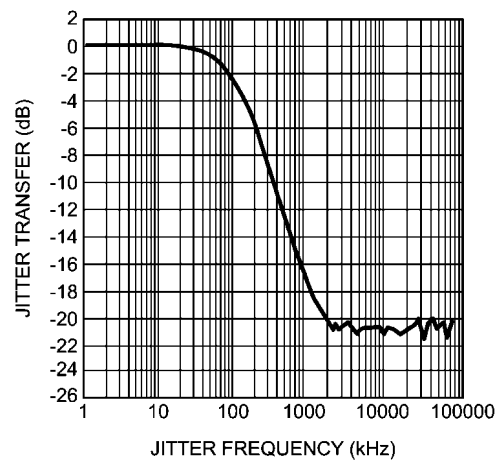

30017014

FIGURE 15. SER Jitter Transfer Function

Register Descriptions

The following table provides details on the device's configuration registers.

SER Register Detail Table

| ADD 'h | Name | Bits | Field | R/W | Default | Description |
|--------|-----------------------|--------------------------------------------------------------------------------------------------------------------------------------------------------------------------------------------------------------------------------------------------------------------------------------------------------------------------------------------------------------------------------------------------------------------------------------|------------------|-----|---------|---------------------------------------------------------------------------------------------------------------|
| 00 | device_identification | The seven MSBs of this register define the SMBus address for the device – the default value is 0x57'h, but this may be overwritten. The LSB of this register must always be '0' Note that since the address is shifted over by 1 bit, some systems may address the 57'h as AE'h. | | | | |
| | | 7:1 | device id | r/w | 57'h | SMBus device ID |
| | | 0 | Reserved | | 0'b | |
| 01 | reset | If a '1' is written to bit 0 (LSB) of this register the device will do a soft reset, restoring it's internal state to the same as at powerup except device_id register. Once the reset operation is complete, the value in this register is reset to '0' Bit 4 of this register has a default of 0, if a '1' is written to this location it will disable the analog output buffer of the device, allowing for some power savings. | | | | |
| | | 7:5 | Reserved | | | |
| | | 4 | Analog Dis | r/w | 0'b | Disables Analog |
| | | 3:1 | Reserved | | | |
| | | 0 | sw_rst | r/w | 0'b | software reset |
| 02 | GPIO_0 Configuration | This register configures GPIO_0. Note, if this pin is to be used as an input, then the output must be TRI-STATE (bit[0]='0') and if used as an output, then the input buffer must be disabled (bit[1]='0'). | | | | |
| | | 7:4 | GPIO_0_mode[3:0] | r/w | 0000'b | 0000: GPout register 0011: TXCLK LOS 0100: TXCLK Detect 0110: Power On Reset all others: reserved |
| | | 3:2 | GPIO_0_ren[1:0] | r/w | 01'b | 00: pullup and pulldown disabled 01: pulldown enabled 10: pullup enabled 11: Reserved |
| | | 1 | GPIO_0_sleepz | r/w | 0'b | 0: input buffer disabled 1: input buffer enabled |
| | | 0 | GPout0 enable | r/w | 1'b | 0: output TRI-STATE 1: output enabled |

| ADD 'h | Name | Bits | Field | R/W | Default | Description |
|--------|----------------------|-------------------------------------------------------------------------------------------------------------------------------------------------------------------------------------------------------------|------------------|-----|---------|------------------------------------------------------------------------------------------------------------------------------------------------------------------------------------------------------|
| 03 | GPIO_1 Configuration | This register configures GPIO_1. Note, if this pin is to be used as an input, then the output must be TRI-STATE (bit[0]='0') and if used as an output, then the input buffer must be disabled (bit[1]='0'). | | | | |
| | | 7:4 | GPIO_1_mode[3:0] | r/w | 0000'b | 0000: Power On Reset 0001: GPout register 0010: pll lock 0100: Data LOS [0] 0101: Data LOS [1] 0110: Data LOS [2] 0111: Data LOS [3] 1000: Data LOS [4] all others: reserved |
| | | 3:2 | GPIO_1_ren[1:0] | r/w | 01'b | 00: pullup and pulldown disabled 01: pulldown enabled 10: pullup enabled 11: Reserved |
| | | 1 | GPIO_1_sleepz | r/w | 0'b | 0: input buffer disabled 1: input buffer enabled |
| | | 0 | GPout1 enable | r/w | 1'b | 0: output in TRI-STATE mode 1: output enabled |
| 04 | GPIO_2 Configuration | This register configures GPIO_2. Note, if this pin is to be used as an input, then the output must be TRI-STATE (bit[0]='0') and if used as an output, then the input buffer must be disabled (bit[1]='0'). | | | | |
| | | 7:4 | GPIO_2_mode[3:0] | r/w | 0000'b | 0000: GPout register 0001: always on out 0010: parallel to serial clk out 0011: parallel clock output 0100: TXCLK Digital out all others: reserved |
| | | 3:2 | GPIO_2_ren[1:0] | r/w | 01'b | 00: pullup and pulldown disabled 01: pulldown enabled 10: pullup enabled 11: Reserved |
| | | 1 | GPIO_2_sleepz | r/w | 0'b | 0: input buffer disabled 1: input buffer enabled |
| | | 0 | GPout2 enable | r/w | 0'b | 0: output TRI-STATEd 1: output enabled |
| 05 | GP INPUT | If any of the GPIO pins are configured as inputs, then reading from this register provides the values on those input pins. | | | | |
| | | 7:3 | Reserved | | | |
| | | 2 | | r | | input data on GPIO_2 |
| | | 1 | | r | | input data on GPIO_1 |
| | | 0 | | r | | input data on GPIO_0 |
| 06 | GP OUTPUT | If the GPIO pins are configured as general purpose output pins, then writing to this register has the effect of transferring the bits in this register to the output buffers of the appropriate GPIO pins. | | | | |
| | | 7:3 | Reserved | | | |
| | | 2 | | r/w | 0'b | output data on GPIO_2 |
| | | 1 | | r/w | 0'b | output data on GPIO_1 |
| | | 0 | | r/w | 0'b | output data on GPIO_0 |
| 07-10 | Reserved | | | | | |

| ADD 'h | Name | Bits | Field | R/W | Default | Description |
|--------|-------------------------|-------------------------------------------------------------------------------------------------------------------------------------------------------------------------------------------------------------------------------------------------------------------------------------|---------------|-----|---------|---------------------------------------------------------------------------------------------------------------|
| 11 | DVB_ASI Idle_A | When in DVB-ASI mode, idle characters are inserted into the datastream when there is no valid data to transmit. The idle character default is K28.5 but if desired, that can be redefined via this register pair. | | | | |
| | | 7:0 | | r/w | BC'h | K28.5 Idle character used for DVB_ASI |
| 12 | DVB_ASI Idle_B | DVB-ASI mode, idle character LSBs | | | | |
| | | 7:2 | Reserved | | | |
| | | 1:0 | | r/w | 01'b | K28.5 Idle character used for DVB_ASI |
| 13-1C | Reserved | | | | | |
| 1D | Device Type | Reading from this register will return an 8 bit value which indicates which product from the SER family is being addressed | | | | |
| | | 7:0 | Device | r | | xx1xxx00 for the LMH0340 xx1xxx01 for the LMH0040 xx1xxx10 for the LMH0070 xx0xxx01 for the LMH0050 |
| 1E-20 | Reserved | | | | | |
| 21 | Mode | This register returns the mode that the device is operating in. | | | | |
| | | 7:2 | Reserved | | | |
| | | 1:0 | | r/w | | 11 = DVB ASI mode 01,10, 00 = SDI mode |
| 22 | DVB_ASI Override | In normal operation, the DVB_ASI mode is selected via the external pin. By setting the 0 bit in this register, the function of this pin is overridden, and the mode is set via register 21'h instead. After setting this bit, a channel reset must be executed via reg 0x26h, bit 7 | | | | |
| | | 7:1 | Reserved | | | |
| | | 0 | | r/w | 0'b | 1: contents of register 21h will override the DVB_ASI pin 0: Pin control |
| 23 | Reserved | | | | | |
| 24 | LVDS Clock Delay Bypass | This register selects of the TXCLK delay adjust is enabled or bypassed. | | | | |
| | | 7 | | r/w | 0'b | 1: Bypasses TXCLK delay 0: Delay Enabled |
| | | 6:0 | Reserved | | | |
| 25 | Reserved | | | | | |
| 26 | Powerdown | Individual bits from this register can power down different parts of the SER – to place the part into a low power standby mode, write a '0' to this register. | | | | |
| | | 7 | channel reset | r/w | 0'b | Used to reset the channel, needed when changing between DVB_ASI mode and normal operating mode via SMBus |
| | | 6:0 | Powerdown | r/w | 0x3Fh | for normal operation, write x011 1111b to this register. For low power mode write x100 0000b to the register. |

| ADD 'h | Name | Bits | Field | R/W | Default | Description |
|--------|-------------------|------------------------------------------------------------------------------------------------------------------------------------------------------------------------------------------------------------------------------------------------|----------------------|-----|---------|-------------------------------------------------------------------------------------------|
| 27 | Event Disable | The SER keeps counts of various types of events. These include FIFO over/underflows, and loss of the input signals or clocks. This register allows the user to mask these errors from being counted. | | | | |
| | | 7:5 | Reserved | | | |
| | | 4 | PLL_CLK_disable | r/w | 0'b | 1: Clock Error disabled 0: Clock Errors counted |
| | | 3 | fifo_error_disable | r/w | 0'b | 1: FIFO Errors ignored 0: FIFO Errors counted |
| | | 2 | TXCLK_detect_disable | r/w | 0'b | 1: TXCLK Detect Errors ignored 0: TXCLK Detect Errors counted |
| | | 1 | CLK_LOS_disable | r/w | 0'b | 1: CLK_LOS Errors ignored 0: CLK_LOS Errors counted |
| 28 | LVDS Operation | | | | | |
| | | 7:2 | Reserved | | | |
| | | 1 | LVDS Preset | r/w | 0'b | 1: 0: |
| | | 0 | LVDS Reset LOS | r/w | 0'b | 1: 0: |
| 29 | LOS Status | Reading the LOS status register will provide a byte which has six bits which represent the presence or absence of a signal at each of the LVDS inputs to the SER. | | | | |
| | | 7:6 | Reserved | | | |
| | | 5 | LOS_CLK | r | 0'b | 1: Clock present 0: No Clock present on TXCLK |
| 2A | Event Status | The event status register has two user readable bits which indicate if the device is locked, and if there is a signal present on the TXCLK input. | | | | |
| | | 7:4 | Reserved | | | |
| | | 3 | TXCLK_detect | r | 0'b | 1: TXCLK detected 0: TXCLK not detected |
| | | 2 | PLL_lock | r | 0'b | 1: PLL locked 0: PLL not locked |
| 1:0 | Reserved | | | | | |
| 2B-2D | Reserved | | | | | |
| 2E | Reverse Bit Order | This bit can be used to reverse the serialization order, however it will only work properly when the device is NOT in DVB_ASI mode | | | | |
| | | 7 | Reserved | | | |
| | | 6 | Reverse Bit Order | r/w | 0'b | 1: reverses serialization order 0: normal order |
| 5:0 | Reserved | | | | | |
| 2F | Reserved | | | | | |
| 30 | CLK_Delay | The three msbs from this register are used to insert a programmable delay into the TXCLK path, if the host FPGA does not provide adequate setup and hold times for the SER, this register can be used to shift the window in 125ps increments. | | | | |
| | | 7:5 | TCLK Delay | r/w | 011'b | 000'b is minimum delay setting, 111'b is maximum delay setting, each step is approx 125ps |
| | | 4:0 | Reserved | | | |

Connection Diagram

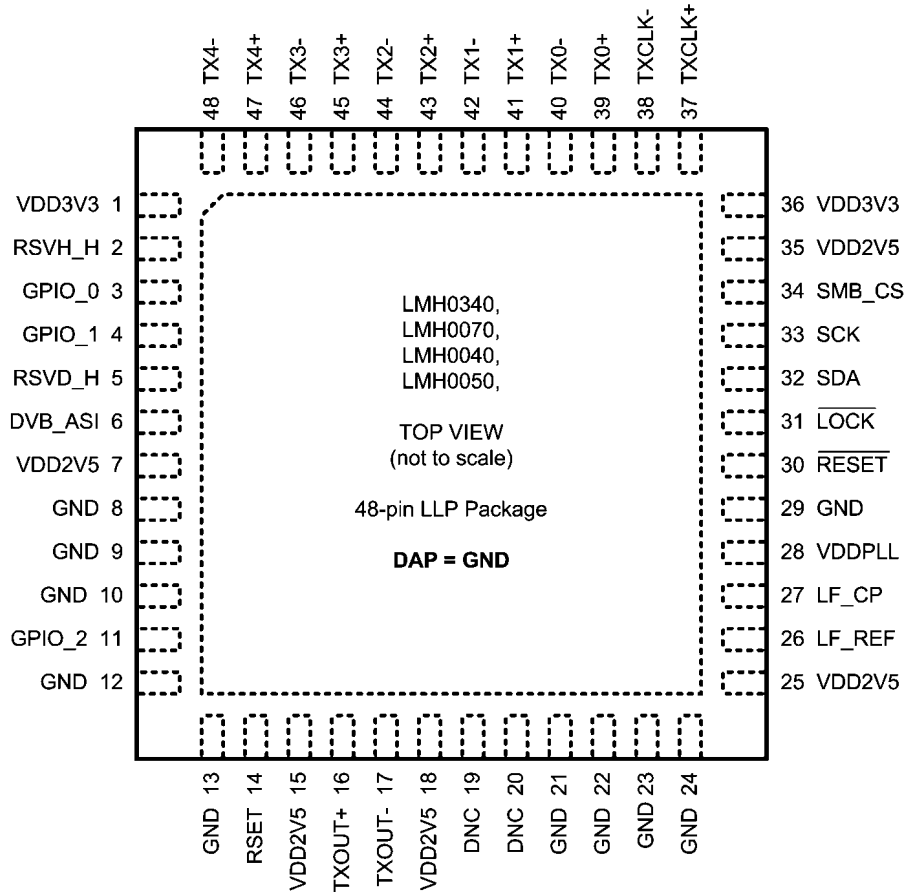

30017010

FIGURE 16. Connection Diagram for 48L LLP Package

Ordering Information

| NSID | Speed | Cable Driver | Units per T&R | Package |
|------------|--------------|--------------|---------------|---------|
| LMH0340SQ | 3G / HD / SD | SMPTE | 1,000 | SQA48A |
| LMH0340SQX | | | 2,500 | |
| LMH0340SQE | | | 250 | |
| LMH0040SQ | HD / SD | SMPTE | 1,000 | SQA48A |
| LMH0040SQX | | | 2,500 | |
| LMH0040SQE | | | 250 | |
| LMH0070SQ | SD | SMPTE | 1,000 | SQA48A |
| LMH0070SQX | | | 2,500 | |
| LMH0070SQE | | | 250 | |
| LMH0050SQ | HD / SD | CML | 1,000 | SQA48A |
| LMH0050SQX | | | 2,500 | |
| LMH0050SQE | | | 250 | |

Physical Dimensions inches (millimeters) unless otherwise noted

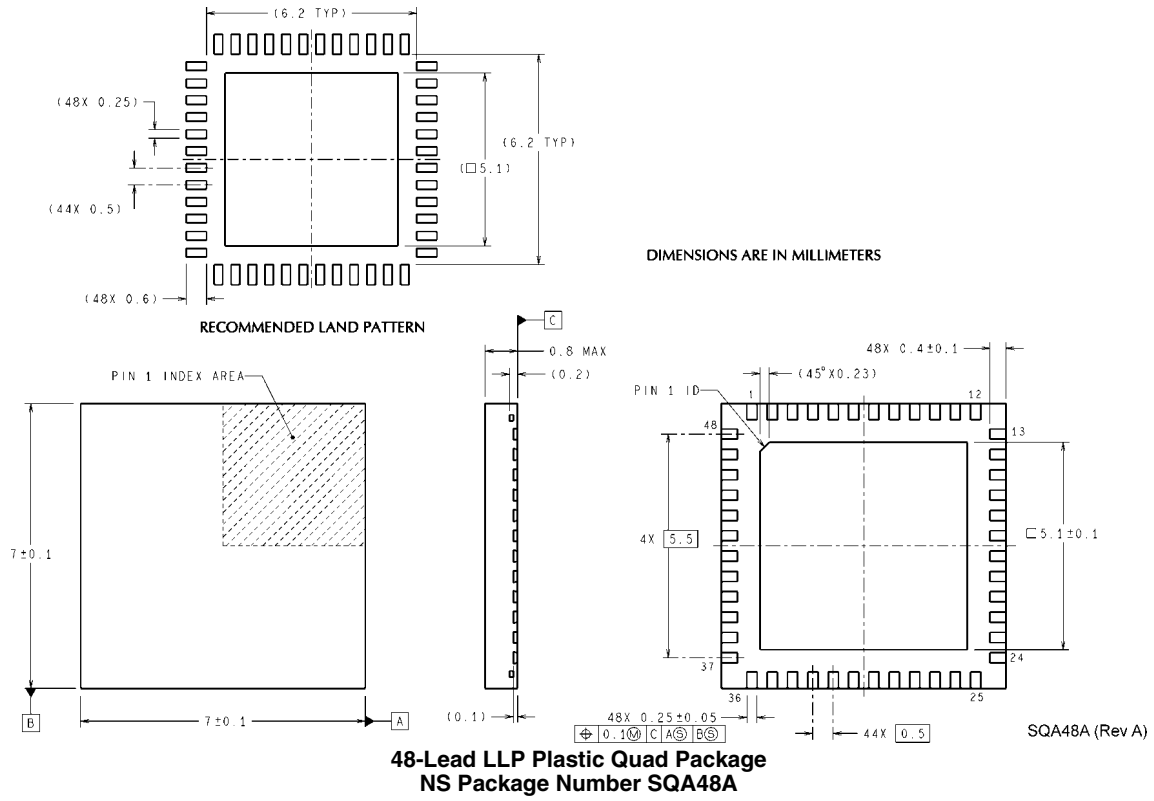

Notes

For more National Semiconductor product information and proven design tools, visit the following Web sites at:

| Products | | Design Support | |
|--------------------------------|--------------------------------------------------------------------------------|-------------------------|------------------------------------------------------------------------------------|
| Amplifiers | www.national.com/amplifiers | WEBENCH | www.national.com/webench |
| Audio | www.national.com/audio | Analog University | www.national.com/AU |
| Clock Conditioners | www.national.com/timing | App Notes | www.national.com/appnotes |
| Data Converters | www.national.com/adc | Distributors | www.national.com/contacts |
| Displays | www.national.com/displays | Green Compliance | www.national.com/quality/green |
| Ethernet | www.national.com/ethernet | Packaging | www.national.com/packaging |
| Interface | www.national.com/interface | Quality and Reliability | www.national.com/quality |
| LVDS | www.national.com/lvds | Reference Designs | www.national.com/refdesigns |
| Power Management | www.national.com/power | Feedback | www.national.com/feedback |
| Switching Regulators | www.national.com/switchers | | |
| LDOs | www.national.com/ldo | | |
| LED Lighting | www.national.com/led | | |
| PowerWise | www.national.com/powerwise | | |
| Serial Digital Interface (SDI) | www.national.com/sdi | | |
| Temperature Sensors | www.national.com/tempsensors | | |
| Wireless (PLL/VCO) | www.national.com/wireless | | |

THE CONTENTS OF THIS DOCUMENT ARE PROVIDED IN CONNECTION WITH NATIONAL SEMICONDUCTOR CORPORATION ("NATIONAL") PRODUCTS. NATIONAL MAKES NO REPRESENTATIONS OR WARRANTIES WITH RESPECT TO THE ACCURACY OR COMPLETENESS OF THE CONTENTS OF THIS PUBLICATION AND RESERVES THE RIGHT TO MAKE CHANGES TO SPECIFICATIONS AND PRODUCT DESCRIPTIONS AT ANY TIME WITHOUT NOTICE. NO LICENSE, WHETHER EXPRESS, IMPLIED, ARISING BY ESTOPPEL OR OTHERWISE, TO ANY INTELLECTUAL PROPERTY RIGHTS IS GRANTED BY THIS DOCUMENT.

TESTING AND OTHER QUALITY CONTROLS ARE USED TO THE EXTENT NATIONAL DEEMS NECESSARY TO SUPPORT NATIONAL'S PRODUCT WARRANTY. EXCEPT WHERE MANDATED BY GOVERNMENT REQUIREMENTS, TESTING OF ALL PARAMETERS OF EACH PRODUCT IS NOT NECESSARILY PERFORMED. NATIONAL ASSUMES NO LIABILITY FOR APPLICATIONS ASSISTANCE OR BUYER PRODUCT DESIGN. BUYERS ARE RESPONSIBLE FOR THEIR PRODUCTS AND APPLICATIONS USING NATIONAL COMPONENTS. PRIOR TO USING OR DISTRIBUTING ANY PRODUCTS THAT INCLUDE NATIONAL COMPONENTS, BUYERS SHOULD PROVIDE ADEQUATE DESIGN, TESTING AND OPERATING SAFEGUARDS.

EXCEPT AS PROVIDED IN NATIONAL'S TERMS AND CONDITIONS OF SALE FOR SUCH PRODUCTS, NATIONAL ASSUMES NO LIABILITY WHATSOEVER, AND NATIONAL DISCLAIMS ANY EXPRESS OR IMPLIED WARRANTY RELATING TO THE SALE AND/OR USE OF NATIONAL PRODUCTS INCLUDING LIABILITY OR WARRANTIES RELATING TO FITNESS FOR A PARTICULAR PURPOSE, MERCHANTABILITY, OR INFRINGEMENT OF ANY PATENT, COPYRIGHT OR OTHER INTELLECTUAL PROPERTY RIGHT.

LIFE SUPPORT POLICY

NATIONAL'S PRODUCTS ARE NOT AUTHORIZED FOR USE AS CRITICAL COMPONENTS IN LIFE SUPPORT DEVICES OR SYSTEMS WITHOUT THE EXPRESS PRIOR WRITTEN APPROVAL OF THE CHIEF EXECUTIVE OFFICER AND GENERAL COUNSEL OF NATIONAL SEMICONDUCTOR CORPORATION. As used herein:

Life support devices or systems are devices which (a) are intended for surgical implant into the body, or (b) support or sustain life and whose failure to perform when properly used in accordance with instructions for use provided in the labeling can be reasonably expected to result in a significant injury to the user. A critical component is any component in a life support device or system whose failure to perform can be reasonably expected to cause the failure of the life support device or system or to affect its safety or effectiveness.

National Semiconductor and the National Semiconductor logo are registered trademarks of National Semiconductor Corporation. All other brand or product names may be trademarks or registered trademarks of their respective holders.

Copyright© 2008 National Semiconductor Corporation

For the most current product information visit us at www.national.com



National Semiconductor Americas Technical Support Center
 Email: new.feedback@nsc.com
 Tel: 1-800-272-9959

National Semiconductor Europe Technical Support Center
 Email: europe.support@nsc.com
 German Tel: +49 (0) 180 5010 771
 English Tel: +44 (0) 870 850 4288

National Semiconductor Asia Pacific Technical Support Center
 Email: ap.support@nsc.com

National Semiconductor Japan Technical Support Center
 Email: jpn.feedback@nsc.com