



MEMS digital output motion sensor ultra low-power high performance 3-axes “nano” accelerometer

Features

- Wide supply voltage, 1.71 V to 3.6 V
- Independent IOs supply (1.8 V) and supply voltage compatible
- Ultra low-power mode consumption down to 2 μ A
- $\pm 2g/\pm 4g/\pm 8g/\pm 16g$ dynamically selectable full-scale
- I²C/SPI digital output interface
- 16 bit data output
- 2 independent programmable interrupt generators for free-fall and motion detection
- 6D/4D orientation detection
- Free-fall detection
- Motion detection
- Embedded temperature sensor
- Embedded self-test
- Embedded 96 levels of 16 bit data output FIFO
- 10000 g high shock survivability
- ECOPACK[®] RoHS and “Green” compliant

Applications

- Motion activated functions
- Free-fall detection
- Click/double click recognition
- Intelligent power saving for handheld devices
- Pedometer
- Display orientation
- Gaming and virtual reality input devices
- Impact recognition and logging
- Vibration monitoring and compensation

Description

The LIS3DH is an ultra low-power high performance three axes linear accelerometer

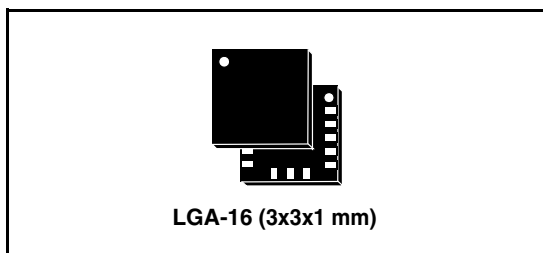

belonging to the “nano” family, with digital I²C/SPI serial interface standard output. The device features ultra low-power operational modes that allow advanced power saving and smart embedded functions.

The LIS3DH has dynamically user selectable full scales of $\pm 2g/\pm 4g/\pm 8g/\pm 16g$ and it is capable of measuring accelerations with output data rates from 1 Hz to 5 kHz. The self-test capability allows the user to check the functioning of the sensor in the final application. The device may be configured to generate interrupt signals by two independent inertial wake-up/free-fall events as well as by the position of the device itself. Thresholds and timing of interrupt generators are programmable by the end user on the fly. The LIS3DH has an integrated 32-level first in, first out (FIFO) buffer allowing the user to store data for host processor intervention reduction. The LIS3DH is available in small thin plastic land grid array package (LGA) and it is guaranteed to operate over an extended temperature range from -40 °C to +85 °C.

Table 1. Device summary

Order codes	Temp. range [°C]	Package	Packaging
LIS3DH	-40 to +85	LGA-16	Tray
LIS3DHTR	-40 to +85	LGA-16	Tape and reel

Contents

1	Block diagram and pin description	8
1.1	Block diagram	8
1.2	Pin description	8
2	Mechanical and electrical specifications	10
2.1	Mechanical characteristics	10
2.2	Temperature sensor characteristics	11
2.3	Electrical characteristics	11
2.4	Communication interface characteristics	12
2.4.1	SPI - serial peripheral interface	12
2.4.2	I2C - Inter IC control interface	13
2.5	Absolute maximum ratings	14
3	Terminology and functionality	15
3.1	Terminology	15
3.1.1	Sensitivity	15
3.1.2	Zero-g level	15
3.2	Functionality	15
3.2.1	Normal mode, low power mode	15
3.2.2	Self-test	16
3.2.3	6D / 4D orientation detection	16
3.3	Sensing element	16
3.4	IC interface	16
3.5	Factory calibration	17
3.6	FIFO	17
3.7	Auxiliary ADC	17
4	Application hints	18
4.1	Soldering information	18
5	Digital main blocks	19
5.1	FIFO	19
5.1.1	Bypass mode	19

5.1.2	FIFO mode	19
5.1.3	Stream mode	19
5.1.4	Stream-to-FIFO mode	19
5.1.5	Retrieve data from FIFO	19
6	Digital interfaces	20
6.1	I2C serial interface	20
6.1.1	I2C operation	21
6.2	SPI bus interface	22
6.2.1	SPI read	23
6.2.2	SPI write	24
6.2.3	SPI read in 3-wires mode	25
7	Register mapping	26
8	Registers description	28
8.1	STATUS_AUX (07h)	28
8.2	OUT_1_L (08h), OUT_1_H (09h)	28
8.3	OUT_2_L (0Ah), OUT_2_H (0Bh)	28
8.4	OUT_3_L (0Ch), OUT_3_H (0Dh)	28
8.5	INT_COUNTER (0Eh)	29
8.6	WHO_AM_I (0Fh)	29
8.7	TEMP_CFG_REG (1Fh)	29
8.8	CTRL_REG1 (20h)	29
8.9	CTRL_REG2 (21h)	30
8.10	CTRL_REG3 (22h)	31
8.11	CTRL_REG4 (23h)	31
8.12	CTRL_REG5 (24h)	32
8.13	CTRL_REG6 (25h)	32
8.14	REFERENCE/DATACAPTURE (26h)	32
8.15	STATUS_REG (27h)	33
8.16	OUT_X_L (28h), OUT_X_H (29h)	33
8.17	OUT_Y_L (2Ah), OUT_Y_H (2Bh)	33
8.18	OUT_Z_L (2Ch), OUT_Z_H (2Dh)	33
8.19	FIFO_CTRL_REG (2Eh)	34

8.20	FIFO_SRC_REG (2Fh)	34
8.21	INT1_CFG (30h)	34
8.22	INT1_SRC (31h)	35
8.23	INT1_THS (32h)	36
8.24	INT1_DURATION (33h)	36
8.25	CLICK_CFG (38h)	36
8.26	CLICK_SRC (39h)	37
8.27	CLICK_THS (3Ah)	38
8.28	TIME_LIMIT (3Bh)	38
8.29	TIME_LATENCY (3Ch)	38
8.30	TIME WINDOW(3Dh)	38
9	Package information	39
10	Revision history	41

List of figures

Figure 1.	Block diagram	8
Figure 2.	Pin connection	8
Figure 3.	SPI slave timing diagram	12
Figure 4.	I2C Slave timing diagram	13
Figure 5.	LIS3DH electrical connection	18
Figure 6.	Read and write protocol	22
Figure 7.	SPI read protocol	23
Figure 8.	Multiple bytes SPI read protocol (2 bytes example)	24
Figure 9.	SPI write protocol	24
Figure 10.	Multiple bytes SPI write protocol (2 bytes example)	24
Figure 11.	SPI read protocol in 3-wires mode	25
Figure 12.	LGA-16: Mechanical data and package dimensions	40

List of tables

Table 1.	Device summary	1
Table 2.	Pin description	9
Table 3.	Mechanical characteristics	10
Table 4.	Temperature sensor characteristics	11
Table 5.	Electrical characteristics	11
Table 6.	SPI slave timing values.	12
Table 7.	I2C slave timing values.	13
Table 8.	Absolute maximum ratings	14
Table 9.	Operating mode selection	15
Table 10.	Serial interface pin description	20
Table 11.	Serial interface pin description	20
Table 12.	SAD+Read/Write patterns	21
Table 13.	Transfer when master is writing one byte to slave	21
Table 14.	Transfer when master is writing multiple bytes to slave:	21
Table 15.	Transfer when master is receiving (reading) one byte of data from slave:	22
Table 16.	Transfer when master is receiving (reading) multiple bytes of data from slave	22
Table 17.	Register address map.	26
Table 18.	STATUS_REG_AUX register	28
Table 19.	STATUS_REG_AUX description	28
Table 20.	INT_COUNTER register	29
Table 21.	WHO_AM_I register	29
Table 22.	TEMP_CFG_REG register	29
Table 23.	TEMP_CFG_REG description	29
Table 24.	CTRL_REG1 register	29
Table 25.	CTRL_REG1 description	29
Table 26.	Data rate configuration	30
Table 27.	CTRL_REG2 register	30
Table 28.	CTRL_REG2 description	30
Table 29.	High pass filter mode configuration	31
Table 30.	CTRL_REG3 register	31
Table 31.	CTRL_REG3 description	31
Table 32.	CTRL_REG4 register	31
Table 33.	CTRL_REG4 description	31
Table 34.	Self test mode configuration	32
Table 35.	CTRL_REG5 register	32
Table 36.	CTRL_REG5 description	32
Table 37.	CTRL_REG6 register	32
Table 38.	REFERENCE register.	32
Table 39.	REFERENCE register description	33
Table 40.	STATUS register.	33
Table 41.	STATUS register description	33
Table 42.	REFERENCE register.	34
Table 43.	REFERENCE register description	34
Table 44.	FIFO mode configuration	34
Table 45.	FIFO_SRC register.	34
Table 46.	INT1_CFG register	34
Table 47.	INT1_CFG description	34
Table 48.	Interrupt mode	35

Table 49.	INT1_SRC register	35
Table 50.	INT1_SRC description	35
Table 51.	INT1_THS register	36
Table 52.	INT1_THS description	36
Table 53.	INT1_DURATION register	36
Table 54.	INT1_DURATION description	36
Table 55.	CLICK_CFG register	36
Table 56.	CLICK_CFG description	37
Table 57.	CLICK_SRC register	37
Table 58.	CLICK_SRC description	37
Table 59.	CLICK_THS register	38
Table 60.	CLICK_SRC description	38
Table 61.	TIME_LIMIT register	38
Table 62.	TIME_LIMIT description	38
Table 63.	TIME_LATENCY register	38
Table 64.	TIME_LATENCY description	38
Table 65.	TIME_WINDOW register	38
Table 66.	TIME_WINDOW description	38
Table 67.	LGA-16: Mechanical data	40
Table 68.	Document revision history	41

1 Block diagram and pin description

1.1 Block diagram

Figure 1. Block diagram

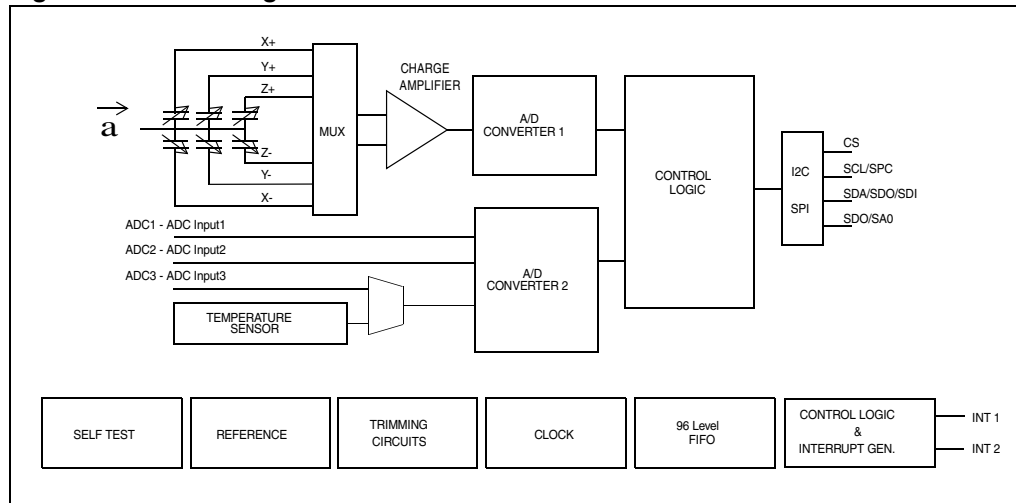

1.2 Pin description

Figure 2. Pin connection

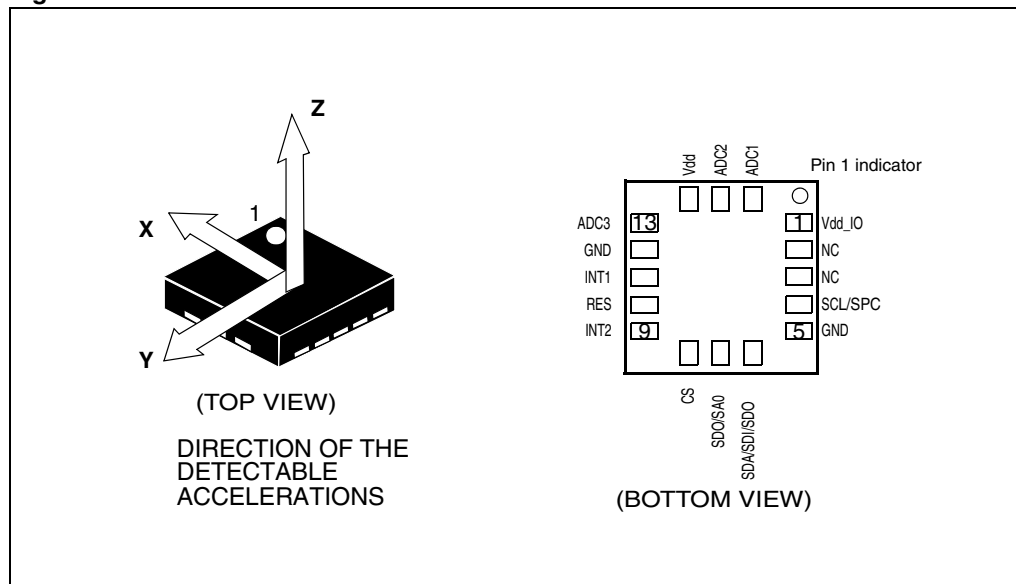

Table 2. Pin description

Pin#	Name	Function
1	Vdd_IO	Power supply for I/O pins
2	NC	Not connected
3	NC	Not connected
4	SCL SPC	I ² C serial clock (SCL) SPI serial port clock (SPC)
5	GND	0V supply
6	SDA SDI SDO	I ² C serial data (SDA) SPI serial data input (SDI) 3-wire interface serial data output (SDO)
7	SDO SA0	SPI serial data output (SDO) I ² C less significant bit of the device address (SA0)
8	CS	SPI enable I ² C/SPI mode selection (1: I ² C mode; 0: SPI enabled)
9	INT2	Inertial interrupt 2
10	RES	Connect to GND
11	INT1	Inertial interrupt 1
12	GND	0 V supply
13	ADC3	Analog to digital converter input 3
14	Vdd	Power supply
15	ADC2	Analog to digital converter input 2
16	ADC1	Analog to digital converter input 1

2 Mechanical and electrical specifications

2.1 Mechanical characteristics

Vdd = 2.5 V, T = 25 °C unless otherwise noted ^(a)

Table 3. Mechanical characteristics

Symbol	Parameter	Test conditions	Min.	Typ. ⁽¹⁾	Max.	Unit
FS	Measurement range ⁽²⁾	FS bit set to 00		±2.0		
		FS bit set to 01		±4.0		
		FS bit set to 10		±8.0		
		FS bit set to 11		±16.0		<i>g</i>
So	Sensitivity	FS bit set to 00		1		mg/digit
		FS bit set to 01		2		mg/digit
		FS bit set to 10		4		mg/digit
		FS bit set to 11		12		mg/digit
TCSO	Sensitivity change vs temperature	FS bit set to 00		0.01		%/°C
TyOff	Typical zero- <i>g</i> level offset accuracy ^{(3),(4)}	FS bit set to 00		±40		mg
TCOff	Zero- <i>g</i> level change vs temperature	Max delta from 25 °C		±0.5		mg/°C
An	Acceleration noise density	FS bit set to 00, Normal Mode (Table 9), ODR = 100Hz		220		ug/sqrt(Hz)
Vst	Self-test output change ^{(5),(6),(7)}	FS bit set to 00 X axis		276		LSb
		FS bit set to 00 Y axis		276		LSb
		FS bit set to 00 Z axis		984		LSb
Top	Operating temperature range		-40		+85	°C

1. Typical specifications are not guaranteed.
2. Verified by wafer level test and measurement of initial offset and sensitivity.
3. Typical zero-*g* level offset value after MSL3 preconditioning.
4. Offset can be eliminated by enabling the built-in high pass filter.
5. The sign of "Self-test output change" is defined by CTRL_REG4 STsign bit, for all axes.
6. Self-test output changes with the power supply. "Self-test output change" is defined as $OUTPUT[LSb]_{(CTRL_REG4\ ST\ bit=1)} - OUTPUT[LSb]_{(CTRL_REG4\ ST\ bit=0)}$. 1LSb=1mg, ±2 *g* Full-scale.
7. Output data reach 99% of final value after 1 ms when enabling self-test mode, due to device filtering.

a. The product is factory calibrated at 2.5 V. The operational power supply range is from 1.71V to 3.6 V.

2.2 Temperature sensor characteristics

Vdd = 2.5 V, T = 25 °C unless otherwise noted ^(b)

Table 4. Temperature sensor characteristics

Symbol	Parameter	Test condition	Min.	Typ. ⁽¹⁾	Max.	Unit
TSDr	Temperature sensor output change vs temperature			1		digit/°C ⁽²⁾
TODR	Temperature refresh rate			ODR		Hz
Top	Operating temperature range		-40		+85	°C

1. Typical specifications are not guaranteed.
2. 8-bit resolution.

2.3 Electrical characteristics

Vdd = 2.5 V, T = 25 °C unless otherwise noted ^(c)

Table 5. Electrical characteristics

Symbol	Parameter	Test conditions	Min.	Typ. ⁽¹⁾	Max.	Unit
Vdd	Supply voltage		1.71	2.5	3.6	V
Vdd_IO	I/O pins supply voltage ⁽²⁾		1.71		Vdd+0.1	V
Idd	Current consumption in normal mode	50 Hz ODR		11		µA
Idd	Current consumption in normal mode	1 Hz ODR		2		µA
IddLP	Current consumption in low-power mode	50 Hz ODR		6		µA
IddPdn	Current consumption in power-down mode			0.5		µA
VIH	Digital high level input voltage		0.8*Vdd_IO			V
VIL	Digital low level input voltage				0.2*Vdd_IO	V
VOH	High level output voltage		0.9*Vdd_IO			V
VOL	Low level output voltage				0.1*Vdd_IO	V
BW	System bandwidth ⁽³⁾			ODR/2		Hz
Ton	Turn-on time ⁽⁴⁾	ODR = 100 Hz		1		ms
Top	Operating temperature range		-40		+85	°C

1. Typical specification are not guaranteed.
2. It is possible to remove Vdd maintaining Vdd_IO without blocking the communication busses, in this condition the measurement chain is powered off.
3. Referred to [Table 25](#) for the ODR value and configuration.
4. Time to obtain valid data after exiting power-down mode.

b. The product is factory calibrated at 2.5 V.

c. The product is factory calibrated at 2.5 V. The operational power supply range is from 1.71 V to 3.6 V.

2.4 Communication interface characteristics

2.4.1 SPI - serial peripheral interface

Subject to general operating conditions for Vdd and Top.

Table 6. SPI slave timing values

Symbol	Parameter	Value ⁽¹⁾		Unit
		Min	Max	
tc(SPC)	SPI clock cycle	100		ns
fc(SPC)	SPI clock frequency		10	MHz
tsu(CS)	CS setup time	6		ns
th(CS)	CS hold time	8		
tsu(SI)	SDI input setup time	5		
th(SI)	SDI input hold time	15		
tv(SO)	SDO valid output time		50	
th(SO)	SDO output hold time	9		
tdis(SO)	SDO output disable time		50	

Figure 3. SPI slave timing diagram

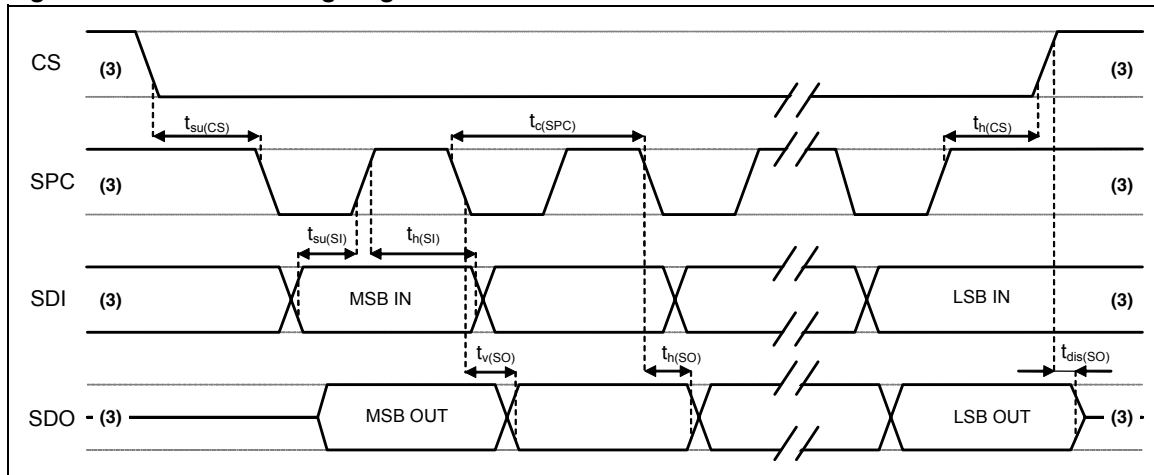

- Note:
- 1 Values are guaranteed at 10 MHz clock frequency for SPI with both 4 and 3 wires, based on characterization results, not tested in production.
 - 2 Measurement points are done at $0.2 \cdot V_{dd_IO}$ and $0.8 \cdot V_{dd_IO}$, for both Input and output port.
 - 3 When no communication is on-going, data on CS, SPC, SDI and SDO are driven by internal pull-up resistors.

2.4.2 I²C - Inter IC control interface

Subject to general operating conditions for V_{dd} and top.

Table 7. I²C slave timing values

Symbol	Parameter	I ² C standard mode ⁽¹⁾		I ² C fast mode ⁽¹⁾		Unit
		Min	Max	Min	Max	
f _(SCL)	SCL clock frequency	0	100	0	400	kHz
t _{w(SCLL)}	SCL clock low time	4.7		1.3		
t _{w(SCLH)}	SCL clock high time	4.0		0.6		μs
t _{su(SDA)}	SDA setup time	250		100		ns
t _{h(SDA)}	SDA data hold time	0.01	3.45	0.01	0.9	μs
t _{r(SDA)} t _{r(SCL)}	SDA and SCL rise time		1000	20 + 0.1C _b ⁽²⁾	300	ns
t _{f(SDA)} t _{f(SCL)}	SDA and SCL fall time		300	20 + 0.1C _b ⁽²⁾	300	
t _{h(ST)}	START condition hold time	4		0.6		μs
t _{su(SR)}	Repeated START condition setup time	4.7		0.6		
t _{su(SP)}	STOP condition setup time	4		0.6		
t _{w(SP:SR)}	Bus free time between STOP and START condition	4.7		1.3		

1. Data based on standard I²C protocol requirement, not tested in production.

2. C_b = total capacitance of one bus line, in pF.

Figure 4. I²C Slave timing diagram

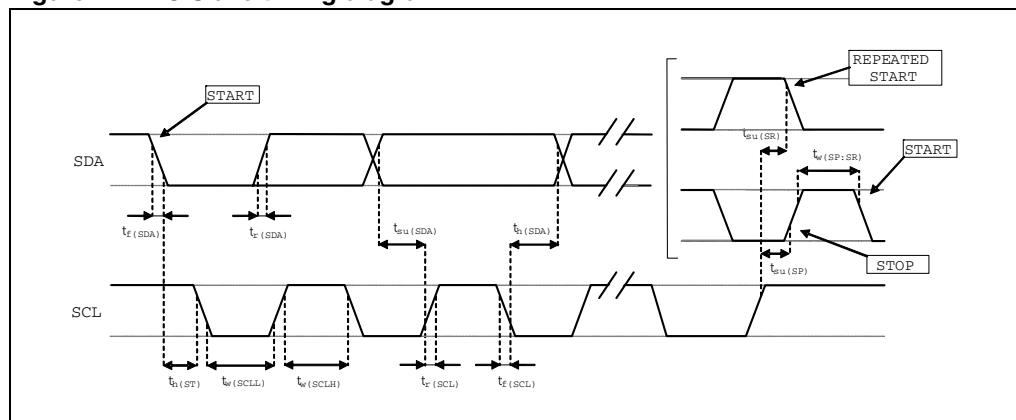

Note: Measurement points are done at 0.2·V_{dd_IO} and 0.8·V_{dd_IO}, for both port.

2.5 Absolute maximum ratings

Stresses above those listed as “absolute maximum ratings” may cause permanent damage to the device. This is a stress rating only and functional operation of the device under these conditions is not implied. Exposure to maximum rating conditions for extended periods may affect device reliability.

Table 8. Absolute maximum ratings

Symbol	Ratings	Maximum value	Unit
V _{DD}	Supply voltage	-0.3 to 4.8	V
V _{DD_IO}	I/O pins Supply voltage	-0.3 to 4.8	V
V _{IN}	Input voltage on any control pin (CS, SCL/SPC, SDA/SDI/SDO, SDO/SA0)	-0.3 to V _{DD_IO} +0.3	V
A _{POW}	Acceleration (any axis, powered, V _{DD} = 2.5 V)	3000 for 0.5 ms	g
		10000 for 0.1 ms	g
A _{UNP}	Acceleration (any axis, unpowered)	3000 for 0.5 ms	g
		10000 for 0.1 ms	g
T _{OP}	Operating temperature range	-40 to +85	°C
T _{STG}	Storage temperature range	-40 to +125	°C
ESD	Electrostatic discharge protection	2 (HBM)	kV

Note: Supply voltage on any pin should never exceed 4.8 V



This is a mechanical shock sensitive device, improper handling can cause permanent damages to the part.



This is an ESD sensitive device, improper handling can cause permanent damages to the part.

3 Terminology and functionality

3.1 Terminology

3.1.1 Sensitivity

Sensitivity describes the gain of the sensor and can be determined e.g. by applying 1 *g* acceleration to it. As the sensor can measure DC accelerations this can be done easily by pointing the axis of interest towards the center of the earth, noting the output value, rotating the sensor by 180 degrees (pointing to the sky) and noting the output value again. By doing so, ± 1 *g* acceleration is applied to the sensor. Subtracting the larger output value from the smaller one, and dividing the result by 2, leads to the actual sensitivity of the sensor. This value changes very little over temperature and also time. The sensitivity tolerance describes the range of Sensitivities of a large population of sensors.

3.1.2 Zero-*g* level

Zero-*g* level offset (TyOff) describes the deviation of an actual output signal from the ideal output signal if no acceleration is present. A sensor in a steady state on a horizontal surface measure 0 *g* in X axis and 0 *g* in Y axis whereas the Z axis measure 1 *g*. The output is ideally in the middle of the dynamic range of the sensor (content of OUT registers 00h, data expressed as 2's complement number). A deviation from ideal value in this case is called Zero-*g* offset. Offset is to some extent a result of stress to MEMS sensor and therefore the offset can slightly change after mounting the sensor onto a printed circuit board or exposing it to extensive mechanical stress. Offset changes little over temperature, see "Zero-*g* level change vs. temperature". The Zero-*g* level tolerance (TyOff) describes the standard deviation of the range of Zero-*g* levels of a population of sensors.

3.2 Functionality

3.2.1 Normal mode, low power mode

LIS3DH provides two different operating modes respectively reported as *normal mode* and *low power mode*. While normal mode guarantees high resolution, low power mode reduces further the current consumption.

The table below reported summarizes how to select the operating mode.

Table 9. Operating mode selection

CTRL_REG1[3] (LPen bit)	CTRL_REG4[3] (HR bit)	Operating mode
1	0	Low power mode
0	1	Normal mode

3.2.2 Self-test

Self-test allows to check the sensor functionality without moving it. The self-test function is off when the self-test bit (ST) is programmed to '0'. When the self-test bit is programmed to '1' an actuation force is applied to the sensor, simulating a definite input acceleration. In this case the sensor outputs exhibit a change in their DC levels which are related to the selected full scale through the device sensitivity. When self-test is activated, the device output level is given by the algebraic sum of the signals produced by the acceleration acting on the sensor and by the electrostatic test-force. If the output signals change within the amplitude specified inside [Table 3](#), then the sensor is working properly and the parameters of the interface chip are within the defined specifications.

3.2.3 6D / 4D orientation detection

The LIS3DH include 6D / 4D orientation detection.

6D / 4D orientation recognition: In this configuration the interrupt is generated when the device is stable in a known direction. In 4D configuration Z axis position detection is disable.

3.3 Sensing element

A proprietary process is used to create a surface micro-machined accelerometer. The technology allows carrying out suspended silicon structures which are attached to the substrate in a few points called anchors and are free to move in the direction of the sensed acceleration. To be compatible with the traditional packaging techniques a cap is placed on top of the sensing element to avoid blocking the moving parts during the moulding phase of the plastic encapsulation.

When an acceleration is applied to the sensor the proof mass displaces from its nominal position, causing an imbalance in the capacitive half-bridge. This imbalance is measured using charge integration in response to a voltage pulse applied to the capacitor.

At steady state the nominal value of the capacitors are few pF and when an acceleration is applied the maximum variation of the capacitive load is in the fF range.

3.4 IC interface

The complete measurement chain is composed by a low-noise capacitive amplifier which converts the capacitive unbalancing of the MEMS sensor into an analog voltage that is finally available to the user by an analog-to-digital converter.

The acceleration data may be accessed through an I²C/SPI interface thus making the device particularly suitable for direct interfacing with a microcontroller.

The LIS3DH features a Data-Ready signal (RDY) which indicates when a new set of measured acceleration data is available thus simplifying data synchronization in the digital system that uses the device.

The LIS3DH may also be configured to generate an inertial Wake-Up and Free-Fall interrupt signal accordingly to a programmed acceleration event along the enabled axes. Both Free-Fall and Wake-Up can be available simultaneously on two different pins.

3.5 **Factory calibration**

The IC interface is factory calibrated for sensitivity (S_0) and Zero- g level ($TyOff$).

The trimming values are stored inside the device in a non volatile memory. Any time the device is turned on, the trimming parameters are downloaded into the registers to be used during the active operation. This allows to use the device without further calibration.

3.6 **FIFO**

The LIS3DH contains a 10 bit, 32-level FIFO. Buffered output allows 4 operation modes: FIFO, stream, trigger and FIFO ByPass. Where FIFO bypass mode is activated FIFO is not operating and remains empty. In FIFO mode, data from acceleration detection on x, y, and z-axes measurements are stored in FIFO.

3.7 **Auxiliary ADC**

The LIS3DH contains an auxiliary 10 bit ADC with 3 separate dedicated inputs.

4 Application hints

Figure 5. LIS3DH electrical connection

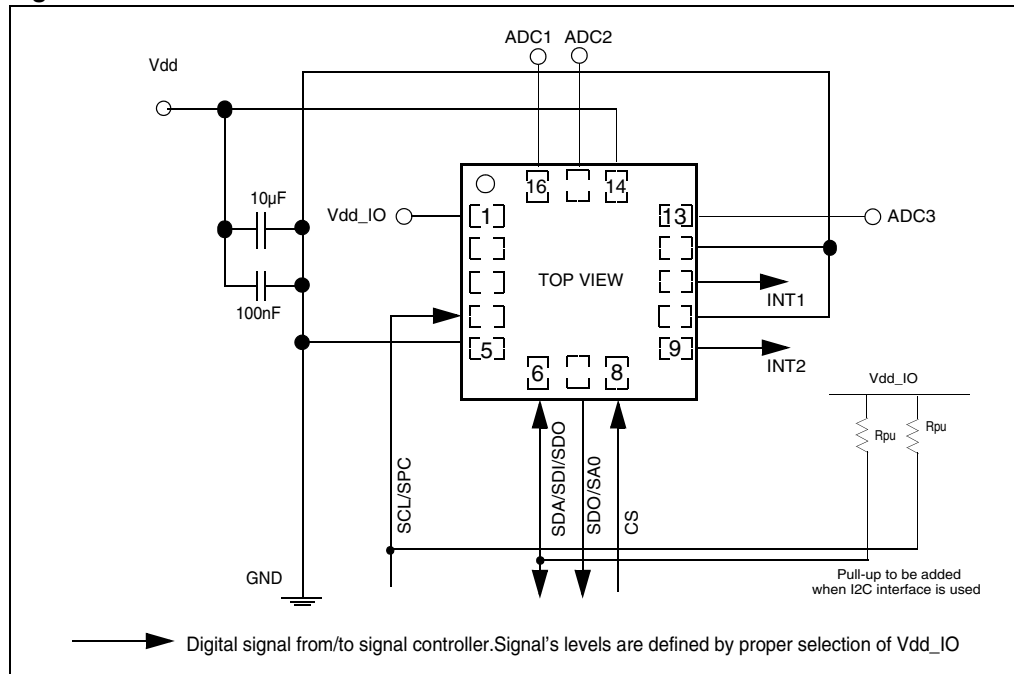

The device core is supplied through Vdd line while the I/O pads are supplied through Vdd_IO line. Power supply decoupling capacitors (100 nF ceramic, 10 µF aluminum) should be placed as near as possible to the pin 14 of the device (common design practice).

All the voltage and ground supplies must be present at the same time to have proper behavior of the IC (refer to [Figure 5](#)). It is possible to remove Vdd maintaining Vdd_IO without blocking the communication bus, in this condition the measurement chain is powered off.

The functionality of the device and the measured acceleration data is selectable and accessible through the I²C or SPI interfaces. When using the I²C, CS must be tied high.

The ADC1, ADC2 & ADC3 if not used can be left floating or keep connected to Vdd or GND.

The functions, the threshold and the timing of the two interrupt pins (INT1 and INT2) can be completely programmed by the user through the I²C/SPI interface.

4.1 Soldering information

The LGA package is compliant with the ECOPACK[®], RoHS and “Green” standard. It is qualified for soldering heat resistance according to JEDEC J-STD-020.

Leave “Pin 1 Indicator” unconnected during soldering.

Land pattern and soldering recommendations are available at www.st.com.

5 Digital main blocks

5.1 FIFO

LIS3DH embeds a 32-slot of 10bit data FIFO for each of the three output channels, X, Y and Z. This allows a consistent power saving for the system, since the host processor does not need to continuously poll data from the sensor, but it can wakeup only when needed and burst the significant data out from the FIFO. This buffer can work accordingly to four different modes: Bypass mode, FIFO mode, Stream mode and Stream-to-FIFO mode. Each mode is selected by the FIFO_MODE bits into the FIFO_CTRL_REG (2E). Programmable Watermark level, FIFO_empty or FIFO_Full events can be enabled to generate dedicated interrupts on INT1/2 pin (configuration through FIFO_CFG_REG).

5.1.1 Bypass mode

In Bypass mode, the FIFO is not operational and for this reason it remains empty. As described in the next figure, for each channel only the first address is used. The remaining FIFO slots are empty.

5.1.2 FIFO mode

In FIFO mode, data from X, Y and Z channels are stored into the FIFO. A watermark interrupt can be enabled (FIFO_WTMK_EN bit into FIFO_CTRL_REG in order to be raised when the FIFO is filled to the level specified into the FIFO_WTMK_LEVEL bits of FIFO_CTRL_REG. The FIFO continues filling until it is full (32 slots of 10data for X, Y and Z). When full, the FIFO stops collecting data from the input channels.

5.1.3 Stream mode

In the stream mode, data from X, Y and Z measurement are stored into the FIFO. A watermark interrupt can be enabled and set as in the FIFO mode. The FIFO continues filling until it's full (32 slots of 10data for X, Y and Z). When full, the FIFO discards the older data as the new arrive.

5.1.4 Stream-to-FIFO mode

In Stream-to_FIFO mode, data from X, Y and Z measurement are stored into the FIFO. A watermark interrupt can be enabled (FIFO_WTMK_EN bit into FIFO_CTRL_REG) in order to be raised when the FIFO is filled to the level specified into the FIFO_WTMK_LEVEL bits of FIFO_CTRL_REG. The FIFO continues filling until it's full (32 slots of 10 data for X, Y and Z). When full, the FIFO discards the older data as the new arrive. Once trigger event occurs, the FIFO starts operating in FIFO mode.

5.1.5 Retrieve data from FIFO

FIFO data is read through OUT_X (Addr reg 28h,29h), OUT_Y (Addr reg 2Ah,2Bh) and OUT_Z (Addr reg 2Ch,2Dh). When the FIFO is in stream, Trigger or FIFO mode, a read operation to the OUT_X, OUT_Y or OUT_Z registers provides the data stored into the FIFO. Each time data is read from the FIFO, the oldest X, Y and Z data are placed into the OUT_X, OUT_Y and OUT_Z registers and both single read and read_burst operations can be used.

6 Digital interfaces

The registers embedded inside the LIS3DH may be accessed through both the I²C and SPI serial interfaces. The latter may be SW configured to operate either in 3-wire or 4-wire interface mode.

The serial interfaces are mapped onto the same pads. To select/exploit the I²C interface, CS line must be tied high (i.e. connected to Vdd_IO).

Table 10. Serial interface pin description

Pin name	Pin description
CS	SPI enable I ² C/SPI mode selection (1: I ² C mode; 0: SPI enabled)
SCL	I ² C serial clock (SCL)
SPC	SPI serial port clock (SPC)
SDA	I ² C serial data (SDA)
SDI	SPI serial data input (SDI)
SDO	3-wire interface serial data output (SDO)
SA0	I ² C less significant bit of the device address (SA0)
SDO	SPI serial data output (SDO)

6.1 I²C serial interface

The LIS3DH I²C is a bus slave. The I²C is employed to write data into registers whose content can also be read back.

The relevant I²C terminology is given in the table below.

Table 11. Serial interface pin description

Term	Description
Transmitter	The device which sends data to the bus
Receiver	The device which receives data from the bus
Master	The device which initiates a transfer, generates clock signals and terminates a transfer
Slave	The device addressed by the master

There are two signals associated with the I²C bus: the serial clock line (SCL) and the Serial Data line (SDA). The latter is a bidirectional line used for sending and receiving the data to/from the interface. Both the lines must be connected to Vdd_IO through external pull-up resistor. When the bus is free both the lines are high.

The I²C interface is compliant with fast mode (400 kHz) I²C standards as well as with the normal mode.

6.1.1 I²C operation

The transaction on the bus is started through a START (ST) signal. A START condition is defined as a HIGH to LOW transition on the data line while the SCL line is held HIGH. After this has been transmitted by the Master, the bus is considered busy. The next byte of data transmitted after the start condition contains the address of the slave in the first 7 bits and the eighth bit tells whether the Master is receiving data from the slave or transmitting data to the slave. When an address is sent, each device in the system compares the first seven bits after a start condition with its address. If they match, the device considers itself addressed by the Master.

The Slave Address (SAD) associated to the LIS3DH is 001100xb. **SDO/SA0** pad can be used to modify less significant bit of the device address. If SA0 pad is connected to voltage supply, LSb is '1' (address 0011001b) else if SA0 pad is connected to ground, LSb value is '0' (address 0011000b). This solution permits to connect and address two different accelerometers to the same I²C lines.

Data transfer with acknowledge is mandatory. The transmitter must release the SDA line during the acknowledge pulse. The receiver must then pull the data line LOW so that it remains stable low during the HIGH period of the acknowledge clock pulse. A receiver which has been addressed is obliged to generate an acknowledge after each byte of data received.

The I²C embedded inside the LIS3DH behaves like a slave device and the following protocol must be adhered to. After the start condition (ST) a slave address is sent, once a slave acknowledge (SAK) has been returned, a 8-bit sub-address (SUB) is transmitted: the 7 LSb represent the actual register address while the MSB enables address auto increment. If the MSb of the SUB field is '1', the SUB (register address) is automatically increased to allow multiple data read/write.

The slave address is completed with a Read/Write bit. If the bit was '1' (Read), a repeated START (SR) condition must be issued after the two sub-address bytes; if the bit is '0' (Write) the Master transmit to the slave with direction unchanged. [Table 12](#) explains how the SAD+Read/Write bit pattern is composed, listing all the possible configurations.

Table 12. SAD+Read/Write patterns

Command	SAD[6:1]	SAD[0] = SA0	R/W	SAD+R/W
Read	001100	0	1	00110001 (31h)
Write	001100	0	0	00110000 (30h)
Read	001100	1	1	00110011 (33h)
Write	001100	1	0	00110010 (32h)

Table 13. Transfer when master is writing one byte to slave

Master	ST	SAD + W		SUB		DATA		SP
Slave			SAK		SAK		SAK	

Table 14. Transfer when master is writing multiple bytes to slave:

Master	ST	SAD + W		SUB		DATA		DATA		SP
Slave			SAK		SAK		SAK		SAK	

Table 15. Transfer when master is receiving (reading) one byte of data from slave:

Master	ST	SAD + W		SUB		SR	SAD + R			NMAK	SP
Slave			SAK		SAK			SAK	DATA		

Table 16. Transfer when master is receiving (reading) multiple bytes of data from slave

Master	ST	SAD+W		SUB		SR	SAD+R			MAK		MAK		NMAK	SP
Slave			SAK		SAK			SAK	DATA		DATA		DATA		

Data are transmitted in byte format (DATA). Each data transfer contains 8 bits. The number of bytes transferred per transfer is unlimited. Data is transferred with the Most Significant bit (MSb) first. If a receiver can't receive another complete byte of data until it has performed some other function, it can hold the clock line, SCL LOW to force the transmitter into a wait state. Data transfer only continues when the receiver is ready for another byte and releases the data line. If a slave receiver doesn't acknowledge the slave address (i.e. it is not able to receive because it is performing some real time function) the data line must be left HIGH by the slave. The Master can then abort the transfer. A LOW to HIGH transition on the SDA line while the SCL line is HIGH is defined as a STOP condition. Each data transfer must be terminated by the generation of a STOP (SP) condition.

In order to read multiple bytes, it is necessary to assert the most significant bit of the sub-address field. In other words, SUB(7) must be equal to 1 while SUB(6-0) represents the address of first register to be read.

In the presented communication format MAK is Master acknowledge and NMAK is No Master Acknowledge.

6.2 SPI bus interface

The LIS3DH SPI is a bus slave. The SPI allows to write and read the registers of the device.

The Serial Interface interacts with the outside world with 4 wires: **CS**, **SPC**, **SDI** and **SDO**.

Figure 6. Read and write protocol

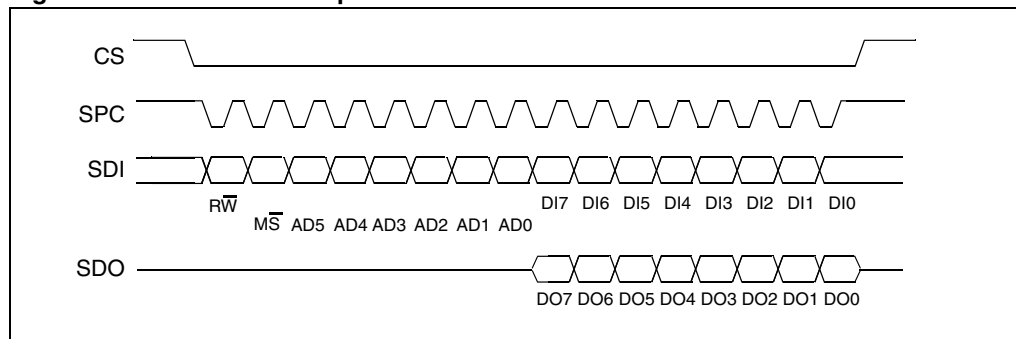

CS is the serial port enable and it is controlled by the SPI master. It goes low at the start of the transmission and goes back high at the end. **SPC** is the serial port clock and it is controlled by the SPI master. It is stopped high when **CS** is high (no transmission). **SDI** and

SDO are respectively the serial port data input and output. Those lines are driven at the falling edge of **SPC** and should be captured at the rising edge of **SPC**.

Both the read register and write register commands are completed in 16 clock pulses or in multiple of 8 in case of multiple bytes read/write. Bit duration is the time between two falling edges of **SPC**. The first bit (bit 0) starts at the first falling edge of **SPC** after the falling edge of **CS** while the last bit (bit 15, bit 23, ...) starts at the last falling edge of **SPC** just before the rising edge of **CS**.

bit 0: \overline{RW} bit. When 0, the data $DI(7:0)$ is written into the device. When 1, the data $DO(7:0)$ from the device is read. In latter case, the chip drives **SDO** at the start of bit 8.

bit 1: \overline{MS} bit. When 0, the address remains unchanged in multiple read/write commands. When 1, the address is auto incremented in multiple read/write commands.

bit 2-7: address $AD(5:0)$. This is the address field of the indexed register.

bit 8-15: data $DI(7:0)$ (write mode). This is the data that is written into the device (MSb first).

bit 8-15: data $DO(7:0)$ (read mode). This is the data that is read from the device (MSb first).

In multiple read/write commands further blocks of 8 clock periods is added. When \overline{MS} bit is '0' the address used to read/write data remains the same for every block. When \overline{MS} bit is '1' the address used to read/write data is increased at every block.

The function and the behavior of **SDI** and **SDO** remain unchanged.

6.2.1 SPI read

Figure 7. SPI read protocol

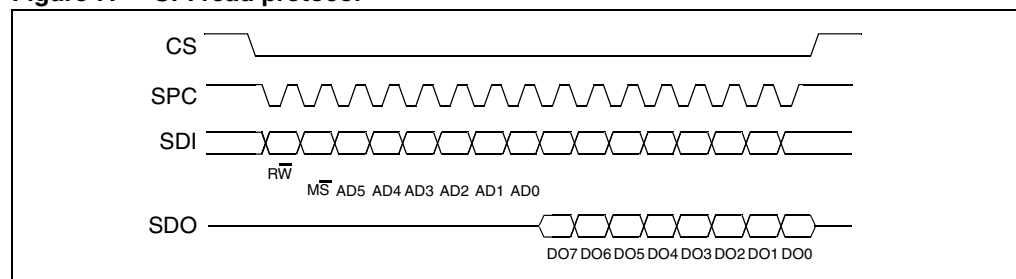

The SPI Read command is performed with 16 clock pulses. Multiple byte read command is performed adding blocks of 8 clock pulses at the previous one.

bit 0: READ bit. The value is 1.

bit 1: \overline{MS} bit. When 0 do not increment address, when 1 increment address in multiple reading.

bit 2-7: address $AD(5:0)$. This is the address field of the indexed register.

bit 8-15: data $DO(7:0)$ (read mode). This is the data that is read from the device (MSb first).

bit 16-... : data $DO(...-8)$. Further data in multiple byte reading.

Figure 8. Multiple bytes SPI read protocol (2 bytes example)

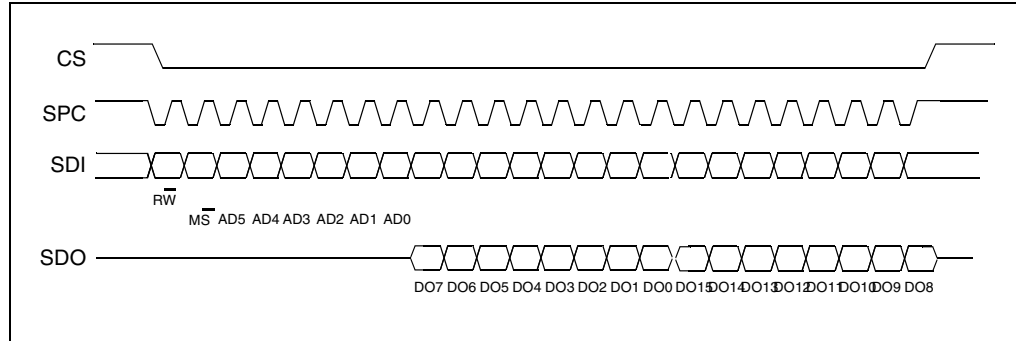

6.2.2 SPI write

Figure 9. SPI write protocol

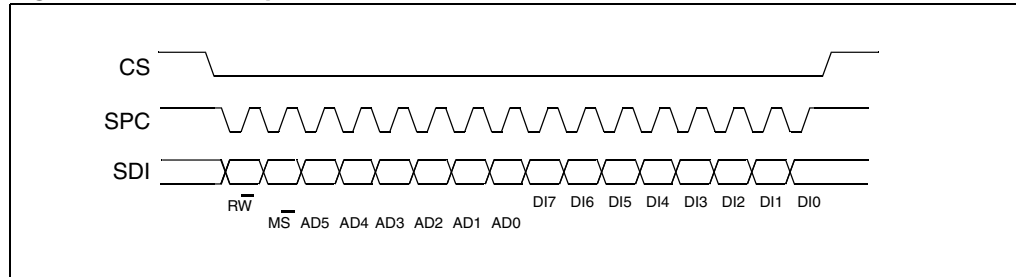

The SPI Write command is performed with 16 clock pulses. Multiple byte write command is performed adding blocks of 8 clock pulses at the previous one.

- bit 0:** WRITE bit. The value is 0.
- bit 1:** \overline{MS} bit. When 0 do not increment address, when 1 increment address in multiple writing.
- bit 2-7:** address AD(5:0). This is the address field of the indexed register.
- bit 8-15:** data DI(7:0) (write mode). This is the data that is written inside the device (MSb first).
- bit 16-...** : data DI(...-8). Further data in multiple byte writing.

Figure 10. Multiple bytes SPI write protocol (2 bytes example)

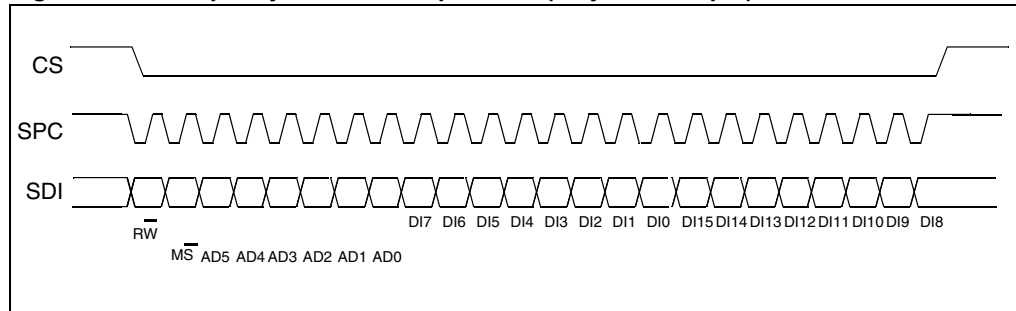

6.2.3 SPI read in 3-wires mode

3-wires mode is entered by setting to '1' bit SIM (SPI serial interface mode selection) in CTRL_REG4.

Figure 11. SPI read protocol in 3-wires mode

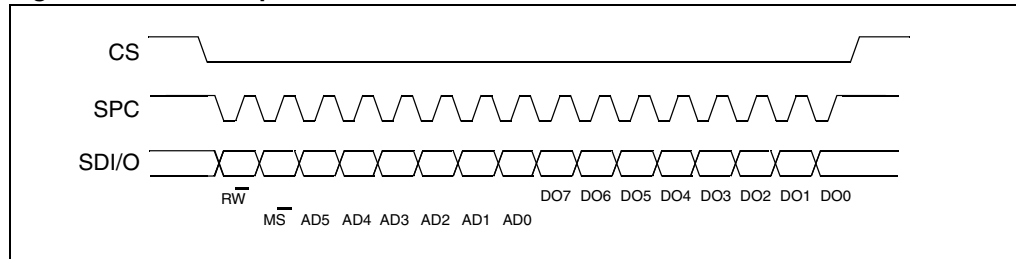

The SPI read command is performed with 16 clock pulses:

bit 0: READ bit. The value is 1.

bit 1: \overline{MS} bit. When 0 do not increment address, when 1 increment address in multiple reading.

bit 2-7: address AD(5:0). This is the address field of the indexed register.

bit 8-15: data DO(7:0) (read mode). This is the data that is read from the device (MSb first).

Multiple read command is also available in 3-wires mode.

7 Register mapping

The table given below provides a listing of the 8 bit registers embedded in the device and the related addresses:

Table 17. Register address map

Name	Type	Register address		Default	Comment
		Hex	Binary		
Reserved (do not modify)		00 - 06			Reserved
STATUS_REG_AUX	r	07	000 0111		
OUT_ADC1_L	r	08	000 1000	output	
OUT_ADC1_H	r	09	000 1001	output	
OUT_ADC2_L	r	0A	000 1010	output	
OUT_ADC2_H	r	0B	000 1011	output	
OUT_ADC3_L	r	0C	000 1100	output	
OUT_ADC3_H	r	0D	000 1101	output	
INT_COUNTER_REG	r	0E	000 1110		
WHO_AM_I	r	0F	000 1111	00110011	Dummy register
Reserved (do not modify)		10 - 1E			Reserved
TEMP_CFG_REG	rw	1F	001 1111		
CTRL_REG1	rw	20	010 0000	00000111	
CTRL_REG2	rw	21	010 0001	00000000	
CTRL_REG3	rw	22	010 0010	00000000	
CTRL_REG4	rw	23	010 0011	00000000	
CTRL_REG5	rw	24	010 0100	00000000	
CTRL_REG6	rw	25	010 0101	00000000	
REFERENCE	rw	26	010 0110	00000000	
STATUS_REG2	r	27	010 0111	00000000	
OUT_X_L	r	28	010 1000	output	
OUT_X_H	r	29	010 1001	output	
OUT_Y_L	r	2A	010 1010	output	
OUT_Y_H	r	2B	010 1011	output	
OUT_Z_L	r	2C	010 1100	output	
OUT_Z_H	r	2D	010 1101	output	
FIFO_CTRL_REG	rw	2E	010 1110	00000000	
FIFO_SRC_REG	r	2F	010 1111		
INT1_CFG	rw	30	011 0000	00000000	

Table 17. Register address map

Name	Type	Register address		Default	Comment
		Hex	Binary		
INT1_SOURCE	r	31	011 0001	00000000	
INT1_THS	rw	32	011 0010	00000000	
INT1_DURATION	rw	33	011 0011	00000000	
Reserved	rw	34-37		00000000	
CLICK_CFG	rw	38	011 1000	00000000	
CLICK_SRC	r	39	011 1001	00000000	
CLICK_THS	rw	3A	011 1010	00000000	
TIME_LIMIT	rw	3B	011 1011	00000000	
TIME_LATENCY	rw	3C	011 1100	00000000	
TIME_WINDOW	rw	3D	011 1101	00000000	

Registers marked as *Reserved* must not be changed. The writing to those registers may cause permanent damages to the device.

The content of the registers that are loaded at boot should not be changed. They contain the factory calibration values. Their content is automatically restored when the device is powered-up.

8 Registers description

8.1 STATUS_AUX (07h)

Table 18. STATUS_REG_AUX register

321OR	3OR	2OR	1OR	321DA	3DA	2DA	1DA
-------	-----	-----	-----	-------	-----	-----	-----

Table 19. STATUS_REG_AUX description

321OR	1, 2 and 3 axis data overrun. Default value: 0 (0: no overrun has occurred; 1: a new set of data has overwritten the previous ones)
3OR	3 axis data overrun. Default value: 0 (0: no overrun has occurred; 1: a new data for the 3-axis has overwritten the previous one)
2OR	2 axis data overrun. Default value: 0 (0: no overrun has occurred; 1: a new data for the 4-axis has overwritten the previous one)
1OR	1 axis data overrun. Default value: 0 (0: no overrun has occurred; 1: a new data for the 1-axis has overwritten the previous one)
321DA	1, 2 and 3 axis new data available. Default value: 0 (0: a new set of data is not yet available; 1: a new set of data is available)
3DA	3 axis new data available. Default value: 0 (0: a new data for the 3-axis is not yet available; 1: a new data for the 3-axis is available)
2DA	2 axis new data available. Default value: 0 (0: a new data for the 2-axis is not yet available; 1: a new data for the 2-axis is available)
1DA	1 axis new data available. Default value: 0 (0: a new data for the 1-axis is not yet available; 1: a new data for the 1-axis is available)

8.2 OUT_1_L (08h), OUT_1_H (09h)

1-axis acceleration data. The value is expressed in two's complement.

8.3 OUT_2_L (0Ah), OUT_2_H (0Bh)

2-axis acceleration data. The value is expressed in two's complement.

8.4 OUT_3_L (0Ch), OUT_3_H (0Dh)

3-axis acceleration data. The value is expressed in two's complement.

8.5 INT_COUNTER (0Eh)

Table 20. INT_COUNTER register

IC7	IC6	IC5	IC4	IC3	IC2	IC1	IC0
-----	-----	-----	-----	-----	-----	-----	-----

8.6 WHO_AM_I (0Fh)

Table 21. WHO_AM_I register

0	0	1	1	0	0	1	1
---	---	---	---	---	---	---	---

Device identification register.

8.7 TEMP_CFG_REG (1Fh)

Table 22. TEMP_CFG_REG register

ADC_PD	TEMP_EN	0	0	0	0	0	0
--------	---------	---	---	---	---	---	---

Table 23. TEMP_CFG_REG description

ADC_PD	ADC enable. Default value: 0 (0: ADC disabled; 1: ADC enabled)
TEMP_EN	Temperature sensor (T) enable. Default value: 0 (0: T disabled; 1: T enabled)

8.8 CTRL_REG1 (20h)

Table 24. CTRL_REG1 register

ODR3	ODR2	ODR1	ODR0	LPen	Zen	Yen	Xen
------	------	------	------	------	-----	-----	-----

Table 25. CTRL_REG1 description

ODR3-0	Data rate selection. Default value: 00 (0000:50 Hz; Others: Refer to Table 25 , "Data rate configuration")
LPen	Low power mode enable. Default value: 0 (0: normal mode, 1: low power mode)
Zen	Z axis enable. Default value: 1 (0: Z axis disabled; 1: Z axis enabled)
Yen	Y axis enable. Default value: 1 (0: Y axis disabled; 1: Y axis enabled)
Xen	X axis enable. Default value: 1 (0: X axis disabled; 1: X axis enabled)

ODR<3:0> is used to set power mode and ODR selection. In the following table are reported all frequency resulting in combination of ODR<3:0>

Table 26. Data rate configuration

ODR3	ODR2	ODR1	ODR0	Power mode selection
0	0	0	0	Power down mode
0	0	0	1	Normal / low power mode (1 Hz)
0	0	1	0	Normal / low power mode (10 Hz)
0	0	1	1	Normal / low power mode (25 Hz)
0	1	0	0	Normal / low power mode (50 Hz)
0	1	0	1	Normal / low power mode (100 Hz)
0	1	1	0	Normal / low power mode (200 Hz)
0	1	1	1	Normal / low power mode (400 Hz)
1	0	0	0	Low power mode (1.6 KHz)
1	0	0	1	Normal (1.25 kHz) / low power mode (5 KHz)

8.9 CTRL_REG2 (21h)

Table 27. CTRL_REG2 register

HPM1	HPM0	HPCF2	HPCF1	FDS	HPCLICK	HPIS2	HPIS1
------	------	-------	-------	-----	---------	-------	-------

Table 28. CTRL_REG2 description

HPM1 -HPM0	High pass filter mode selection. Default value: 00 Refer to Table 29, "High pass filter mode configuration"
HPCF2 - HPCF1	High pass filter cut off frequency selection
FDS	Filtered data selection. Default value: 0 (0: internal filter bypassed; 1: data from internal filter sent to output register and FIFO)
HPCLICK	High pass filter enabled for CLICK function. (0: filter bypassed; 1: filter enabled)
HPIS2	High pass filter enabled for AOI function on interrupt 2, (0: filter bypassed; 1: filter enabled)
HPIS1	High pass filter enabled for AOI function on interrupt 1, (0: filter bypassed; 1: filter enabled)

Table 29. High pass filter mode configuration

HPM1	HPM0	High pass filter mode
0	0	Normal mode (reset reading HP_RESET_FILTER)
0	1	Reference signal for filtering
1	0	Normal mode
1	1	Autoreset on interrupt event

8.10 CTRL_REG3 (22h)

Table 30. CTRL_REG3 register

I1_CLICK	I1_AOI1	I1_AOI2	I1_DRDY1	I1_DRDY2	I1_WTM	I1_OVERRUN	--
----------	---------	---------	----------	----------	--------	------------	----

Table 31. CTRL_REG3 description

I1_CLICK	CLICK interrupt on INT1. Default value 0. (0: Disable; 1: Enable)
I1_AOI1	AOI1 interrupt on INT1. Default value 0. (0: Disable; 1: Enable)
I1_AOI2	AOI2 interrupt on INT1. Default value 0. (0: Disable; 1: Enable)
I1_DRDY1	DRDY1 interrupt on INT1. Default value 0. (0: Disable; 1: Enable)
I1_DRDY2	DRDY2 interrupt on INT1. Default value 0. (0: Disable; 1: Enable)
I1_WTM	FIFO Watermark interrupt on INT1. Default value 0. (0: Disable; 1: Enable)
I1_OVERRUN	FIFO Overrun interrupt on INT1. Default value 0. (0: Disable; 1: Enable)

8.11 CTRL_REG4 (23h)

Table 32. CTRL_REG4 register

BDU	BLE	FS1	FS0	HR	ST1	ST0	SIM
-----	-----	-----	-----	----	-----	-----	-----

Table 33. CTRL_REG4 description

BDU	Block data update. Default value: 0 (0: continuous update; 1: output registers not updated until MSB and LSB reading)
BLE	Big/little endian data selection. Default value 0. (0: Data LSB @ lower address; 1: Data MSB @ lower address)
FS1-FS0	Full scale selection. default value: 00 (00: +/- 2G; 01: +/- 4G; 10: +/- 8G; 11: +/- 16G)

Table 33. CTRL_REG4 description (continued)

HR	High resolution output mode: Default value: 0 (0: High resolution disable; 1: High resolution Enable)
ST1-ST0	Self test enable. Default value: 00 (00: Self test disabled; Other: See Table 34)
SIM	SPI serial interface mode selection. Default value: 0 (0: 4-wire interface; 1: 3-wire interface).

Table 34. Self test mode configuration

ST1	ST0	Self test mode
0	0	Normal mode
0	1	Self test 0
1	0	Self test 1
1	1	--

8.12 CTRL_REG5 (24h)

Table 35. CTRL_REG5 register

BOOT	FIFO_EN	--	--	LIR_INT1	D4D_INT1	0	0
------	---------	----	----	----------	----------	---	---

Table 36. CTRL_REG5 description

BOOT	Reboot memory content. Default value: 0 (0: normal mode; 1: reboot memory content)
FIFO_EN	FIFO enable. Default value: 0 (0: FIFO disable; 1: FIFO Enable)
LIR_INT1	Latch interrupt request on INT1_SRC register, with INT1_SRC register cleared by reading INT1_SRC itself. Default value: 0. (0: interrupt request not latched; 1: interrupt request latched)
D4D_INT1	4D enable: 4D detection is enabled on INT1 when 6D bit on INT1_CFG is set to 1.

8.13 CTRL_REG6 (25h)

Table 37. CTRL_REG6 register

I2_CLICKen	I2_INT1	0	BOOT_I1	0	--	H_LACTIVE	-
------------	---------	---	---------	---	----	-----------	---

8.14 REFERENCE/DATACAPTURE (26h)

Table 38. REFERENCE register

Ref7	Ref6	Ref5	Ref4	Ref3	Ref2	Ref1	Ref0
------	------	------	------	------	------	------	------

Table 39. REFERENCE register description

Ref 7-Ref0	Reference value for Interrupt generation. Default value: 0
------------	--

8.15 STATUS_REG (27h)

Table 40. STATUS register

ZYXOR	ZOR	YOR	XOR	ZYXDA	ZDA	YDA	XDA
-------	-----	-----	-----	-------	-----	-----	-----

Table 41. STATUS register description

ZYXOR	X, Y and Z axis data overrun. Default value: 0 (0: no overrun has occurred; 1: a new set of data has overwritten the previous ones)
ZOR	Z axis data overrun. Default value: 0 (0: no overrun has occurred; 1: a new data for the Z-axis has overwritten the previous one)
YOR	Y axis data overrun. Default value: 0 (0: no overrun has occurred; 1: a new data for the Y-axis has overwritten the previous one)
XOR	X axis data overrun. Default value: 0 (0: no overrun has occurred; 1: a new data for the X-axis has overwritten the previous one)
ZYXDA	X, Y and Z axis new data available. Default value: 0 (0: a new set of data is not yet available; 1: a new set of data is available)
ZDA	Z axis new data available. Default value: 0 (0: a new data for the Z-axis is not yet available; 1: a new data for the Z-axis is available)
YDA	Y axis new data available. Default value: 0 (0: a new data for the Y-axis is not yet available; 1: a new data for the Y-axis is available)

8.16 OUT_X_L (28h), OUT_X_H (29h)

X-axis acceleration data. The value is expressed in two's complement.

8.17 OUT_Y_L (2Ah), OUT_Y_H (2Bh)

Y-axis acceleration data. The value is expressed in two's complement.

8.18 OUT_Z_L (2Ch), OUT_Z_H (2Dh)

Z-axis acceleration data. The value is expressed in two's complement.

8.19 FIFO_CTRL_REG (2Eh)

Table 42. REFERENCE register

FM1	FM0	TR	FTH4	FTH3	FTH2	FTH1	FTH0
-----	-----	----	------	------	------	------	------

Table 43. REFERENCE register description

FM1-FM0	FIFO mode selection. Default value: 00 (see Table 44)
TR	Trigger selection. Default value: 0 0: Trigger event linked to trigger signal on INT1 1: Trigger event linked to trigger signal on INT2
FTH4:0	Default value: 0

Table 44. FIFO mode configuration

FM1	FM0	Self test mode
0	0	Bypass mode
0	1	FIFO mode
1	0	Stream mode
1	1	Trigger mode

8.20 FIFO_SRC_REG (2Fh)

Table 45. FIFO_SRC register

WTM	OVFN_FIFO	EMPTY	FSS4	FSS3	FSS2	FSS1	FSS0
-----	-----------	-------	------	------	------	------	------

8.21 INT1_CFG (30h)

Table 46. INT1_CFG register

AOI	6D	ZHIE/ ZUPE	ZLIE/ ZDOWNE	YHIE/ YUPE	YLIE/ YDOWNE	XHIE/ XUPE	XLIE/ XDOWNE
-----	----	---------------	-----------------	---------------	-----------------	---------------	-----------------

Table 47. INT1_CFG description

AOI	And/Or combination of Interrupt events. Default value: 0. Refer to Table 48, "Interrupt mode"
6D	6 direction detection function enabled. Default value: 0. Refer to Table 48, "Interrupt mode"
ZHIE/ ZUPE	Enable interrupt generation on Z high event or on Direction recognition. Default value: 0 (0: disable interrupt request; 1: enable interrupt request)

Table 47. INT1_CFG description

ZLIE/ ZDOWNE	Enable interrupt generation on Z low event or on Direction recognition. Default value: 0 (0: disable interrupt request; 1: enable interrupt request)
YHIE/ YUPE	Enable interrupt generation on Y high event or on Direction recognition. Default value: 0 (0: disable interrupt request; 1: enable interrupt request.)
YLIE/ YDOWNE	Enable interrupt generation on Y low event or on Direction recognition. Default value: 0 (0: disable interrupt request; 1: enable interrupt request.)
XHIE/ XUPE	Enable interrupt generation on X high event or on Direction recognition. Default value: 0 (0: disable interrupt request; 1: enable interrupt request.)
XLIE/XDOWNE	Enable interrupt generation on X low event or on Direction recognition. Default value: 0 (0: disable interrupt request; 1: enable interrupt request.)

Content of this register is loaded at boot.

Write operation at this address is possible only after system boot.

Table 48. Interrupt mode

AOI	6D	Interrupt mode
0	0	OR combination of interrupt events
0	1	6 direction movement recognition
1	0	AND combination of interrupt events
1	1	6 direction position recognition

Difference between AOI-6D = '01' and AOI-6D = '11'.

AOI-6D = '01' is movement recognition. An interrupt is generate when orientation move from unknown zone to known zone. The interrupt signal stay for a duration ODR.

AOI-6D = '11' is direction recognition. An interrupt is generate when orientation is inside a known zone. The interrupt signal stay until orientation is inside the zone.

8.22 INT1_SRC (31h)

Table 49. INT1_SRC register

0	IA	ZH	ZL	YH	YL	XH	XL
---	----	----	----	----	----	----	----

Table 50. INT1_SRC description

IA	Interrupt active. Default value: 0 (0: no interrupt has been generated; 1: one or more interrupts have been generated)
ZH	Z high. Default value: 0 (0: no interrupt, 1: Z High event has occurred)
ZL	Z low. Default value: 0 (0: no interrupt; 1: Z Low event has occurred)
YH	Y high. Default value: 0 (0: no interrupt, 1: Y High event has occurred)

Table 50. INT1_SRC description

YL	Y low. Default value: 0 (0: no interrupt, 1: Y Low event has occurred)
XH	X high. Default value: 0 (0: no interrupt, 1: X High event has occurred)
XL	X low. Default value: 0 (0: no interrupt, 1: X Low event has occurred)

Interrupt 1 source register. Read only register.

Reading at this address clears INT1_SRC IA bit (and the interrupt signal on INT 1 pin) and allows the refreshment of data in the INT1_SRC register if the latched option was chosen.

8.23 INT1_THS (32h)

Table 51. INT1_THS register

0	THS6	THS5	THS4	THS3	THS2	THS1	THS0
---	------	------	------	------	------	------	------

Table 52. INT1_THS description

THS6 - THS0	Interrupt 1 threshold. Default value: 000 0000
-------------	--

8.24 INT1_DURATION (33h)

Table 53. INT1_DURATION register

0	D6	D5	D4	D3	D2	D1	D0
---	----	----	----	----	----	----	----

Table 54. INT1_DURATION description

D6 - D0	Duration value. Default value: 000 0000
---------	---

D6 - D0 bits set the minimum duration of the Interrupt 1 event to be recognized. Duration steps and maximum values depend on the ODR chosen.

8.25 CLICK_CFG (38h)

Table 55. CLICK_CFG register

--	--	ZD	ZS	YD	YS	XD	XS
----	----	----	----	----	----	----	----

Table 56. CLICK_CFG description

ZD	Enable interrupt double CLICK-CLICK on Z axis. Default value: 0 (0: disable interrupt request; 1: enable interrupt request on measured accel. value higher than preset threshold)
ZS	Enable interrupt single CLICK-CLICK on Z axis. Default value: 0 (0: disable interrupt request; 1: enable interrupt request on measured accel. value higher than preset threshold)
YD	Enable interrupt double CLICK-CLICK on Y axis. Default value: 0 (0: disable interrupt request; 1: enable interrupt request on measured accel. value higher than preset threshold)
YS	Enable interrupt single CLICK-CLICK on Y axis. Default value: 0 (0: disable interrupt request; 1: enable interrupt request on measured accel. value higher than preset threshold)
XD	Enable interrupt double CLICK-CLICK on X axis. Default value: 0 (0: disable interrupt request; 1: enable interrupt request on measured accel. value higher than preset threshold)
XS	Enable interrupt single CLICK-CLICK on X axis. Default value: 0 (0: disable interrupt request; 1: enable interrupt request on measured accel. value higher than preset threshold)

8.26 CLICK_SRC (39h)

Table 57. CLICK_SRC register

	IA	DCLICK	SCLICK	Sign	Z	Y	X
--	----	--------	--------	------	---	---	---

Table 58. CLICK_SRC description

-	-
IA	Interrupt active. Default value: 0 (0: no interrupt has been generated; 1: one or more interrupts have been generated)
DCLICK	Double CLICK-CLICK enable. Default value: 0 (0:double CLICK-CLICK detection disable, 1: double CLICK-CLICK detection enable)
SCLICK	Single CLICK-CLICK enable. Default value: 0 (0:Single CLICK-CLICK detection disable, 1: single CLICK-CLICK detection enable)
Sign	CLICK-CLICK Sign. 0: positive detection, 1: negative detection
Z	Z CLICK-CLICK detection. Default value: 0 (0: no interrupt, 1: Z High event has occurred)
Y	Y CLICK-CLICK detection. Default value: 0 (0: no interrupt, 1: Y High event has occurred)
X	X CLICK-CLICK detection. Default value: 0 (0: no interrupt, 1: X High event has occurred)

8.27 CLICK_THS (3Ah)

Table 59. CLICK_THS register

-	Ths6	Ths5	Ths4	Ths3	Ths2	Ths1	Ths0
---	------	------	------	------	------	------	------

Table 60. CLICK_SRC description

Ths6-Ths0	CLICK-CLICK threshold. Default value: 000 0000
-----------	--

8.28 TIME_LIMIT (3Bh)

Table 61. TIME_LIMIT register

-	TLI6	TLI5	TLI4	TLI3	TLI2	TLI1	TLI0
---	------	------	------	------	------	------	------

Table 62. TIME_LIMIT description

TLI7-TLI0	CLICK-CLICK Time Limit. Default value: 000 0000
-----------	---

8.29 TIME_LATENCY (3Ch)

Table 63. TIME_LATENCY register

TLA7	TLA6	TLA5	TLA4	TLA3	TLA2	TLA1	TLA0
------	------	------	------	------	------	------	------

Table 64. TIME_LATENCY description

TLA7-TLA0	CLICK-CLICK time latency. Default value: 000 0000
-----------	---

8.30 TIME_WINDOW(3Dh)

Table 65. TIME_WINDOW register

TW7	TW6	TW5	TW4	TW3	TW2	TW1	TW0
-----	-----	-----	-----	-----	-----	-----	-----

Table 66. TIME_WINDOW description

TW7-TW0	CLICK-CLICK time window
---------	-------------------------

9 Package information

In order to meet environmental requirements, ST offers these devices in different grades of ECOPACK[®] packages, depending on their level of environmental compliance. ECOPACK[®] specifications, grade definitions and product status are available at: www.st.com. ECOPACK is an ST trademark.

Table 67. LGA-16: Mechanical data

Dim	mm		
	Min.	Typ.	Max.
A1			1
A2		0.785	
A3		0.2	
D1	2.85	3	3.15
E1	2.85	3	3.15
L1		1	1.06
L2		2	2.06
N1		0.5	
N2		1	
M	0.04	0.1	0.16
P1		0.875	
P2		1.275	
T1	0.29	0.35	0.41
T2	0.19	0.25	0.31
d		0.15	
k		0.05	

Figure 12. LGA-16: Mechanical data and package dimensions

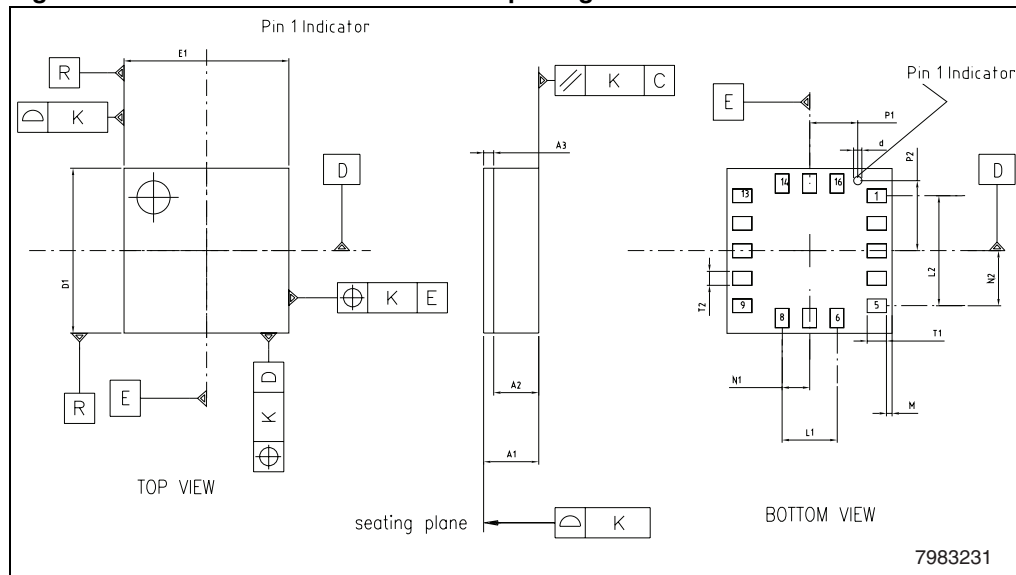

10 Revision history

Table 68. Document revision history

Date	Revision	Changes
21-May-2010	1	Initial release

Please Read Carefully:

Information in this document is provided solely in connection with ST products. STMicroelectronics NV and its subsidiaries ("ST") reserve the right to make changes, corrections, modifications or improvements, to this document, and the products and services described herein at any time, without notice.

All ST products are sold pursuant to ST's terms and conditions of sale.

Purchasers are solely responsible for the choice, selection and use of the ST products and services described herein, and ST assumes no liability whatsoever relating to the choice, selection or use of the ST products and services described herein.

No license, express or implied, by estoppel or otherwise, to any intellectual property rights is granted under this document. If any part of this document refers to any third party products or services it shall not be deemed a license grant by ST for the use of such third party products or services, or any intellectual property contained therein or considered as a warranty covering the use in any manner whatsoever of such third party products or services or any intellectual property contained therein.

UNLESS OTHERWISE SET FORTH IN ST'S TERMS AND CONDITIONS OF SALE ST DISCLAIMS ANY EXPRESS OR IMPLIED WARRANTY WITH RESPECT TO THE USE AND/OR SALE OF ST PRODUCTS INCLUDING WITHOUT LIMITATION IMPLIED WARRANTIES OF MERCHANTABILITY, FITNESS FOR A PARTICULAR PURPOSE (AND THEIR EQUIVALENTS UNDER THE LAWS OF ANY JURISDICTION), OR INFRINGEMENT OF ANY PATENT, COPYRIGHT OR OTHER INTELLECTUAL PROPERTY RIGHT.

UNLESS EXPRESSLY APPROVED IN WRITING BY AN AUTHORIZED ST REPRESENTATIVE, ST PRODUCTS ARE NOT RECOMMENDED, AUTHORIZED OR WARRANTED FOR USE IN MILITARY, AIR CRAFT, SPACE, LIFE SAVING, OR LIFE SUSTAINING APPLICATIONS, NOR IN PRODUCTS OR SYSTEMS WHERE FAILURE OR MALFUNCTION MAY RESULT IN PERSONAL INJURY, DEATH, OR SEVERE PROPERTY OR ENVIRONMENTAL DAMAGE. ST PRODUCTS WHICH ARE NOT SPECIFIED AS "AUTOMOTIVE GRADE" MAY ONLY BE USED IN AUTOMOTIVE APPLICATIONS AT USER'S OWN RISK.

Resale of ST products with provisions different from the statements and/or technical features set forth in this document shall immediately void any warranty granted by ST for the ST product or service described herein and shall not create or extend in any manner whatsoever, any liability of ST.

ST and the ST logo are trademarks or registered trademarks of ST in various countries.

Information in this document supersedes and replaces all information previously supplied.

The ST logo is a registered trademark of STMicroelectronics. All other names are the property of their respective owners.

© 2010 STMicroelectronics - All rights reserved

STMicroelectronics group of companies

Australia - Belgium - Brazil - Canada - China - Czech Republic - Finland - France - Germany - Hong Kong - India - Israel - Italy - Japan - Malaysia - Malta - Morocco - Philippines - Singapore - Spain - Sweden - Switzerland - United Kingdom - United States of America

www.st.com