

One sensor, unlimited ideas

Standalone MEMS accelerometer with excellent durability

1-axis accelerometer GF1





AGF10711



AGF11311

FEATURES

- High reliability: superior offset voltage temperature characteristics (33 mg (typ.))
- Fast response: 100 m/s
- Compact size: 58×36.5×33mm 2.283×1.437×1.299inch (without bracket)

APPLICATIONS

- Inclination detection (for improved safety and operability) in agricultural machine, construction machine and mobility vehicles
- Photovoltaic station power plant: Solar tracking for panels
- Automotive: 4WD ABS control and idling stop system

Compliance with RoHS Directive

ORDERING INFORMATION

AGF 1 □ □ 1 1

Number of detectable axis (Method)
1: 1-axis accelerometer
(Electrostatic capacitance type)

Shape
0: Without bracket
1: With bracket

Detection sensitivity
3: 1.333V/g
7: 3.0V/g

Operation power supply voltage
1: 5 V DC

Installation direction type
1: Horizontal type

PRODUCT TYPES

Product name	Operation power supply voltage	Acceleration detection range	Detection sensitivity	Part number
1-axis accelerometer GF1	5V DC	±0.5g	3.0V/g	AGF10711
		±1.2g	1.333V/g	AGF11311

Note: Carton: 80 pcs. (with bracket), Case: 150 pcs. (without bracket)

MAXIMUM RATING

Item	Unit	Standard value			Remarks
		min.	typ.	max.	
Maximum allowable voltage	V	-0.3	—	7	Ta=20°C 68°F
Maximum applied acceleration	m/s ² (g)	—	—	49 (5)	
		—	—	147 (15)	
Storage temperature range	°C °F	-30 -22	—	85 185	
Operation temperature range	°C °F	-30 -22	—	85 185	
Anti-shock characteristic	m/s ² (g)	—	—	49,000 (5,000)	
Grade of protection		IP67			

ELECTRICAL CHARACTERISTICS

Item	Unit	Standard value						Remarks
		min.		typ.		max.		
		AGF10711	AGF11311	AGF10711	AGF11311	AGF10711	AGF11311	
Acceleration detection range*1	m/s ² (g)	-4.9 (-0.5)	-11.76 (-1.2)	—		4.9 (0.5)	11.76 (1.2)	
Operation power supply voltage	V	4.75		5		5.25		-30 to +85°C -22 to +185°F
Current consumption	mA	—		—		10		0g, Ta=20°C 68°F
Sensitivity	mV/(m/s ²) (mV/g)	297 (2910)	132 (1293)	306 (3000)	136 (1333)	315 (3090)	140 (1373)	-30 to +85°C -22 to +185°F
Offset voltage (0 g)	V	2.4		2.5		2.6		Ta=20°C 68°F
Offset voltage temperature characteristic	V (mg)	-0.21 (-70)	-0.093 (-70)	—		0.21 (70)	0.093 (70)	-30 to +85°C -22 to +185°F
Other axis sensitivity	%	-5		—		5		Ta=20°C 68°F
Non-linearity*2	%FS	-1		—		1		Ta=20°C 68°F
Turn-on time	ms	—		10		—		0g, Ta=20°C 68°F
Frequency response	Hz	DC		15		—		-3dB point
Clamping voltage VH	V	4.4		4.5		4.6		
Clamping voltage VL	V	0.4		0.5		0.6		

Notes: 1. The acceleration unit "g" means 9.8 m/s².
 2. Maximum error from linear output that connects +1.2 g and -1.2 g output. (AGF11311)
 Maximum error from linear output that connects +0.5 g and -0.5 g output. (AGF10711)

REFERENCE DATA

1. Output characteristics

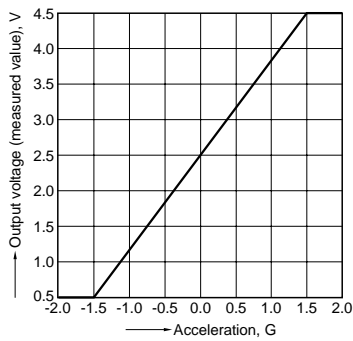

2. Inclination angle - Output voltage characteristics

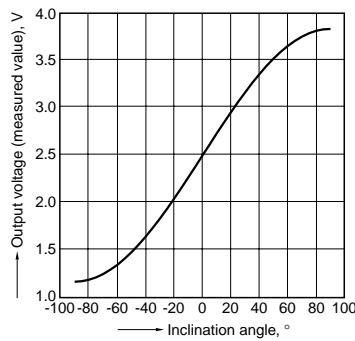

3. Sensitivity temperature characteristics

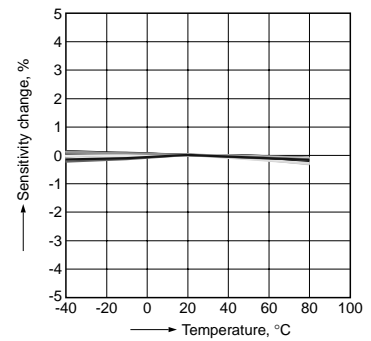

4. Offset voltage temperature characteristics

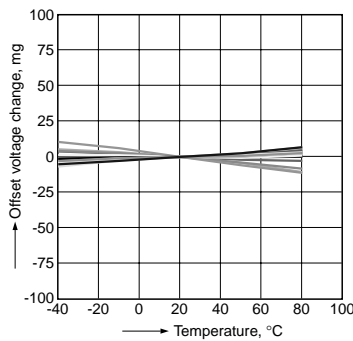

5. Frequency characteristics

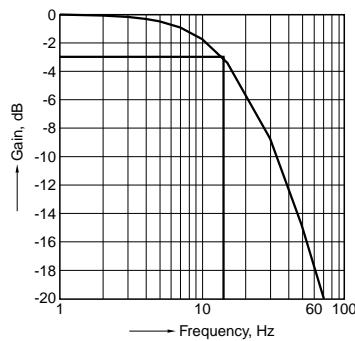

AGF1

DIMENSIONS (mm inch)

The CAD data of the products with a **CAD Data** mark can be downloaded from: <http://panasonic-electric-works.net/ac>

Without bracket (AGF10711)

CAD Data

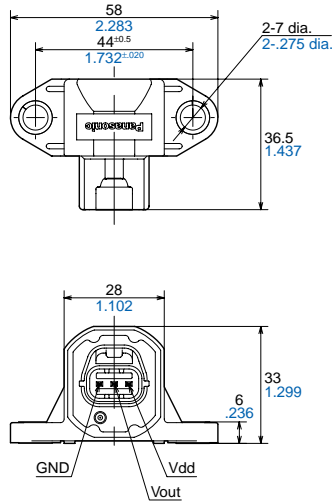

Connector:
Manufacturing company: Yazaki Corporation
Housing: 7283-8730-30

With bracket (AGF11311)

CAD Data

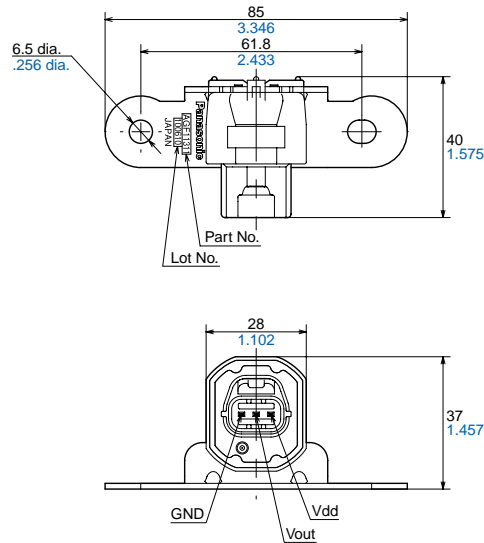

Connector:
Manufacturing company: Yazaki Corporation
Housing: 7283-8730-30

WIRING DIAGRAM

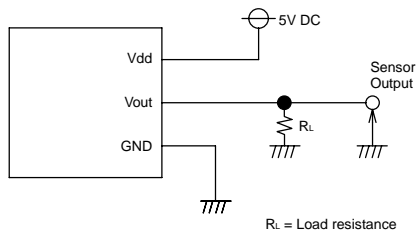

NOTES

1. To ensure reliability, please verify quality under conditions of actual use

2. Connections

- Please perform connections correctly in accordance with the terminal connection diagram. In particular, be careful not to reverse wire the power supply as this will cause damage or degrade to the product.

3. Cleaning

- Avoid ultrasonic cleaning since this may cause breaks or disconnections in the wiring.

4. Environment

- Please avoid using or storing the sensor in a place exposed to corrosive gases (such as the gases given off by organic solvents, sulfurous acid gas, hydrogen sulfides, etc.) which will adversely affect the performance of the sensor.
- Since the internal circuitry may be destroyed if an external surge voltage is supplied, provide an element which will absorb the surges.
- Malfunctioning may occur if the product is in the vicinity of electrical noise such as that from static electricity, lightning, a broadcasting station, an amateur radio, or a mobile phone.
- Avoid using the sensor in an environment where condensation may form. Furthermore, its output may fluctuate if any moisture adhering to it freezes.
- Avoid using the sensor where it will be susceptible to ultrasonic or other high-frequency vibration.
- Please do not use the sensor in a location subject to direct sunlight or in a location subject to a similar strong light source.

5. Other handling precautions

To assure reliability, check the sensor under actual loading conditions. Avoid any situation that may adversely affect its performance.

- Caution is required because differences in the acceleration detection range and the method of connection can lead to accidents.
- The actual acceleration should be within the rated acceleration range. Damage may occur if it is outside of this range.
- This product may become damaged if exposed to static electricity. Therefore, please be careful when handling.