

728-019 to 159  
728-263 to 342  
728-408/410

# Heavy Duty Connectors Han-Modular<sup>®</sup>

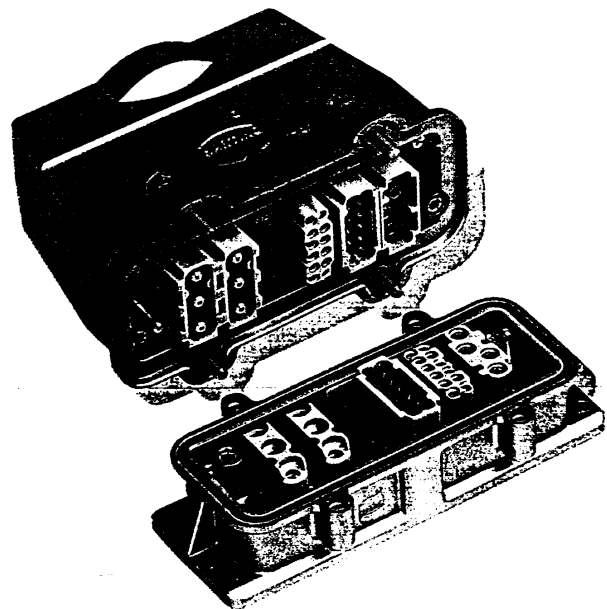

Certified according to DIN ISO 9001  
in design/development, production,  
installation and servicing



## The best connections world-wide - connect with quality - specify HARTING

HARTING Elektronik GmbH was founded in 1945 and is 100 % privately owned.

Approximately 1,700 people are employed worldwide including 150 engineers and more than 100 sales engineers who provide the daily interface with our customers.

HARTING with its 16 subsidiaries in Europe, North America and Asia is today one of the world's leading connector manufacturers.

All the company's manufacturing plants, with the exception of Plant 1 in Espelkamp, have been built within the last ten years.

State of the art CAD-Systems are used both in the R & D department and the tool making department in order to bring new products to the market in the most efficient way.

It is HARTING's philosophy that the target of permanent zero defect production is only achievable by the integration of fully automatic in-line inspection processes.

The implementation of the above quality philosophy and associated processes are documented according to DIN ISO 9001 in the Quality Assurance Manual.

In total approximately 60 quality control personnel are employed. The majority of these engineers and technicians are trained and certified by the German (DCQ) or Swiss (SAQ) quality organisations. The divisions electronic connectors, heavy duty connectors Han® and solenoids are certified according to DIN ISO 9001 for design/R & D, production, assembly and customer service.

The dedication to quality and the ability to deliver on a "Just in Time" basis have led to the development of strong relationships with leading original equipment manufacturers on the world market.

HARTING is the market leader in several of its product ranges.

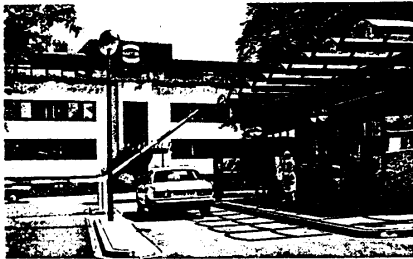

Germany - Plant 1 Espelkamp

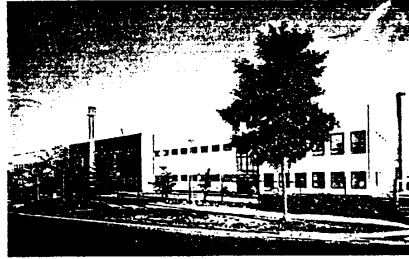

Germany - Plant 2 Espelkamp



Germany - Plant 3 Espelkamp



France - Sales and marketing

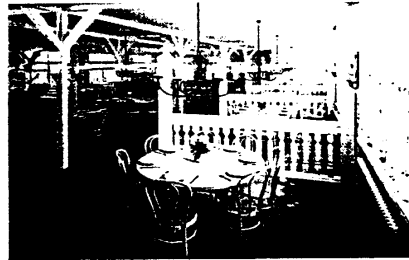

Espelkamp - Staff Cafeteria

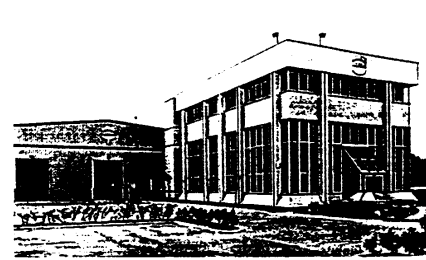

United Kingdom - Production, sales and marketing

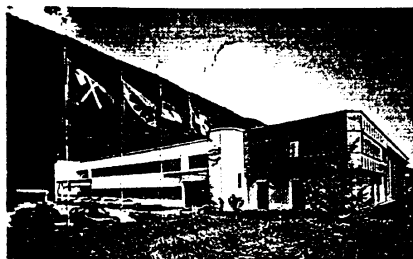

Switzerland - Production plant



Hong Kong - Production, sales and marketing

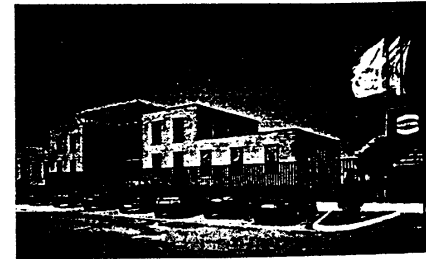

Italy - Sales and marketing

● Han-Modular®	page
Specifications, Approvals	06.02
Description of the Han-Modular® system	06.03
Summary	06.05
● Frames	06.10
Han C-module	06.12
Han E-module	06.14
Han DD-module	06.16
Han Multicontact-module	06.18
Han Pneumatic-module	06.20
● Harnessing alternatives	06.22
Standard hoods	06.23
Hoods for special applications	06.34
Accessories	06.35
Crimping tools	06.37
● List of part numbers	06.43

## Economic and Reliable Connections

### Specifications

VDE 0110 table 4, concerning clearances and creepage-distances

VDE 0627 Connectors

### Note

**Connectors should not be coupled and decoupled under electrical load. Connectors of the same or different series being mounted side by side may be protected against incorrect mating by the use of coding options.**

### Approvals

UL, CSA, SEV for inserts and hoods/housings

Han M hoods/housings for harsh environmental requirements  
·DET NORSKE VERITAS (DNV)

Han U hoods/housings for intrinsically safe plant

State mining board  
BVS-certification no. T 6365

CERCHAR-France  
"MS 83.9011 U"

SABS  
South African Bureau of Standards



Certified according to DIN ISO 9001 in design/development, production, installation and servicing

### Terminations

- Screw terminal
- Crimp terminal
- Solder terminal

### Inserts

- Leading protective ground
- Polarised for correct mating
- Interchangeability of male and female inserts in hoods and housings
- Captive fixing screws
- Can be used with hoods and housings, or for rack and panel applications
- Compact design
- Power and signal contacts of different media in one connector

### Hoods/Housings

- Standard Hoods/Housings IP 65
- Hoods/Housings for harsh environmental requirements IP 65
- Hoods/Housings for intrinsically safe plant
- Degree of protection IP 65
- Pressure tight housings IP 68
- EMC Hoods/Housings
- Electrical connection with protective ground
- High mechanical strength and vibration-resistance ensured by locking levers
- Spring-loaded and lockable covers in shockproof thermoplastic or metal

### Accessories

- Extensive range of cable protection and sealing accessories
- Protective covers available

For "non standard applications" we can manufacture designs to match your requirements.  
Please discuss requirements with us.

HARTING-heavy duty connectors incorporate the latest design features and provide the assurance of high quality and reliability with economy.

Sales Department  
HARTING-Components

### General information

06  
02 It is the user's responsibility to check whether the components illustrated in this catalogue comply with different regulations from those stated in special fields of application which we are unable to foresee.

We reserve the right to modify designs in order to improve quality, keep pace with technological advancement or meet particular requirements in production.

This catalogue must not be used in any form or manner without our prior approval in writing (Copyright Law, Fair Trading Law, Civil Code).  
We are bound by the German version only.

## Description of the Han-Modular® system

The **Han-Modular®** series is a new system of inserts designed to meet the specific requirements of individual customers. In close cooperation with potential users a range of modular inserts have been developed allowing the simple assembly of custom designed complete connectors which meet the diverse requirements encountered by today's designers.

**Han-Modular®** is a logical development of the **Han-Com®** series which already offers the combination of power and signal circuits in one connector.

The individual modules of this series now allow the integration of **electrical, optical and gaseous** signal and power connections in one connector assembly.

The pneumatic contacts are also suitable for the connection of liquid media. However it must be stated that a combination of electrical and liquid connections in one connector is not allowed according to VDE regulations.

The individual contacts used in this system are all from existing well proven ranges and it is possible to use combinations of 2 to 12 modules depending on the size of the hoods and housings chosen.

The basic modules snap into a mounting frame and can be exchanged separately at any time.

### Advantages:

- Custom designs can be simply assembled
- Optimum solutions can be reached
- Stock can be minimized

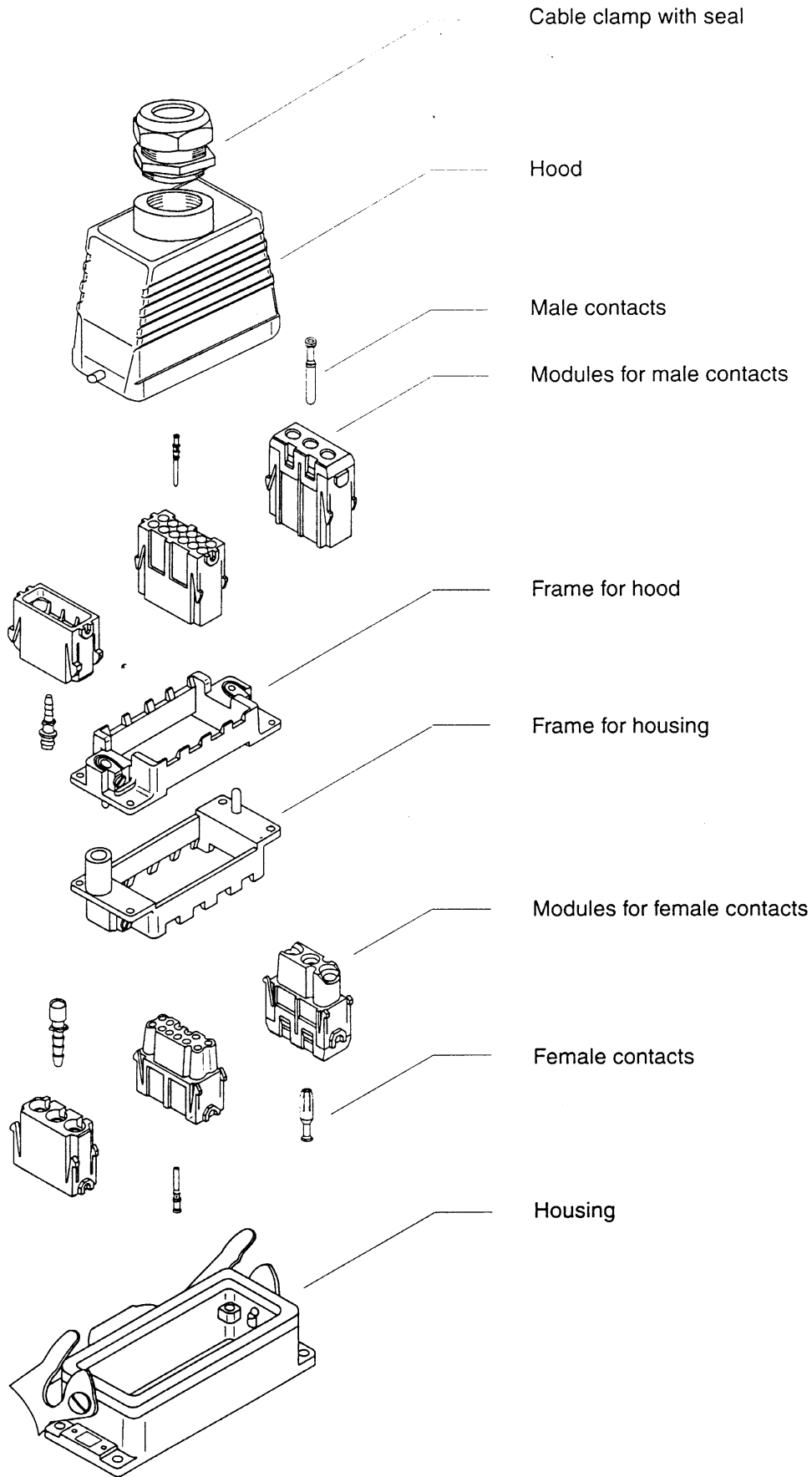

## Summary

### 1. Frame

Frame for	Suitable Han®-B-hoods/housings size
2 modules	6
3 modules	10
4 modules	16
6 modules	24
2 x 4 modules	32
2 x 6 modules	48

### 2. Modules

Type	Medium	Termination	Working current [A]		Working voltage [V ~]
			[bar]	[psi]	
Han C-module	electric	crimp	40		400 / 690
Han E-module	electric	crimp	16		500
Han DD-module - for signal contacts - for 1 mm POF* contacts	electric	crimp	10		250
	fibre optics	crimp			
Han Multicontact-module - for coaxial contacts (50 Ω) - for high voltage contacts (1.0 kV) - for FOC GI-fibre - for FOC 1 mm POF* contacts	electric	crimp/solder	1.5		50
	electric	solder	1.5		1000
	fibre optics	glue			
	fibre optics	crimp/glue			
			Working pressure		Tube termination ID [mm]
			[bar]	[psi]	
Han Pneumatic-module	air and liquid media	plug	8	116	1.6; 3.0 and 4.0

\* POF = Polymer Optical Fibre

## Frames



## Features

- Grounding system according to VDE
- Torsion-rigid die cast zinc frame
- one part frame
- Modules can only be snapped in polarized to guarantee correct orientation
- Alternatively use of male and female modules within one frame
- Frames are usable in standard hoods/housings
- Alphabetical marking of module positions

## Technical characteristics

Termination gauge for the PE-wire

Power side: 4 - 6 mm<sup>2</sup> / AWG 12 - AWG 10

Signal side: 1 - 2.5 mm<sup>2</sup> / AWG 18 - AWG 14

Material: die cast zinc alloy



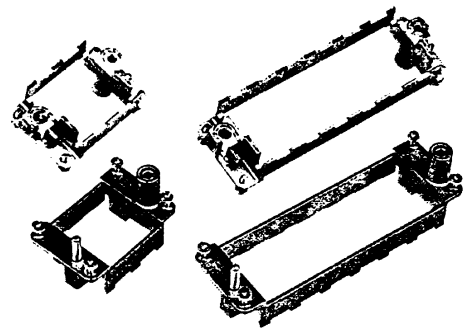

Frames

Identification	Part No. for Hood / Housing <sup>2)</sup>		Drawing	Dimensions in mm
	Marking: A ... F	Marking: a ... f		
Frame for 2 modules	09 14 006 0301	09 14 006 0311		
Frame for 3 modules	09 14 010 0301	09 14 010 0311		
Frame for 4 modules	09 14 016 0301	09 14 016 0311		
Frame for 6 modules	09 14 024 0301	09 14 024 0311		

<sup>1)</sup> Distance for electrical and FOC contacts max. 21 mm; for pneumatic contacts max. 20.5 mm  
<sup>2)</sup> Frames can be used either in hood or housing, but two different markings must be used for one connector

## Features

- 3 contacts (40 A) for power circuits
- Male insert with additional protection collar
- Polarization of module
- Crimp termination

## Technical characteristics

Specifications  
 DIN VDE 0627  
 DIN VDE 0110

### Approvals

Inserts  
 Number of contacts 3  
 Working current 40 A  
 Working voltage 400 / 690 V ~  
 Pollution degree 3 (C)  
 Material Polycarbonate  
 Insulation resistance  $\geq 10^{10} \Omega$   
 Temperature range - 40 °C + 125 °C  
 Flammability acc. to UL 94 V 0  
 Mechanical working life  
 - mating cycles  $\geq 500$

Contacts  
 Material copper alloy  
 Surface  
 - hard-silver plated 5  $\mu\text{m}$  Ag  
 Contact resistance  $\leq 0.3 \text{ m}\Omega$   
 Crimp terminal  
 -  $\text{mm}^2$  1.5 - 6  
 - AWG 16 - 10

### Current carrying capacity

The current carrying capacity is limited by maximum temperature of materials for inserts and contacts including terminals. The current capacity-curve is valid for continuous, not interrupted current-loaded contacts of connectors when simultaneous power on all contacts is given, without exceeding the maximum temperature.

Control and test procedures according to DIN IEC 512-3.

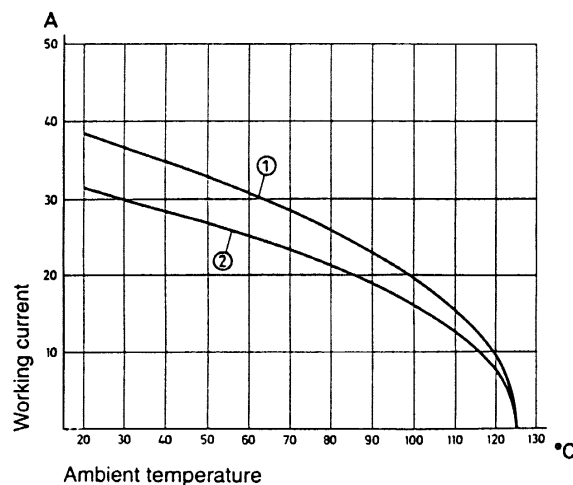

- ① 24 B hood/housing with 6 modules; wire gauge: 6.0  $\text{mm}^2$
- ② 24 B hood/housing with 6 modules; wire gauge: 4.0  $\text{mm}^2$

Number of contacts

# 3



Han® C-module

Identification      Part No.      Male insert (M)      Female insert (F)      Drawing      Dimensions in mm

Crimp terminal

Order contacts separately

09 14 003 3001

09 14 003 3101

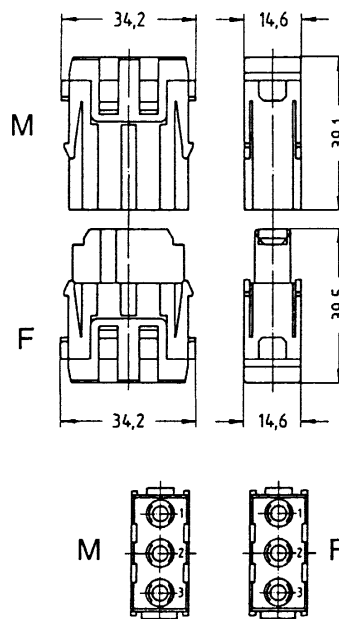

Contact arrangement View from termination side

Identification

Crimp contacts

Power contacts

silver plated



Wire gauge (mm²)      Part No.      Male contacts      Female contacts      Drawing      Dimensions in mm



1.5	09 32 000 6104	09 32 000 6204
2.5	09 32 000 6105	09 32 000 6205
4.0	09 32 000 6107	09 32 000 6207
6.0	09 32 000 6108	09 32 000 6208

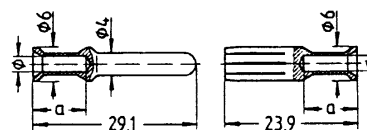

ø	Wire gauge		a
	mm²	AWG	
1.75	1.5 mm²	AWG 16	9
2.25	2.5 mm²	AWG 14	9
2.85	4 mm²	AWG 12	9.6
3.5	6 mm²	AWG 10	9.6



Features

- ❑ 6 contacts (16 A) for power circuits
- ❑ Male insert with additional protection collar
- ❑ Polarization of module
- ❑ Crimp termination
- ❑ Contacts with silver and gold plated surface

Technical characteristics

Specifications DIN VDE 0627  
DIN VDE 0110

Approvals

Inserts

Number of contacts	6
Working current	16 A
Working voltage	500 V ~
Pollution degree	3 (C)
Material	Polycarbonate
Insulation resistance	≥ 10 <sup>10</sup> Ω
Temperature range	- 40 °C + 125 °C
Flammability acc. to UL 94	V0
Mechanical working life	
- mating cycles	≥ 500

Contacts

Material	copper alloy
Surface	
- hard-silver plated	3 μm Ag
- hard-gold plated	2 μm Au over 3 μm Ni
Contact resistance	≤ 1 mΩ
Crimp terminal	
- mm <sup>2</sup>	0.5 - 4 mm <sup>2</sup>
- AWG	20 - 12

Current carrying capacity

The current carrying capacity is limited by maximum temperature of materials for inserts and contacts including terminals. The current capacity-curve is valid for continuous, not interrupted current-loaded contacts of connectors when simultaneous power on all contacts is given, without exceeding the maximum temperature.

Control and test procedures according to DIN IEC 512-3.

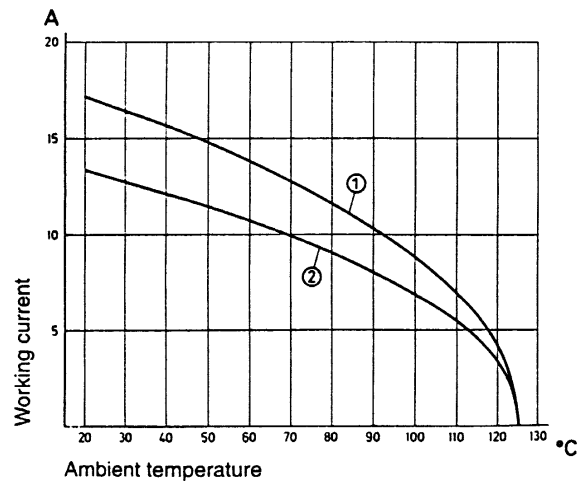

- ① 24 B hood/housing with 6 modules; wire gauge: 2.5 mm<sup>2</sup>
- ② 24 B hood/housing with 6 modules; wire gauge: 1.5 mm<sup>2</sup>

Number of contacts

# 6

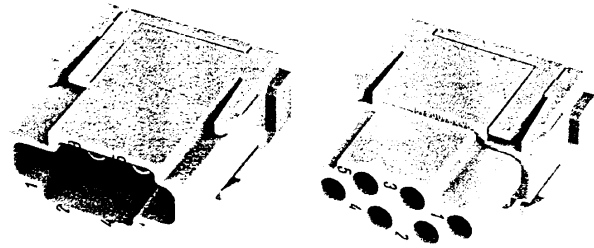

Han® E-module

Identification      Part No.      Male insert (M)      Female insert (F)      Drawing      Dimensions in mm

Crimp terminal

Order contacts separately

09 14 006 3001

M

09 14 006 3101

F

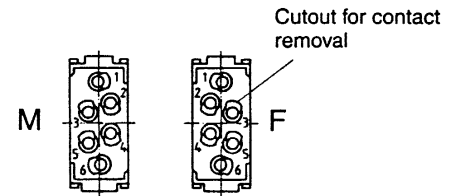
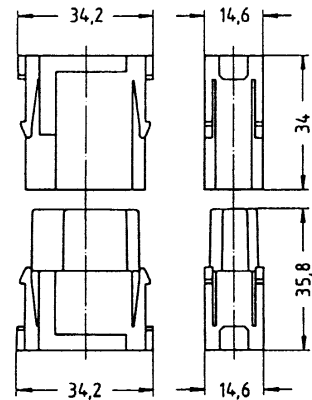

Contact arrangement View from termination side

Identification      Wire gauge (mm<sup>2</sup>)      Part No.      Male contacts      Female contacts      Drawing      Dimensions in mm

Crimp contacts

Power contact

silver plated



gold plated



Relay contact

silver plated



Wire gauge (mm <sup>2</sup> )	Part No.	Male contacts	Female contacts
0.5	09 33 000 6121	09 33 000 6121	09 33 000 6220
0.75	09 33 000 6114	09 33 000 6114	09 33 000 6214
1.0	09 33 000 6105	09 33 000 6105	09 33 000 6205
1.5	09 33 000 6104	09 33 000 6104	09 33 000 6204
2.5	09 33 000 6102	09 33 000 6102	09 33 000 6202
4.0	09 33 000 6106	09 33 000 6106	09 33 000 6206
4.0	09 33 000 6107	09 33 000 6107	09 33 000 6207
0.5	09 33 000 6122	09 33 000 6122	09 33 000 6222
0.75	09 33 000 6115	09 33 000 6115	09 33 000 6215
1.0	09 33 000 6118	09 33 000 6118	09 33 000 6218
1.5	09 33 000 6116	09 33 000 6116	09 33 000 6216
2.5	09 33 000 6123	09 33 000 6123	09 33 000 6223
4.0	09 33 000 6119	09 33 000 6119	09 33 000 6221
0.75	09 33 000 6109	09 33 000 6109	
1.5	09 33 000 6110	09 33 000 6110	
2.5	09 33 000 6111	09 33 000 6111	

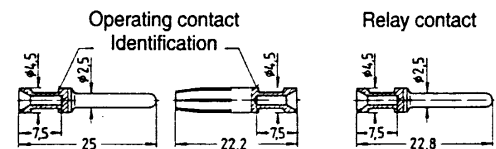

Crimp contact identification

Identification	Wire gauge	Stripping length
no groove	0.5 mm <sup>2</sup>	AWG 20
1 groove*	0.75 mm <sup>2</sup>	AWG 18
1 groove	1 mm <sup>2</sup>	AWG 18
2 grooves	1.5 mm <sup>2</sup>	AWG 16
3 grooves	2.5 mm <sup>2</sup>	AWG 14
wide groove	3.0 mm <sup>2</sup>	AWG 12
no groove	4 mm <sup>2</sup>	AWG 12

\* on the back crimp collar

## Features

- 12 contact chambers for
  - Signal contacts (10 A)
  - FOC contacts for 1 mm plastic fibre
- Male insert with additional protection collar
- Polarization of module
- Crimp termination
- Signal contacts with silver respectively gold plated surface
- Alternatively use of male and female modules within one frame
- Contact spacing enables the use of pcb-adaptors (see page 06.36)

## Technical characteristics

Specifications DIN VDE 0627  
DIN VDE 0110

### Approvals

#### Inserts

Number of contacts	12
Working current	10 A
Working voltage	250 V ~
Pollution degree	3 (C)
Material	Polycarbonate
Insulation resistance	$\geq 10^{10} \Omega$
Temperature range	- 40 °C + 125 °C
Flammability acc. to UL 94	V0
Mechanical working life	$\geq 500$
- mating cycles	

#### Contacts

Material	copper alloy
Surface	
- hard-silver plated	3 $\mu\text{m}$ Ag
- hard-gold plated	2 $\mu\text{m}$ Au over 3 $\mu\text{m}$ Ni
Contact resistance	$\leq 3 \text{ m}\Omega$
Crimp terminal	
- mm <sup>2</sup>	0.14 - 2.5 mm <sup>2</sup>
- AWG	26 - 14

#### Locking clip

Material	non-corroding spring steel
----------	-------------------------------

### Current carrying capacity

The current carrying capacity is limited by maximum temperature of materials for inserts and contacts including terminals. The current capacity-curve is valid for continuous, not interrupted current-loaded contacts of connectors when simultaneous power on all contacts is given, without exceeding the maximum temperature.

Control and test procedures according to DIN IEC 512-3.

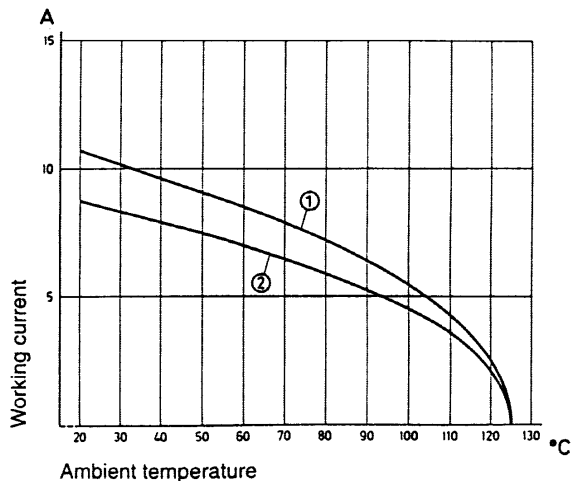

- ① 24 B hood/housing with 6 modules; wire gauge: 1.5 mm<sup>2</sup>
- ② 24 B hood/housing with 6 modules; wire gauge: 1.0 mm<sup>2</sup>

Number of contacts

# 12

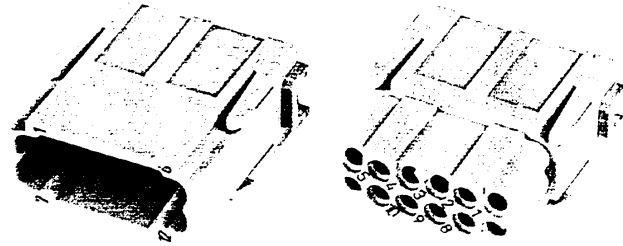

Han® DD-module

Identification      Part No.      Male insert (M)      Female insert (F)      Drawing      Dimensions in mm

Crimp terminal

Order contacts separately

09 14 012 3001

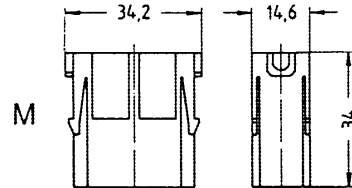

09 14 012 3101

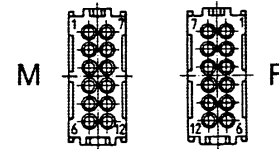
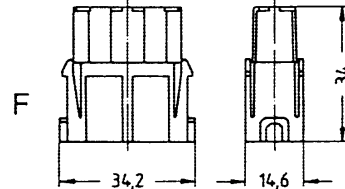

Contact arrangement View from termination side

Identification      Wire gauge (mm²)      Part No.      Male contacts      Female contacts      Drawing      Dimensions in mm

Crimp contacts

silver plated

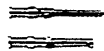

0.14-0.37  
0.5  
0.75  
1.0  
1.5  
2.5

0.14-0.37	09 15 000 6104	09 15 000 6204
0.5	09 15 000 6103	09 15 000 6203
0.75	09 15 000 6105	09 15 000 6205
1.0	09 15 000 6102	09 15 000 6202
1.5	09 15 000 6101	09 15 000 6201
2.5	09 15 000 6106	09 15 000 6206

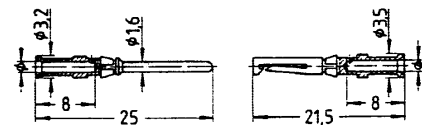

gold plated

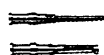

0.14-0.37  
0.5  
0.75  
1.0  
1.5  
2.5

0.14-0.37	09 15 000 6124	09 15 000 6224
0.5	09 15 000 6123	09 15 000 6223
0.75	09 15 000 6125	09 15 000 6225
1.0	09 15 000 6122	09 15 000 6222
1.5	09 15 000 6121	09 15 000 6221
2.5	09 15 000 6126	09 15 000 6226

Wire gauge		ø	Stripping length
0.14-0.37 mm²	AWG 26-22	0.90 mm	8 mm
0.5 mm²	AWG 20	1.10 mm	8 mm
0.75 mm²	AWG 18	1.30 mm	8 mm
1 mm²	AWG 18	1.45 mm	8 mm
1.5 mm²	AWG 16	1.75 mm	8 mm
2.5 mm²	AWG 14	2.25 mm	6 mm

FOC contacts

for 1 mm plastic fibre

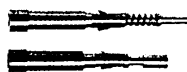

20 10 001 3211      20 10 001 3221

Cable see catalogue  
"Fibre Optic Data Link Systems"

## Features

- 4 contact chambers for
  - Coaxial contacts
  - FOC contacts
  - High voltage contacts
  
- Male insert with additional protection collar
  
- Polarization of module

## Technical characteristics

Specifications DIN VDE 0627  
DIN VDE 0110

### Approvals

### Inserts

Number of contacts	4
Pollution degree	3 (C)
Material	Polycarbonate
Insulation resistance	$\geq 10^{10} \Omega$
Temperature range	- 40 °C + 125 °C
Flammability acc. to UL 94	V0
Mechanical working life	$\geq 500$
- mating cycles	

### Contacts

Coaxial contact	
- Material	copper alloy
- Contact surface	hard-gold plated
	2.5 $\mu\text{m}$ / 0.8 $\mu\text{m}$ Au over 4 $\mu\text{m}$ Ni
- Impedance	50 $\Omega$
- Contact resistance	
centre conductor	$\leq 10 \text{ m}\Omega$
outer conductor	$\leq 3 \text{ m}\Omega$
- max. working current	1.5 A
- Working voltage	50 V ~

High voltage	
- Material	copper alloy
- Contact surface	hard-gold plated
	1.3 $\mu\text{m}$ Au over 4 $\mu\text{m}$ Ni
- Contact resistance	max. 3.0 $\text{m}\Omega$
- Max. working current	1.5 A
- Working voltage	1000 V ~

FOC contact <sup>2)</sup>	
- Fibre type	glass fibre (GI)
- Attenuation	< 1.5 dB

FOC contact <sup>2)</sup>	
- Fibre type	polymer optical fibre
- Attenuation	< 2.5 dB

### Contact arrangement

according to table below:

Contacts	Male insert (M) 09 14 004 4501	Female insert (F) <sup>1)</sup> 09 14 004 4512
Coaxial contacts	Female contacts	Male contacts
High voltage contacts	Female contacts	Male contacts
FOC contacts	Male contacts	Female contacts

### Coaxial contacts

usable for the cables listed below:

Cable group 2 flexible wires	Shell $\varnothing$ mm	Screening $\varnothing$ mm	Dielectric $\varnothing$ mm	Internal wire $\varnothing$ mm	Hexagonal crimp Spanner width
RG 174 / U	2.5	2.0	1.5	0.48	3.25
RG 188 A / U	2.6	2.0	1.5	0.54	3.25
RG 316 / U	2.5	2.0	1.5	0.54	3.25

Stripping description:

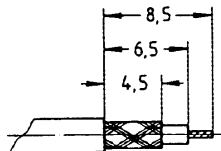

06  
18

<sup>1)</sup> Due to the closed entry design of female insert the upper part has to be removed by screw driver (7 mm) before extracting the contacts

<sup>2)</sup> See catalogue „Fibre Optic Data Link Systems“



Number of contacts

# 4



## Han® Multicontact-module

Identification	Part No.		Drawing	Dimensions in mm
	Male insert (M)	Female insert (F)		
Multicontact-module				
Order contacts separately	09 14 004 4501		M	
		09 14 004 4512	F	

Identification	Part No.		Drawing	Dimensions in mm
	Male contacts	Female contacts		
Coaxial contacts <sup>1)</sup> for straight solder and/or crimp terminations	09 03 000 6160	09 03 000 6260		
			For cable group 2 flexible wires (see remarks on page 06.18)	

Identification	Part No.		Drawing	Dimensions in mm
	Male contacts	Female contacts		
High voltage contacts <sup>1)</sup> for straight solder terminations 1000 V	09 03 000 6140	09 03 000 6240		
			wire gauge max. 0.5 mm <sup>2</sup>	

Identification	Part No.		Drawing	Dimensions in mm
	Male contacts	Female contacts		
FOC contacts according to DIN 41 626 part 3 <sup>1)</sup> for GI-fibre 50/125 μm 62.5/125 μm	on request	on request		

for 1 mm POF<sup>2)</sup>

<sup>1)</sup> See contact arrangement page 06.18

<sup>2)</sup> POF = Polymer Optical Fibre



## Features

- 3 contacts for transmission of gaseous and liquid media
- Termination of 1.6 mm, 3 mm and 4 mm ID-tubes
- Tubing sizes in module mixable
- Stable plastic construction of contacts
- Removal of tubes from already assembled pneumatic contacts is possible
- Female contacts with/without shut off
- Shut off principle:  
 In open position of connector the spring integrated in female contact is active, thus the O-ring of valve seals the opening of passage.  
 During the mating step, when the defined depth of immersion is reached, the male contact presses on the valve head and moves it to the termination side against the spring tension, so that the passage opens.

## Technical characteristics

### Specifications

### Approvals

### Inserts

Number of contacts	3
Colour	blue
Material	Polycarbonate
Temperature range	- 40 °C + 80 °C
Flammability acc. to UL 94	V 0
Mechanical working life - mating cycles	≥ 500

### Contacts

Material	Delrin Acetal
Colour	black
Tube termination - Internal diameter (ID):	1.6 mm / 1/16" 3.0 mm 4.0 mm / 1/8"
Working pressure	vacuum up to 8 bar / 116 psi

### Sealing

Material	Buna-N
----------	--------

### Shut off valve

Material	Polypropylene
----------	---------------

Number of contacts

# 3



## Han® Pneumatic-module

Identification	Part No.		Drawing	Dimensions in mm
	Male insert (M)	Female insert (F)		
Pneumatic-module <sup>1)</sup> Order contacts separately (male and female inserts are identical)	09 14 003 4501	09 14 003 4501		

Identification	Part No.		Drawing	Dimensions in mm
	Male contacts	Female contacts		
Contacts without shut off <sup>1)</sup>  for tube internal diameter				
1.6 mm	09 14 000 6151	09 14 000 6251		Contact arrangement View form mating side
3.0 mm	09 14 000 6152	09 14 000 6252		
4.0 mm	09 14 000 6153	09 14 000 6253		

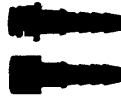

### Contacts with shut off<sup>1)</sup>

for tube internal diameter	Male contacts	Female contacts
1.6 mm	—	09 14 000 6256
3.0 mm	—	09 14 000 6257
4.0 mm	—	09 14 000 6258



shut off principle: see page 06.20

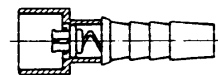

female contact with shut off in closed position

<sup>1)</sup> Assembly of contacts before module is fixed into the frame

The integration of several electrical wires with different gauges; optical control lines and/or air tubes in one connector

## Protective tube

- Single wires have more space to move
- Ideal for short-run production
- Easy maintenance/service

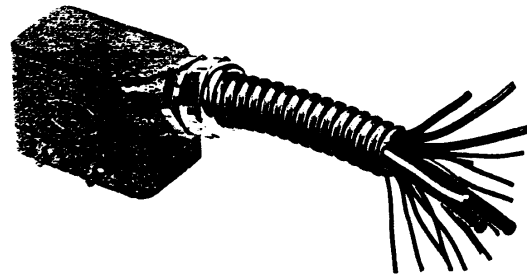

## Special cable

- Optimal solution for large-scale production
- Professional design

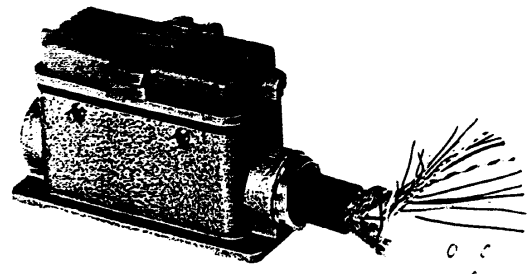

## Hood with several cable entries (see page 06.34)

- Single wires are less expensive than special wires
- Easy maintenance/service

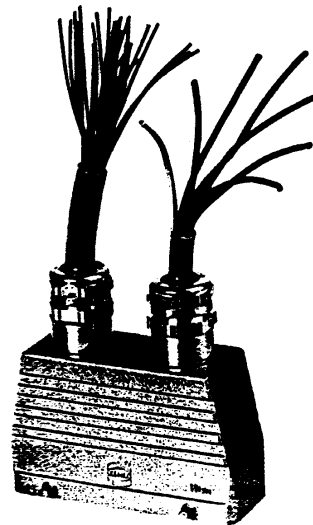

## Cable sealing with several cable inlets

- Ideal for wires/tubes with approximately similar wire gauges
- Easy maintenance/service

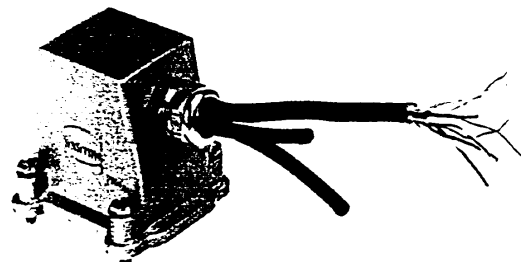

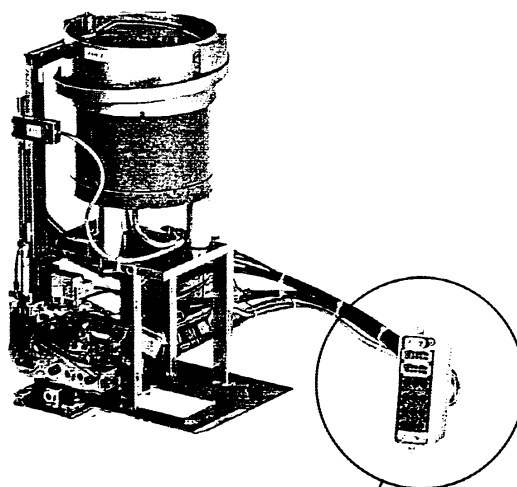
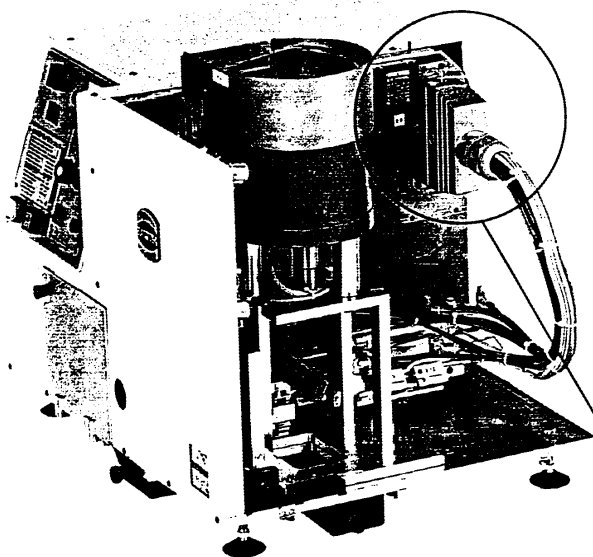

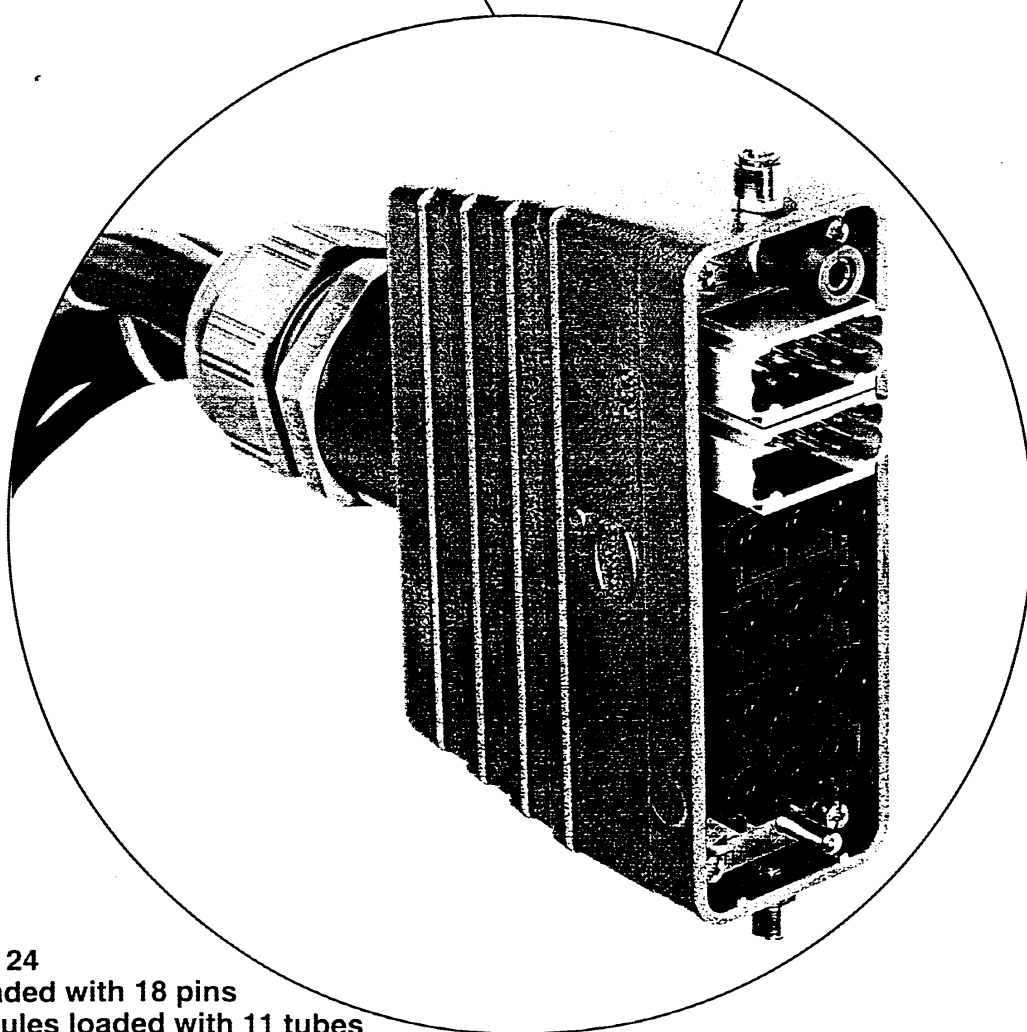

Automatic Crimping Machine TK  
with change unit -E- and change unit -D-  
connected with **Han-Modular®**



- Han-Modular® size 24**
- 2 DD modules loaded with 18 pins
  - 4 Pneumatic modules loaded with 11 tubes



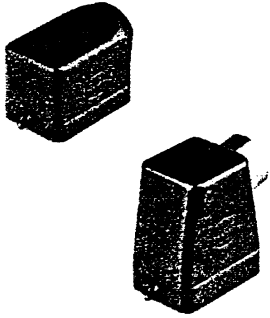
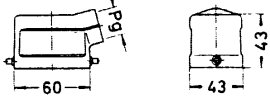
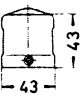
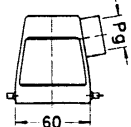
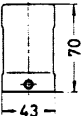
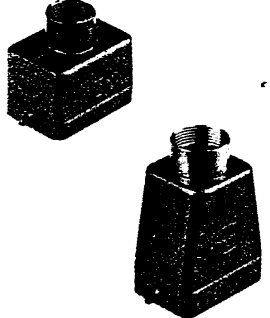
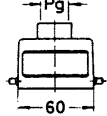

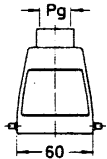
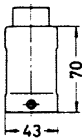
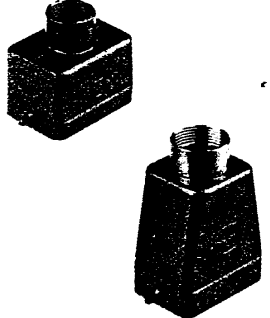
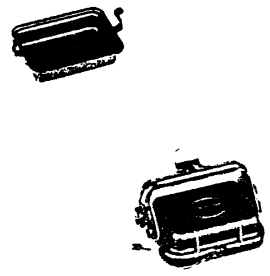
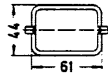
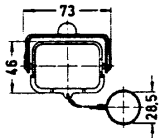





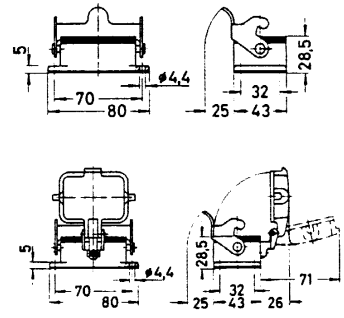

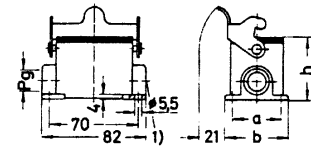

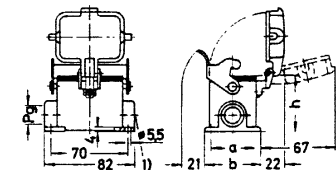

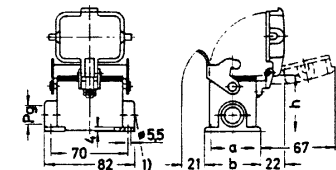

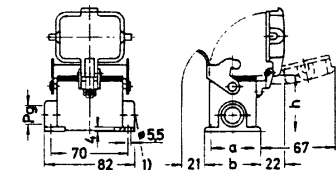

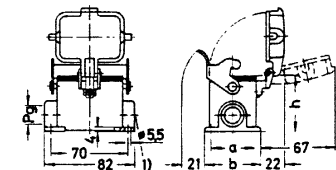

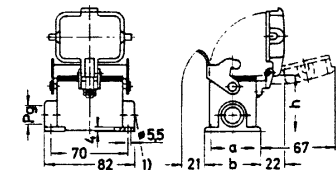

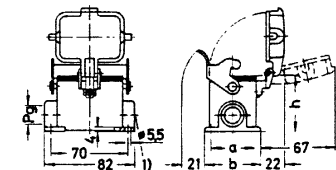
# Standard Hoods/Housings with 1 lever on the housing for 2 modules

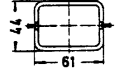

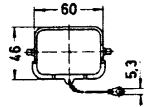
Identification	Part No.		Pg	Drawing	Dimensions in mm	
	Low construction	High construction				
<b>Hoods side-entry</b> 	09 30 006 1540		13.5			
	09 30 006 1541		16			
		09 30 006 0542		21		
		09 30 006 0543		29		
	<b>Hoods top-entry</b> 	09 30 006 1440		13.5		
		09 30 006 1441		16		
		09 30 006 0442		21		
		09 30 006 0443		29		
<b>Hoods</b> 						
<b>Protection covers metal</b> 	09 30 006 5401					
	09 30 006 5423					

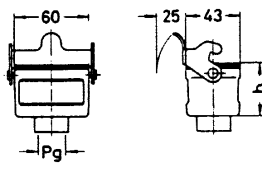
# Standard Hoods/Housings with 1 lever on the housing for 2 modules

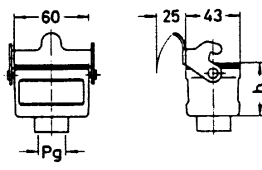

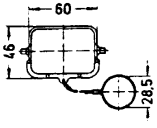









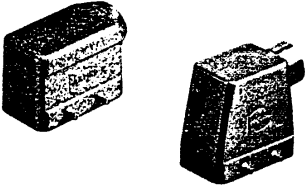
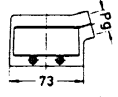

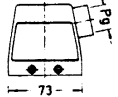

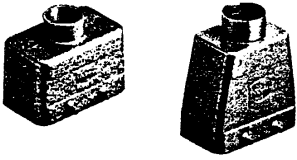
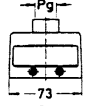

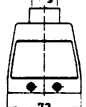

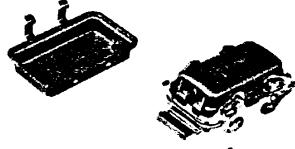
Identification	Part No.		Pg	Drawing	Dimensions in mm												
	Low construction	High construction															
<b>Housings bulkhead mounting</b>																	
	09 30 006 0301				Panel cut out 48 x 35 cm												
	with thermo-plastic cover																
	09 30 006 0302																
	with metal cover																
	09 30 006 0318																
<b>Housings surface mounting</b>																	
	1 side-entry	09 30 006 1251	16														
	2 side-entry	09 30 006 1291															
	2 side-entry	09 30 006 1292	16 21														
	with thermo-plastic cover																
	1 side-entry	09 30 006 1256	16														
	with metal cover																
	2 side-entry	09 30 006 2256	16														
	with thermo-plastic cover																
	2 side-entry	09 30 006 1296	16 21														
	with thermo-plastic cover																
	2 side-entry	09 30 006 2296	16 21														
	with metal cover																
	2 side-entry	09 30 006 2297	16 21														
	with metal cover																
1) Blind way for one cable entry <table border="1" data-bbox="1104 1186 1356 1260"> <thead> <tr> <th></th> <th>a</th> <th>b</th> <th>h</th> </tr> </thead> <tbody> <tr> <td>Low construction</td> <td>40</td> <td>52</td> <td>54</td> </tr> <tr> <td>High construction</td> <td>45</td> <td>57</td> <td>74</td> </tr> </tbody> </table>							a	b	h	Low construction	40	52	54	High construction	45	57	74
	a	b	h														
Low construction	40	52	54														
High construction	45	57	74														
<b>Protection covers metal</b>																	
	09 30 006 5404																
	09 30 006 5425																
	09 30 006 5425																
<b>Hoods cable to cable</b>																	
	09 30 006 1750		16 21														
		09 30 006 0752	16 21														
<b>Protection cover metal</b>																	
	09 30 006 5427																

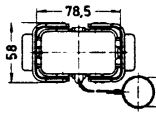
For further selection of hoods/housings see catalogue Heavy Duty Connectors

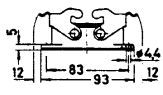
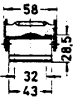
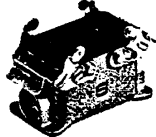
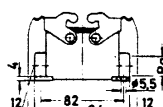
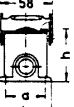
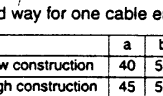

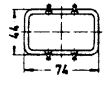
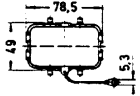
# Standard Hoods/Housings with 2 levers on the housing for 3 modules

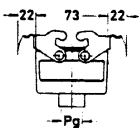
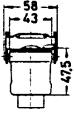

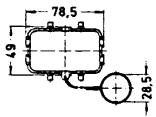
Identification	Part No.		Pg	Drawing	Dimensions in mm	
	Low construction	High construction				
<b>Hoods side-entry</b> 	09 30 010 1521		16			
		09 30 010 0522	21			
		09 30 010 0523	29			
<b>Hoods top-entry</b> 	09 30 010 1421		16			
		09 30 010 0422	21			
		09 30 010 0423	29			
<b>Protection covers metal</b> 	09 30 010 5401					
	09 30 010 5423					
<b>Housing bulkhead mounting</b> 	09 30 010 0301					
<b>Housings surface mounting</b> 	1 side-entry	09 30 010 1231				
			09 30 010 0232	16		
	2 side-entry	09 30 010 1271				
			09 30 010 0272	16		
		09 30 010 0273	21			
			29			
<b>Protection covers metal</b> 	09 30 010 5407					
	09 30 010 5425					
<b>Hood cable to cable</b> 	09 30 010 1731		16			
<b>Protection cover metal</b> 	09 30 010 5427					

Panel cut out 60 x 35











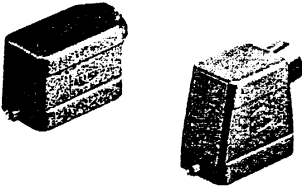
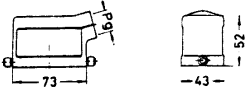

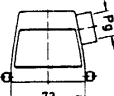
Blind way for one cable entry

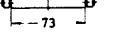
	a	b	h
Low construction	40	52	54
High construction	45	57	74

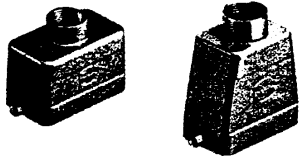

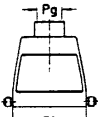
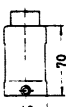
# Standard Hoods/Housings with 1 lever on the housing for 3 modules

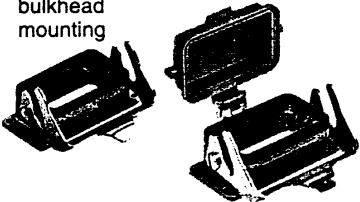
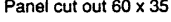
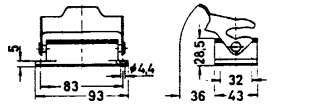
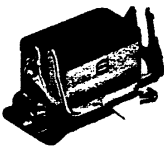
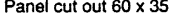
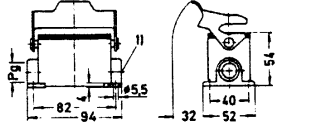
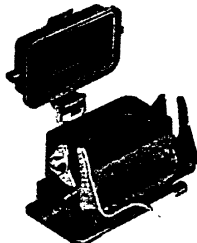

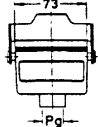
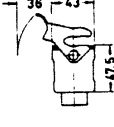
Identification	Part No.		Pg	Drawing	Dimensions in mm
	Low construction	High construction			
Hoods side-entry		09 30 010 1541	16		
		09 30 010 0542	21		
		09 30 010 0543	29		
Hoods top-entry		09 30 010 1441	16		
		09 30 010 0442	21		
		09 30 010 0443	29		
Housings bulkhead mounting		09 30 010 0305			
		09 30 010 0303 with thermo- plastic cover			
Housings surface mounting		1 side-entry 09 30 010 1251	16		
		2 side-entry 09 30 010 1291	16		
		1 side-entry 09 30 010 1256 with thermo- plastic cover	16		
		2 side-entry 09 30 010 1296 with thermo- plastic cover	16		
		2 side-entry 09 30 010 2296 with metal cover	16		
Hood cable to cable		09 30 010 1751	16		







Panel cut out 60 x 35

<sup>1)</sup> Blind way for one cable entry

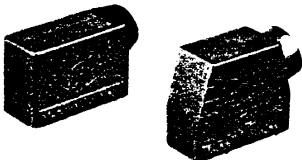
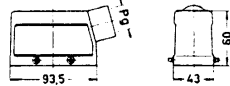
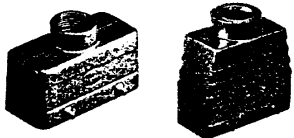
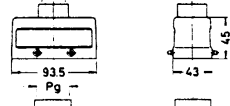
For further selection of hoods/housings see catalogue Heavy Duty Connectors Han-Com®

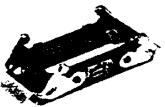
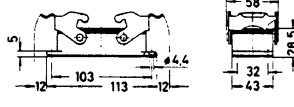
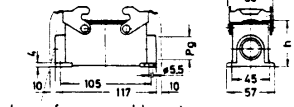
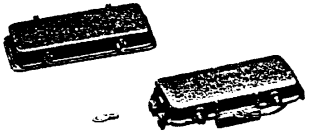
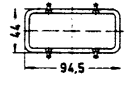

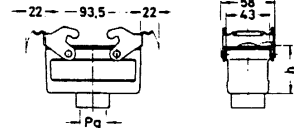

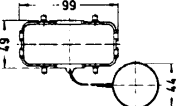







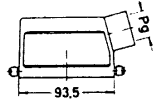

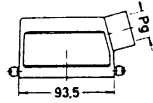

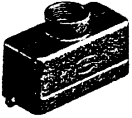

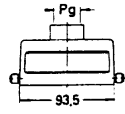

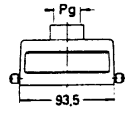
# Standard Hoods/Housings with 2 levers on the housing for 4 modules

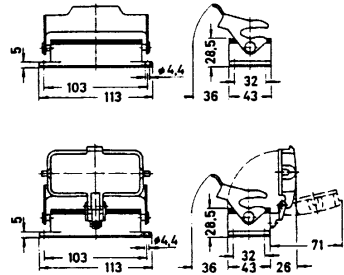
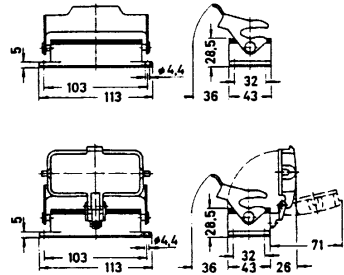
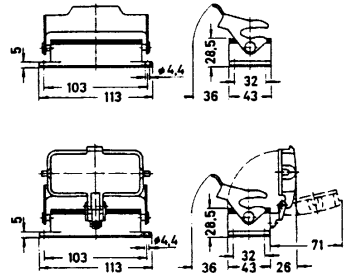

Identification	Part No.		Pg	Drawing	Dimensions in mm
	Low construction	High construction			
Hoods side-entry		09 30 016 1520	21		
		09 30 016 0520 09 30 016 0521	21 29		
Hoods top-entry		09 30 016 1420	21		
		09 30 016 0420 09 30 016 0421	21 29		
Protection covers metal		09 30 016 5401			
		09 30 016 5422			
Housing bulkhead mounting		09 30 016 0301			
Housings surface mounting	1 side-entry	09 30 016 1230	09 30 016 0230 09 30 016 0231	21 29	
	2 side-entry	09 30 016 1270	09 30 016 0270 09 30 016 0271	21 29	
Protection covers metal		09 30 016 5405			
		09 30 016 5425			
Hoods cable to cable		09 30 016 1730	09 30 016 0730 09 30 016 0731	21 21 29	
Protection cover metal		09 30 016 5426			

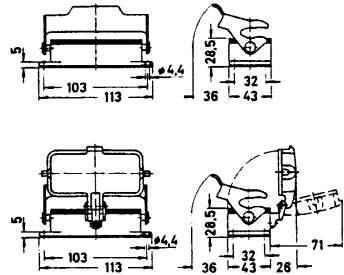
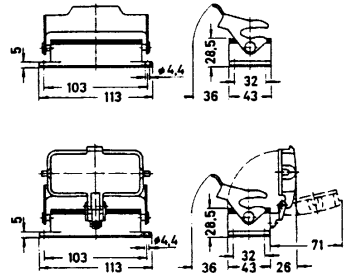
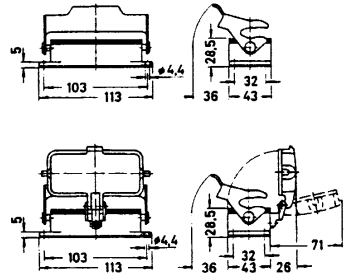
# Standard Hoods/Housings with 1 lever on the housing for 4 modules

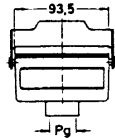
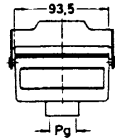

Identification	Part No.		Pg	Drawing	Dimensions in mm
	Low construction	High construction			
Hoods side-entry	 	09 30 016 1540	21	 	 
		09 30 016 0540 09 30 016 0541	21 29		
Hoods top-entry	 	09 30 016 1440	21	 	 
		09 30 016 0440 09 30 016 0441	21 29		
Housings bulkhead mounting	 	09 30 016 0307	21		 
		with thermo-plastic cover 09 30 016 0306			
		with metal cover 09 30 016 0318			
Housings surface mounting		1 side-entry 09 30 016 1250	21		 
		2 side-entry 09 30 016 1290	21		
		1 side-entry 09 30 016 1255	21		
		2 side-entry 09 30 016 1295	21		
		2 side-entry with thermo-plastic cover 09 30 016 2295	21		
		2 side-entry with metal cover 09 30 016 2295	21		
Hood cable to cable		09 30 016 1750	21	 	

For further selection of hoods/housings see catalogue Heavy Duty Connectors Han-Com®

# Standard Hoods/Housings with 2 levers on the housing for 6 modules



Identification	Part No.		Pg	Drawing	Dimensions in mm
	Low construction	High construction			
Hoods side-entry	09 30 024 1520		21		
		09 30 024 0520 09 30 024 0521	21 29		
Hoods top-entry	09 30 024 1421		29		
		09 30 024 0420 09 30 024 0421	21 29		
Protection covers metal	09 30 024 5401				
	09 30 024 5422				
Housings bulkhead mounting	09 30 024 0301				
Housings surface mounting	1 side-entry	09 30 024 1230	09 30 024 0230 09 30 024 0231	21 29	
	2 side-entry	09 30 024 1270	09 30 024 0270 09 30 024 0271	21 29	
Protection covers metal	09 30 024 5405				
	09 30 024 5425				
Hoods cable to cable	09 30 024 1731		21		
		09 30 024 0730 09 30 024 0731	21 29		
Protection cover metal	09 30 024 5426				

# Standard Hoods/Housings with 1 lever on the housing for 6 modules



Identification	Part No.		Pg	Drawing	Dimensions in mm	
	Low construction	High construction				
Hoods side-entry	09 30 024 1540		21			
		09 30 024 0540 09 30 024 0541	21 29			
Hoods top-entry	09 30 024 1441		29			
		09 30 024 0440 09 30 024 0441	21 29			
Housings bulkhead mounting	09 30 024 0307					
		with thermo- plastic cover 09 30 024 0304				
		with metal cover 09 30 024 0318				
Housings surface mounting	1 side-entry 09 30 024 1250		21			
	2 side-entry 09 30 024 1290		21			
		with thermo- plastic cover 09 30 024 1255		21		
		with thermo- plastic cover 09 30 024 1295	with thermo- plastic cover 09 30 024 0295 09 30 024 0296	21 29		
		2 side-entry with metal cover 09 30 024 2295		21		
Hood cable to cable	09 30 024 1751		29			

Panel cut out 108 x 35 mm

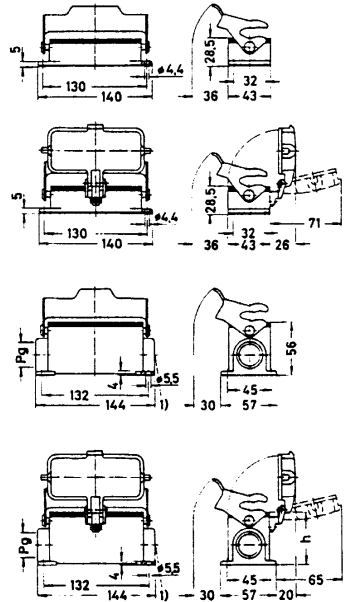

<sup>1)</sup> Blind way for one cable entry

	h
Low construction	56
High construction	80

For further selection of hoods/housings see catalogue Heavy Duty Connectors Han-Com®

# Standard Housings with 2 levers on the housing for 8 modules



Identification	Size	Part No.	Pg	Drawing	Dimensions in mm
Hoods side-entry	32	09 30 032 0521	29		94 82,5
	32	09 30 032 0522	36		
	32	09 30 032 0523	42		
Hoods top-entry	32	09 30 032 0421	29		94 82,5
	32	09 30 032 0422	36		
Housing bulkhead mounting	32	09 30 032 0301	-		
Housings surface mounting	1 side-entry	32	09 30 032 0231	29	
		32	09 30 032 0232	36	
	2 side-entry	32	09 30 032 0271	29	
		32	09 30 032 0272	36	
Hood cable to cable	32	09 30 032 0732	36		



Identification	Size	Part No.	Pg	Drawing	Dimensions in mm			
Hoods side-entry	48	09 30 048 0540	29					
	48	09 30 048 0541	36					
	48	09 30 048 0542	42					
Hoods top-entry	48	09 30 048 0440	29					
	48	09 30 048 0441	36					
	48	09 30 048 0442	42					
Housings bulkhead mounting	48	with thermo- plastic cover 09 30 048 0301						
	48	with metal cover 09 30 048 0317						
Housings surface mounting 2 side-entry	48	09 30 048 0290	29					
	48		09 30 048 0291			36		
	48	with thermo- plastic cover 09 30 048 0295	29					
	48		09 30 048 0296			36		
						Panel cut out		
						Blind way		

# Hoods for Special Applications



Identification

Hoods  
top entry



Size

Part No.

Pg

Drawing

Dimensions in mm

10	09 30 010 0460	2x13.5
16	09 30 016 0459	2 x 16
16	09 30 016 0462	2 x 21
24	09 30 024 0462	2 x 21
24	09 30 024 0461	2 x 29

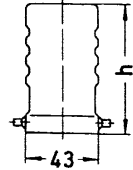
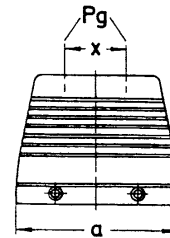

Size	a	h	x	Pg
10	73	72	20	2x13.5
16	93.5	76	36	2x16
16	93.5	76	36	2x21
24	120	76	52	2x21
24	120	76	48	2x29

Hoods  
angled entry

Hoods

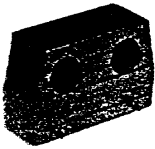

16	09 30 016 0663	2 x 21
24	09 30 024 0663	2 x 21

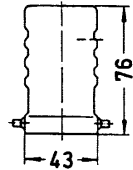
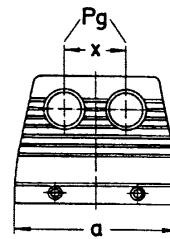

Size	a	x	Pg
16	93.5	36	2 x 21
24	120	56	2 x 21

Hoods  
without entries  
for customer drillings

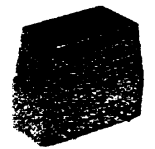

6	09 30 006 0801	
10	09 30 010 0801	
16	09 30 016 0801	
24	09 30 024 0801	

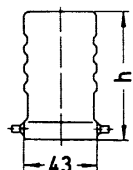
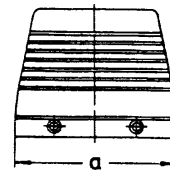
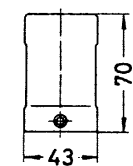
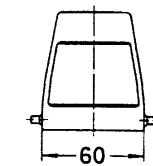

Size	a	h
10	73	72
16	93.5	76
24	120	76

Housings

Housings

6	Page 06.25
10	Page 06.26
16	Page 06.28
24	Page 06.30



Identification

Part No.

Pg

Drawing

Dimensions in mm

Universal cable protection  
metal



09 00 000 5083  
09 00 000 5084  
09 00 000 5085

13.5  
13.5  
13.5

SW	D	
	min.	max.
22	6.5	9.5
22	7	10.5
22	9	13

09 00 000 5086  
09 00 000 5087  
09 00 000 5088  
09 00 000 5089

16  
16  
16  
16

24	6.5	9.5
24	7	10.5
24	9	13
24	11.5	15.5

09 00 000 5090  
09 00 000 5091  
09 00 000 5092  
09 00 000 5093

21  
21  
21  
21

30	7	10.5
30	9	13
30	11.5	15.5
30	14	18

09 00 000 5094  
09 00 000 5095  
09 00 000 5096  
09 00 000 5097

29  
29  
29  
29

40	14	18
40	17	21
40	20	25
40	24	28

09 00 000 5098  
09 00 000 5099

36  
36

50	29	34
50	32	36

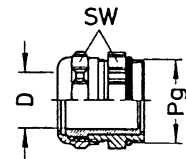

Cable sealing metal  
with normal seal  
for Standard Hoods/Housings



09 00 000 5114  
09 00 000 5115  
09 00 000 5116  
09 00 000 5117  
09 00 000 5146  
09 00 000 5119

13.5  
16  
21  
29  
36  
42

SW	ø
20	13
22	15
28	20
37	29
47	36
54	42

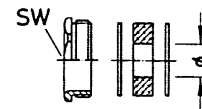

Cable sealing metal  
with multiple seal  
for Standard Hoods/Housings



09 00 000 5014  
09 00 000 5015  
09 00 000 5016  
09 00 000 5017  
09 00 000 5018  
09 00 000 5019

13.5  
16  
21  
29  
36  
42

SW	min.	ø	max.
20	7.5	12.5	
22	7.5	15	
28	10	19	
37	18	27	
47	24	33	
54	30	39	

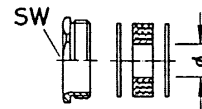

Protective tube sealing

metal on request

plastic on request

Coding system with code bushes

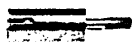

09 14 000 9901<sup>1)</sup>

for hoods/housings with one frame

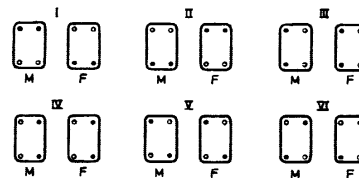

for hoods/housings with two frames

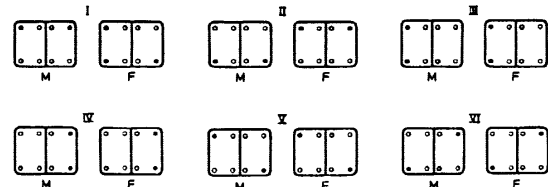

● Code bushes  
○ Normal mounting screw

M - Male connector  
F - Female connector

<sup>1)</sup> Order 4 pieces for one connector

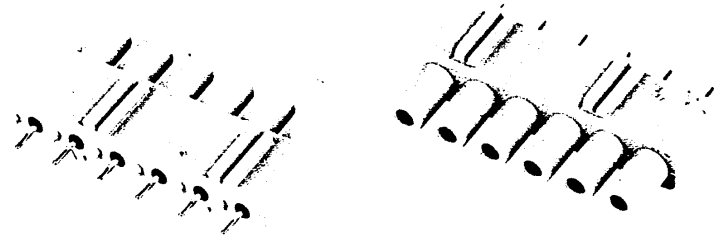

Han pcb-adapter

Identification

Part No.

Drawing

Dimensions in mm

Adapter (contacts included)  
 can be used in combination with:  
 Han DD-Module  
 Han K 8 / 24  
 Han K 6 / 36  
 Han DD

0916 000 9905

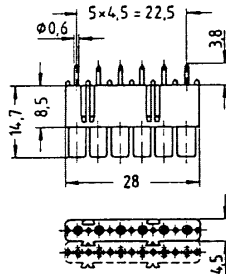

Han DD adapter contacts  
 male contacts

09 15 000 6191

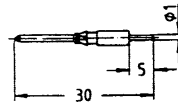

female contacts

09 15 000 6291

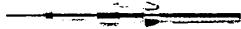
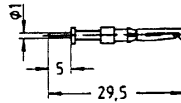

Application

The pcb-adapter is used to terminate control and data lines via pcb to the above mentioned connector inserts.

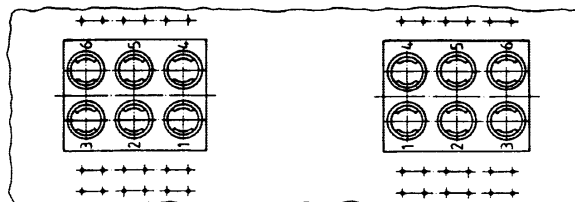
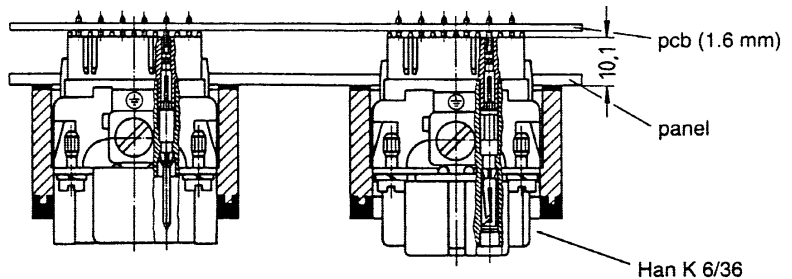

# Summary Han Crimping tools



Identification	mm <sup>2</sup>	AWG	Part No.										Contact removal tool										
			Crimping tool					Crimping tool depth adjustment gauge															
Series			09 99 000 0001	09 99 000 0110	09 99 000 0300	09 99 000 0303	09 99 000 0307	09 99 000 0314	Automatic crimping machine TK	09 99 000 0194	20 99 000 1032	20 99 000 1033	09 99 000 0006	09 99 000 0007	09 99 000 0008	09 99 000 0009	09 99 000 0125	09 99 000 0203	20 99 001 1032	20 99 002 1032			
Han C-module Power contacts Han C 09 32 ... .. 	1.5	16	x				x	x								x						09 99 000 0305	
	2.5	14	x				x	x								x							
	4.0	12	x			x	x	x			x												
	6.0	10				x	x									x							
Han DD-module Signal contacts Han D 09 15 ... .. 	0.14	26	x <sup>3)</sup>	x	x			x <sup>3)</sup>											x <sup>3)</sup>			09 99 000 0012 09 99 000 0052	
	0.25	24	x <sup>3)</sup>	x	x			x <sup>3)</sup>											x				
	0.37	22	x	x	x			x	x										x				
	0.5	20	x	x	x			x	x						x								
	0.75	18	x	x	x			x	x						x								
	1.0	18	x	x	x			x	x						x								
	1.5	16	x	x	x			x	x							x							
	2.5	14	x					x	x							x							
Han E-module Power contacts Han E 09 33 ... .. 	0.5	20	x	x	x			x	x						x							09 99 000 0319	
	0.75	18	x	x	x			x	x						x								
	1.0	18	x	x	x			x	x						x								
	1.5	16	x	x	x			x	x							x							
	2.5	14	x	x	x			x	x							x							
Multicontact-module Coaxial contacts												x										09 99 000 0174 <sup>1)</sup> 09 99 000 0320 <sup>1)</sup>	
	FOC contacts, POF (DIN 41 626)											x <sup>1)</sup> x <sup>1)</sup>											

Identification	Part No.																					
Locator Han C	09 99 000 0308	x						x	x													
	09 99 000 0304							x														
Han D	09 99 000 0311	x																				
	09 99 000 0301																					
Han E	09 99 000 0111																					
	09 99 000 0310	x																				
	09 99 000 0302																					
FOC contacts (DIN 41 626)	20 99 000 1036																					

1) both tools are necessary  
 2) to adjust female contact, only  
 3) for wire gauge 0.14 mm<sup>2</sup> and 0.25 mm<sup>2</sup> use only male contact 09 15 000 6107 respectively female contact 09 15 000 6207

# Crimping tools Power contacts (Han C 09 32 . . .)



Identification Part No. Drawing Dimensions in mm

BUCHANAN-crimping tool

09 99 000 0001

Wire gauge  
1.5 - 4 mm<sup>2</sup>

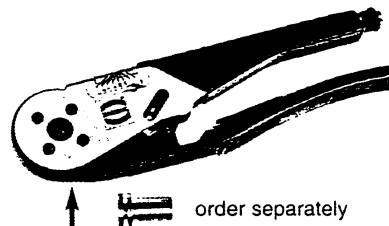

Locator

09 99 000 0308

Crimping tool depth adjustment gauge

09 99 000 0008  
09 99 000 0006

Wire gauge  
1.5 + 2.5 mm<sup>2</sup> ø 1.80  
4 mm<sup>2</sup> ø 2.00

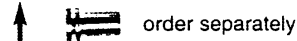

HARTING-crimping tool

09 99 000 0303

Wire gauge  
4 - 6 mm<sup>2</sup>



Locator as spare part

09 99 000 0304

Locator is supplied with the tool

HARTING-pneumatic crimping tool

09 99 000 0307

Crimping tool depth adjustment gauge

09 99 000 0008  
09 99 000 0006  
09 99 000 0009

Wire gauge  
1.5 + 2.5 mm<sup>2</sup> ø 1.80  
4 mm<sup>2</sup> ø 2.00  
6 mm<sup>2</sup> ø 2.40

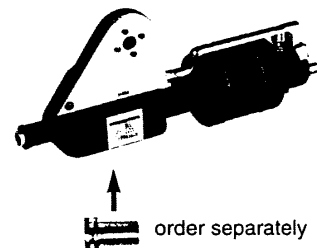

Locator

09 99 000 0308

Table fixing and foot switch for pneumatic crimping tool

09 99 000 0309



Removal tool for crimp contacts

Removal tool

09 99 000 0305









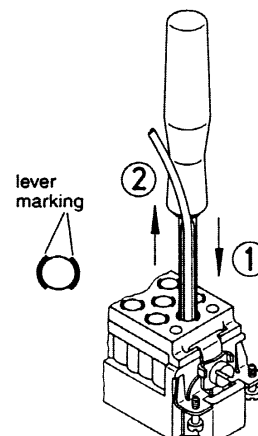







A removal tool is necessary to remove the contacts.

For each „C“ contact cavity, the location of the internal locking levers are marked on the wiring side with two black arcs. The sides of the tool must be first properly aligned thus edges of the tool catch both levers simultaneously and then inserted until a stop is noticeable ①.

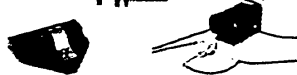
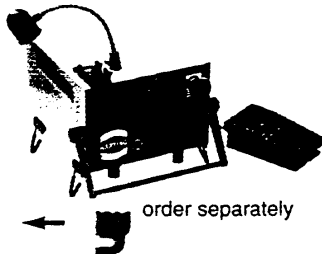
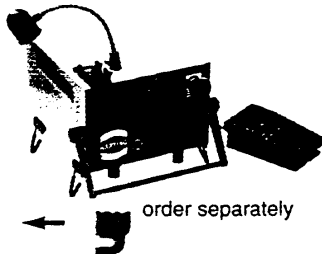















Once it has been inserted, the tool **must not** be turned. The wire together with the tool can then be pulled out from the wiring side of the insert ②.

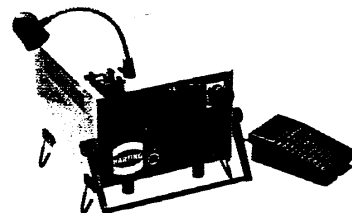

Identification	Part No.	Drawing	Dimensions in mm
HARTING-crimping tool	09 99 000 0110	Wire gauge 0.14 - 1.5 mm <sup>2</sup>	
Locator	09 99 000 0111		 order separately
HARTING-crimping tool	09 99 000 0300	Wire gauge 0.14 - 1.5 mm <sup>2</sup>	
Locator as spare part	09 99 000 0301	Locator is supplied with the tool	
BUCHANAN-crimping tool	09 99 000 0001	Wire gauge 0.37 - 2.5 mm <sup>2</sup>	
Locator	09 99 000 0311		 order separately
Crimping tool depth adjustment gauge	09 99 000 0125	Wire gauge 0.37 mm <sup>2</sup> ø 1.30	
	09 99 000 0007	0.5-1 + 2.5 mm <sup>2</sup> ø 1.55	
	09 99 000 0008	1.5 mm <sup>2</sup> ø 1.80	
For FOC contact: Crimping tool	20 99 000 1032		
Crimping tool depth adjustment gauge	20 99 001 1032	ø 1.45	
HARTING-pneumatic crimping tool	09 99 000 0314		
Locator	09 99 000 0311		 order separately
Crimping tool depth adjustment gauge	09 99 000 0125	Wire gauge 0.37 mm <sup>2</sup> ø 1.30	
	09 99 000 0007	0.5-1 + 2.5 mm <sup>2</sup> ø 1.55	
	09 99 000 0008	1.5 mm <sup>2</sup> ø 1.80	
Table fixing and foot switch for pneumatic crimping tool	09 99 000 0309		
HARTING-semi-automatic crimping device			
Main drive foot-operated 220 V/50 Hz	09 99 000 0246		
Crimping head	09 99 000 0254	Wire gauge 0.14 - 1.5 mm <sup>2</sup>	
Locator	09 99 000 0111		
Insertion tool for crimp contacts	09 99 000 0059		
Removal tool for crimp contacts (also for FOC contact)			 .. 0012
Removal tool	09 99 000 0012		 .. 0004
Replacement-tip of removal tool	09 99 000 0004		 .. 0052
Removal tool	09 99 000 0052		

For crimp contacts with wires of less than 0.75 mm<sup>2</sup> it is recommended that an insertion tool is used. Contacts should be inserted from the wiring side and pushed down until a positive locking is achieved.

A removal tool is necessary if contacts are to be replaced in the insert. It is inserted from the mating face and pushed over the contact until a stop is noticeable. Additional pressure unlocks the contact and pushes it out of the wiring side. In case of the removal tool (. . 0052) the unlocking process is achieved by pressure on the central rod.

Identification	Part No.	Drawing	Dimensions in mm
HARTING-crimping tool	09 99 000 0110	Wire gauge 0.5 - 2.5 mm <sup>2</sup>	
Locator	09 99 000 0112		 order separately
HARTING-crimping tool	09 99 000 0300	Wire gauge 0.5 - 2.5 mm <sup>2</sup>	
Locator as spare part	09 99 000 0302	Locator is supplied with the tool	
BUCHANAN-crimping tool	09 99 000 0001	Wire gauge 0.5 - 4 mm <sup>2</sup>	
Locator	09 99 000 0310		 order separately
Crimping tool depth adjustment gauge	09 99 000 0007 09 99 000 0008 09 99 000 0006	Wire gauge 0.5 - 1 mm <sup>2</sup> ø 1.55 1.5 - 2.5 mm <sup>2</sup> ø 1.80 4 mm <sup>2</sup> ø 2.00	 order separately
HARTING-pneumatic crimping tool	09 99 000 0314		
Locator	09 99 000 0310		 order separately
Crimping tool depth adjustment gauge	09 99 000 0007 09 99 000 0008 09 99 000 0006	Wire gauge 0.5 - 1 mm <sup>2</sup> ø 1.55 1.5 - 2.5 mm <sup>2</sup> ø 1.80 4 mm <sup>2</sup> ø 2.00	 order separately
Table fixing and foot switch for pneumatic crimping tool	09 99 000 0309		
HARTING-semi-automatic crimping device	09 99 000 0246		
Main-drive foot-operated 220 V/50 Hz	09 99 000 0246		
Crimping head	09 99 000 0254	Wire gauge 0.5 - 2.5 mm <sup>2</sup>	 order separately
Locator	09 99 000 0112		 order separately
Insertion tool for crimp contacts	09 99 000 0059		
		For crimp contacts wires of less than 0.75 mm <sup>2</sup> it is recommended that an insertion tool is used. Contacts should be inserted from the wiring side and pushed down until a positive locking is achieved.	
Crimp contact removal for Han E-module	09 99 000 0319		
		A removal tool is necessary if contacts are to be replaced in the insert. The tool is inserted from the wiring side until a stop is noticeable(see page 06.15). The wire with the crimp contact can then be pulled out from the same side of the insert.	
Stripping tool	09 99 000 0159		
		For wires from 0.5 to 4.0 mm <sup>2</sup>	

Identification	Part No.	Drawing	Dimensions in mm
----------------	----------	---------	------------------

HARTING-  
automatic crimping machine TK  
- Power supply 230 V, 50 Hz  
- Compressed air connection 6 bar

09 98 000 6000

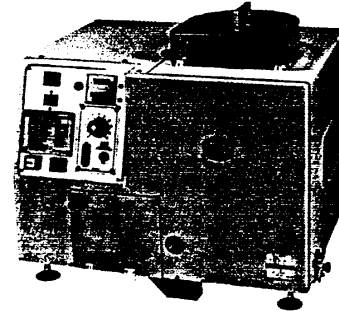

Change unit – E –  
for contacts 09 33 . . . .

09 98 000 6002

Crimping tool depth adjustment gauge

Part No.	Wire gauge
09 98 600 6331	0.5 - 1 mm <sup>2</sup> ø 1.55
09 98 600 6332	AWG 16 ø 1.60
09 98 600 6333	AWG 14 ø 1.70
09 98 600 6334	1.5 + 2.5 mm <sup>2</sup> ø 1.80
09 98 600 6335	3 + 4 mm <sup>2</sup> ø 2.00

Change unit – D –  
for contacts 09 15 . . . .

09 98 000 6001

Crimping tool depth adjustment gauge

Part No.	Wire gauge
09 98 600 6328	0.25 - 0.37 mm <sup>2</sup> ø 1.00
09 98 600 6329	0.37 mm <sup>2</sup> ø 1.30
09 98 600 6330	AWG 14 ø 1.45
09 98 600 6331	0.5-1 + 2.5 mm <sup>2</sup> ø 1.55
09 98 600 6332	AWG 16 ø 1.60
09 98 600 6334	1.5 mm <sup>2</sup> ø 1.80

# Crimping tools for contacts of Han Multicontact-module



Identification

Part No.

Drawing

Dimensions in mm

**HARTING-**  
crimping tool  
for coaxial contacts

09 99 000 0194



Use the middle crimping jaws

**BUCHANAN-**  
crimping tool  
for FOC contacts (1 mm POF)

20 99 000 1032

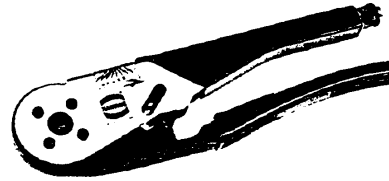

Crimping tool depth  
adjustment gauge  $\varnothing$  1.8 mm

20 99 002 1032

Note: This tool is only for FOC contacts

**HARTING-**  
crimping tool  
for FOC contacts (1 mm POF)  
width 3.0 mm

20 99 000 1033



Removal tool  
for contacts  
(see footnote on page 06.18)

09 99 000 0174



order separately



Removal jacket

09 99 000 0320



Removal tool  
for modules

09 99 000 0318

