

[Show navigation](#)**HARAX® circular connector****Technical characteristics**

Specifications IEC 60
352-4
IEC 60
9475-2

Approvals**HARAX® M8-S/M12-S**

Rated voltage	32 V
Rated current	4A
Conductor cross section	0,14 mm ² - 0,34 mm ² AWG 26 - 22
Diameter of individual strands	≥ 0.1 mm
Conductor insulation material	PVC / PP
Conductor diameter	M8-S: 1.0 mm - 1.6 mm M12-S: 1.0 - 1.6 mm
Cable diameter	M8-S: 3.2 - 5.4 mm M12-S: 4 mm - 5.1 mm
Temperature limits	- 25 °C ... + 85 °C
Temperature during connection	- 5 °C ... + 50 °C
Degree of protection	IP 67
Reconnection with the same cable cross section	10 times

HARAX® M12 angled

Working voltage	32 V
Working current	4A
Wire gauge	0,25 mm ² - 0,5 mm ² AWG 24/7 - 22
Diameter of individual strands	≥ 0.1 mm
Conductor insulation material	PVC
Conductor diameter	1.2 mm - 1.6 mm
Cable diameter	4 mm - 5.1 mm
Temperature limits	- 25 °C ... + 85 °C
Temperature during connection	- 5 °C ... + 50 °C
Degree of protection	IP 67
Reconnection with the same cable cross section	10 times

HARAX® M12-L

Rated voltage	50 V
---------------	------

Rated current	6 A
Conductor cross section	0.34 mm ² - 0.75 mm ² AWG 22 - 18
Diameter of individual strands	≥ 0.1 mm
Conductor insulation material	PVC
Conductor diameter	1.6 mm - 2.0 mm
Cable diameter	5.5 mm - 8 mm
Temperature limits	- 25 °C ... + 85 °C
Temperature during connection	- 5 °C ... + 50 °C
Degree of protection	IP 67
Reconnection with the same cable cross section	10 times

HARAX® M12-L screened version

	Ethernet, D-coded	Profibus
Rated voltage	32 V	32 V
Rated current	4 A	4 A
Conductor cross section	0.25 mm ² - 0.34 mm ² AWG 24-22	0.25 mm ² - 0.34 mm ² AWG 24-22
Diameter of individual strands	≥ 0.1 mm	≥ 0.1 mm
Conductor cross section of Solid wire	Result pending	AWG 22/1
Conductor insulation material	PVC	PVC
Conductor diameter	1.2 mm - 1.6 mm	2.0 mm - 2.6 mm
Cable diameter	5.5 mm - 7.2 mm	7 mm - 8.8 mm
Temperature limits	- 25 °C ... + 85 °C	- 25 °C ... + 85 °C
Temperature during connection	- 5 °C ... + 50 °C	- 5 °C ... + 50 °C
Degree of protection	IP 67	IP 67
Coding	d-coding	b-coding / reverse key
Reconnection with the same cable cross section	10 times	10 times
Transmission characteristics acc. to	DIN EN 50 173	-

	M12-L A-coded	Adapter M12-RJ45
Rated voltage	32 V	-
Rated current	4A	-
Conductor cross section	0,25 mm ² - 0,34 mm ² AWG 24 - 22	-
Diameter of individual strands	≥ 0.1 mm	-
Conductor cross section of Solid wire	Works with AWG 22/1	-
Conductor insulation material	PVC	-
Conductor diameter	1.6 mm - 2.0 mm	-
Cable diameter	7.0 mm - 8.8 mm	-
Working temperature	- 25 °C ... + 85 °C	- 25 °C ... + 85 °C
Temperature during connection	- 5 °C ... + 50 °C	- 5 °C ... + 50 °C
Degree of protection	IP 67	IP 65 / 67
Coding	a-coding	-
Number of terminations with same cable cross section	10	10
Transmission characteristics acc. to	-	DIN EN 50 173

HF Properties

acc. to DIN EN 50173

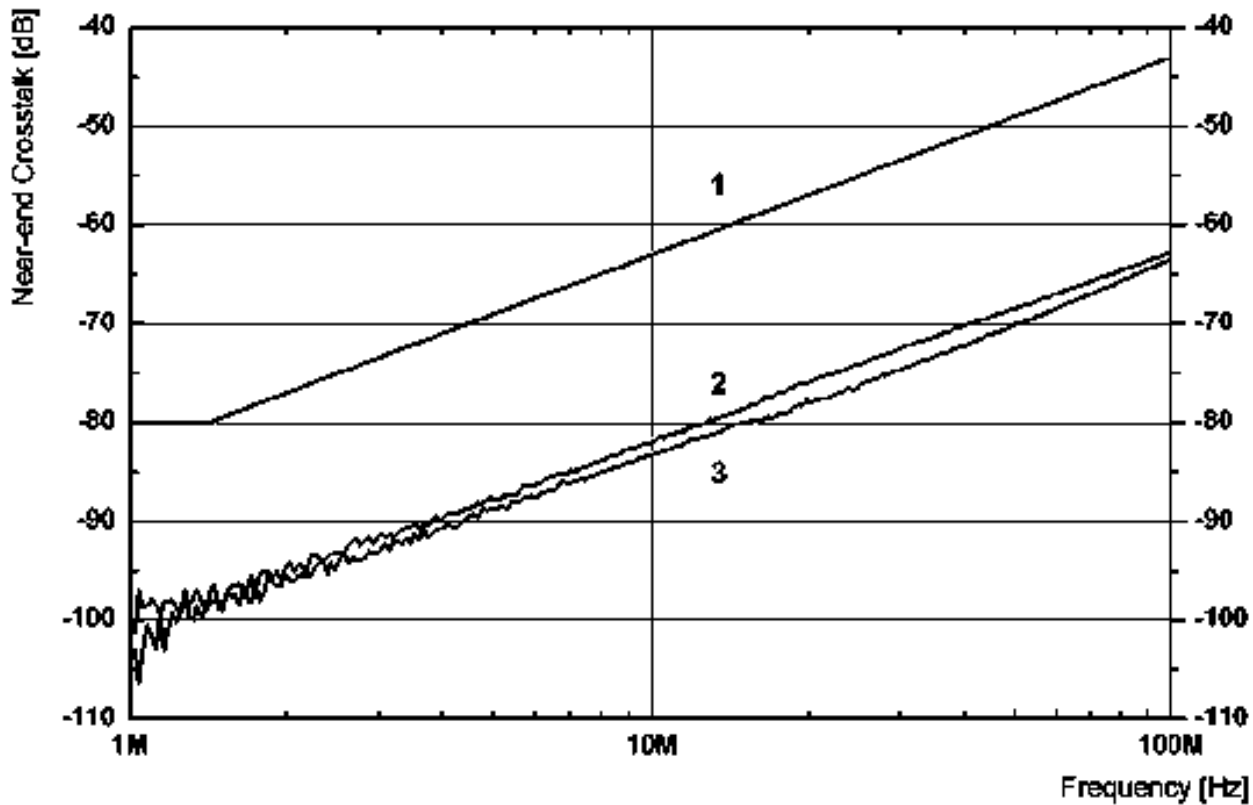

- 1= Limit acc. to DIN EN 50173, Category 5
- 2= Pin allocation diagonal wire pair 1/3 <-> 2/4
- 3= Pin allocation diagonal wire pair 2/4 <-> 1/3

Derating Diagramme

The current carrying capacity is limited by maximum temperature of materials for insert and contacts including terminals. The current capacity-curve is valid for continuous, not interrupted current-loaded contacts of connectors when simultaneous power on all contacts is given, without exceeding the maximum temperature.

Control and test procedures according to DIN IEC 60512-3.

M8-S, 4 poles

M12-S, 4 poles

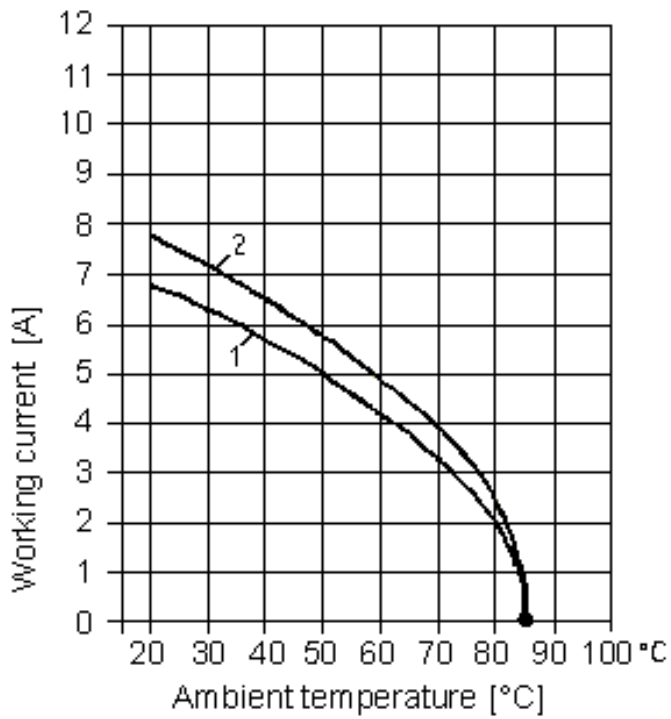

1 = wire gauge 0,25 mm²
 2 = wire gauge 0,34 mm²

M12, 4 poles, angled

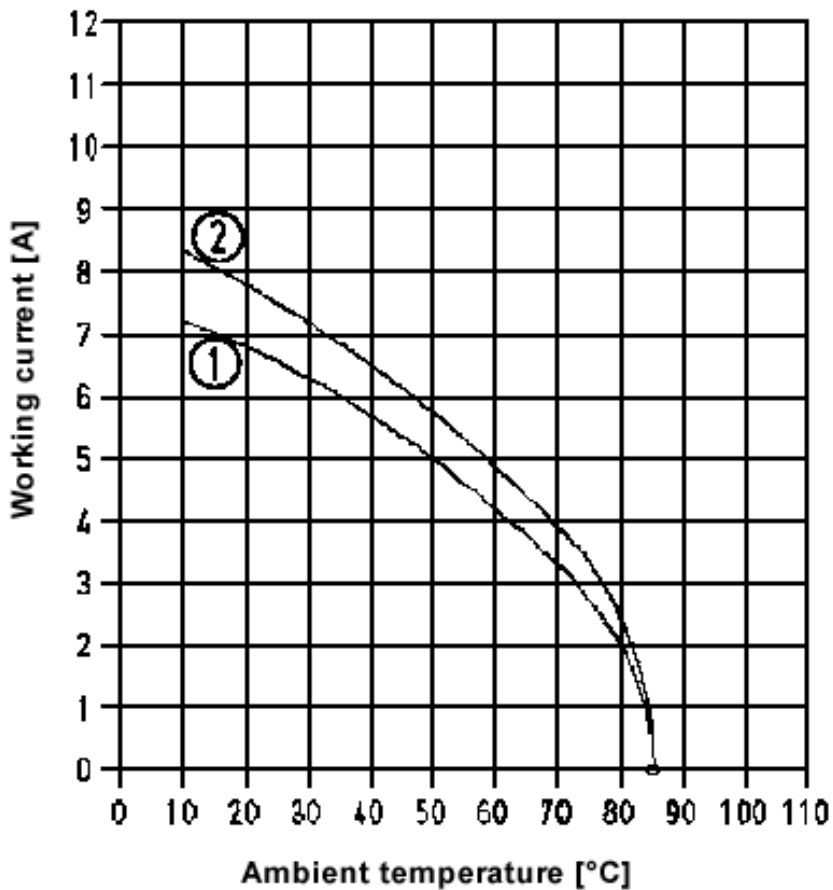

1 = wire gauge 0,25 mm²
 2 = wire gauge 0,5 mm²

M12-L, 4 poles
M12-L, shielded

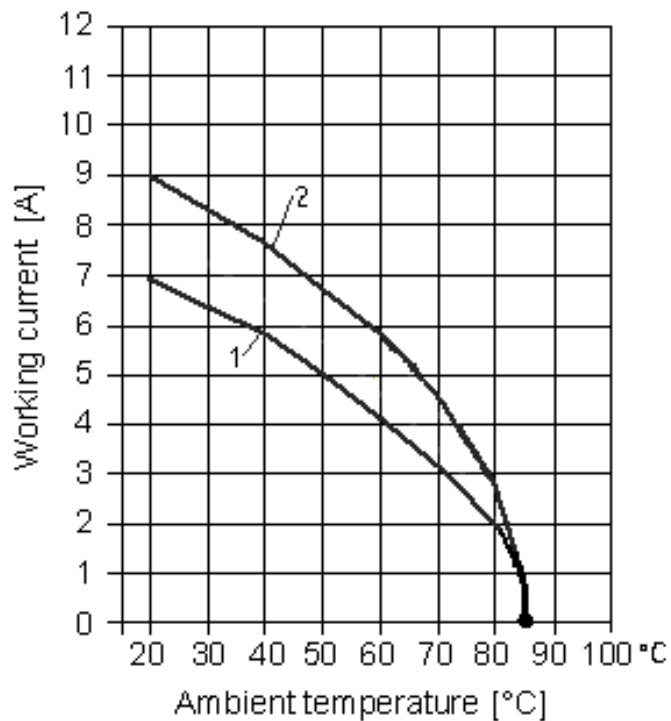

1 = wire gauge 4 x 0,34 mm²
2 = wire gauge 4 x 0,75 mm²

Assembly manual HARAX®

1. Strip cable
2. Assemble HARAX® elements
3. Cut off cable ends
4. Screw connector

- (1) Nut
- (2) Strain relief
- (3) Insert

Screw the nut onto the insert until a stop is noticeable.

Note!

For reconnection cut off the used cable ends and repeat steps 1 to 4.

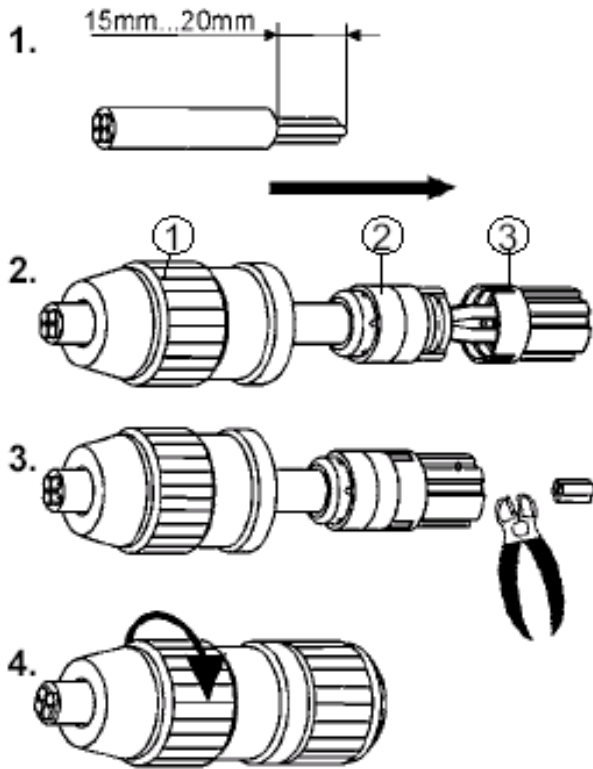

Assembly instruction for shielded *HARAX*® M12-L

1. Strip cable
2. Assemble *HARAX*® elements,
twist screening braid and push it into the sealing slot
3. Slide ring over the sealing
cut off cable ends and the screening braid.
4. Screw the connector
 - (1) Nut
 - (2) Strain relief
 - (3) Insert

Note!

For reconnection cut off the used cable end and repeat steps 1 to 4.

