

Customer Information Sheet

DWG No.: M90-3106F10SL-3S SHEET 2 OF 2 IF IN DOUBT - ASK © THIRD ANGLE PROJECTION NOT TO SCALE ALL DIMENSIONS IN mm

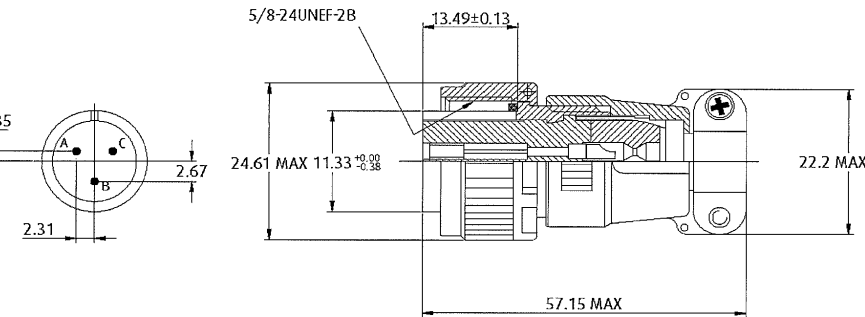

SPECIFICATIONS:

MATERIAL:

SHELL = ALUMINIUM ALLOY
 INSULATOR = POLYCHLOROPRENE
 GROMMET = POLYCHLOROPRENE
 CONTACT = COPPER ALLOY

FINISH:

SHELL = ZINC WITH BLACK CHROMATE COATING
 CONTACT = SILVER

ELECTRICAL:

CURRENT RATING = 13 AMPS
 VOLTAGE RATING = 500V AC, 700V DC
 INSULATION RESISTANCE = 5,000 MΩ MIN

ENVIRONMENTAL:

TEMPERATURE RANGE = -55°C TO +125°C
 VIBRATION = 10 - 500Hz (10G) PER MIL-STD-1344, Method 2005
 SALT SPRAY = 48 HRS, 5% SALT SOLUTION, PER MIL-STD-1344
 Method 1001

HUMIDITY = 95±3%, 71±2°C, 14 DAYS

MECHANICAL:

COUPLING : THREADED
 POLARISATION : SINGLE KEY/ KEYWAY
 CONTACT TYPE : SOLDER
 CONTACT ARRANGEMENT : 3 CONTACTS
 DURABILITY : 500 OPERATIONS

RA	3	15.01.09	10228
NAME	ISS.	DATE	C/NOTE
APPROVED			
CHECKED:			
DRAWN:	M.G.PLESTED		
CUSTOMER REF:			
ASSEMBLY DRG:			

NOTES:

1. PRODUCT IS RoHS COMPLIANT
2. PRODUCT IS PACKED IN BAGS
3. RECOMMENDED WIRE SIZE 16-22 AWG.

HARWIN

HARWIN USA TEL: 603 893 5376 FAX: 603 893 5396 @harwin.com	HARWIN Europe (UK) TEL: 023 9231 4545 FAX: 023 9231 4590 mis@harwin.co.uk	HARWIN Asia TEL: +65 6 779 4909 FAX: +65 6 779 3868 mis@harwin.com.sg
--	---	---

THIS INFORMATION AND ANY INFORMATION OR DESCRIPTIVE MATTER SET OUT HEREON ARE CONFIDENTIAL AND COPYRIGHT PROPERTY OF THE HARWIN GROUP AND MUST NOT BE DISCLOSED, LOANED, COPIED OR USED FOR MANUFACTURING, TENDERING OR FOR ANY OTHER PURPOSE WITHOUT THEIR WRITTEN PERMISSION.

TOLERANCES
 X. = ±1mm
 X.X = ±0.25mm
 X.XX = ±0.10mm
 X.XXX = ±0.01mm
 ANGLES = ±5°
 UNLESS STATED

MATERIAL:
SEE ABOVE

FINISH:
SEE ABOVE

S/AREA:

TITLE:
FREE PLUG - 3 SOCKET CONTACTS
DRAWING NUMBER:
M90-3106F10SL-3S
 SHT 2 OF 2

Customer Information Sheet

NG No.: M90-3106F10SL-4S SHEET 2 OF 2 IF IN DOUBT - ASK © THIRD ANGLE PROJECTION NOT TO SCALE ALL DIMENSIONS IN mm

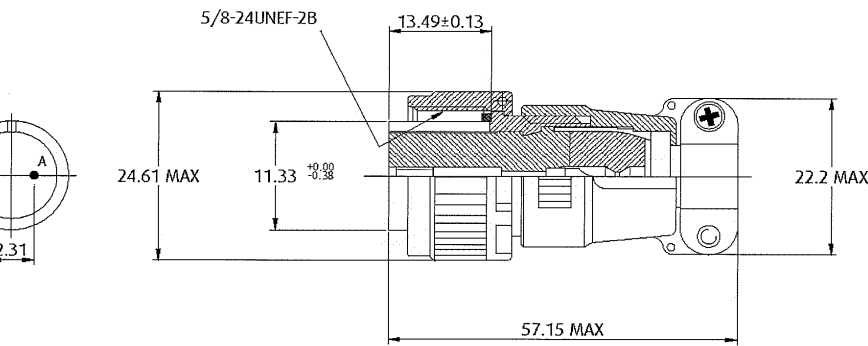

SPECIFICATIONS:

MATERIAL:

SHELL = ALUMINIUM ALLOY
 INSULATOR = POLYCHLOROPRENE
 GROMMET = POLYCHLOROPRENE
 CONTACT = COPPER ALLOY

FINISH:

SHELL = ZINC WITH BLACK CHROMATE COATING
 CONTACT = SILVER

ELECTRICAL:

CURRENT RATING = 13 AMPS
 VOLTAGE RATING = 500V AC, 700V DC
 INSULATION RESISTANCE = 5,000 MΩ MIN

ENVIRONMENTAL:

TEMPERATURE RANGE = -55°C TO +125°C
 VIBRATION = 10 - 500Hz (10G) PER MIL-STD-1344, Method 2005
 SALT SPRAY = 48 HRS, 5% SALT SOLUTION, PER MIL-STD-1344
 Method 1001

HUMIDITY = 95±3%, 71±2°C, 14 DAYS

MECHANICAL:

COUPLING : THREADED
 POLARISATION : SINGLE KEY/ KEYWAY
 CONTACT TYPE : SOLDER
 CONTACT ARRANGEMENT : 2 CONTACTS
 DURABILITY : 500 OPERATIONS

RA	3	15.01.09	10228
NAME	ISS.	DATE	C/NOTE
APPROVED			
CHECKED:			
DRAWN:	M.G.PLESTED		
CUSTOMER REF:			
ASSEMBLY DRG:			

NOTES:

1. PRODUCT IS RoHS COMPLIANT
2. PRODUCT IS PACKED IN BAGS
3. RECOMMENDED WIRE SIZE 16-22 AWG.

HARWIN

HARWIN USA 603 893 5376 603 893 5396 @harwin.com	HARWIN Europe (UK) TEL: 023 9231 4545 FAX: 023 9231 4590 mis@harwin.co.uk	HARWIN Asia TEL: +65 6 779 4909 FAX: +65 6 779 3868 mis@harwin.com.sg
--	---	---

THIS INFORMATION AND ANY INFORMATION OR DESCRIPTIVE MATTER SET OUT HEREON ARE CONFIDENTIAL AND COPYRIGHT PROPERTY OF THE HARWIN GROUP AND MUST NOT BE DISCLOSED, LOANED, COPIED OR USED FOR MANUFACTURING, TENDERING OR FOR ANY OTHER PURPOSE WITHOUT THEIR WRITTEN PERMISSION.

TOLERANCES
 X. = ±1mm
 X.X = ±0.25mm
 X.XX = ±0.10mm
 X.XXX = ±0.01mm
ANGLES = ±5°
 UNLESS STATED

MATERIAL:
 SEE ABOVE
FINISH:
 SEE ABOVE
S/AREA:

TITLE:
 FREE PLUG -
 2 SOCKET CONTACTS
DRAWING NUMBER:
M90-3106F10SL-4S
 SHT
 2
 OF
 2

Customer Information Sheet

NG No.: M90-3106F12S-3S SHEET 1 OF 2 IF IN DOUBT - ASK (C) NOT TO SCALE THIRD ANGLE PROJECTION ALL DIMENSIONS IN mm

SPECIFICATIONS:
MATERIAL:
 SHELL: ALUMINIUM ALLOY
 INSULATOR: NITRILE BUTADIENE RUBBER
 CONTACT: NITRILE BUTADIENE RUBBER
 CONTACT COPPER ALLOY
FINISH:
 SHELL: ZINC PLATED WITH BLACK CHROMATE COATING
 CONTACT: SILVER
ELECTRICAL:
 CURRENT RATING: 13 AMPS
 VOLTAGE RATING: 500V AC, 700V DC
 INSULATION RESISTANCE: 5,000 MΩ MIN
Mechanical:
 MOUNTING: THREADED
 POLARISATION: SINGLE KEY/KEYWAY
 CONTACT TYPE: SOLDER
 CONTACT ARRANGEMENT: 2 CONTACTS
 RELIABILITY: 500 CYCLES
ENVIRONMENTAL:
 OPERATING RANGE: -55°C TO -125°C
 VIBRATION: 10-500Hz(10G), PER MIL-STD-1344, METHOD 2005
 SALT SPRAY: 48HRS. SALT SOLUTION 5%, PER MIL-1344, METHOD 1001
 HUMIDITY: RELATIVE HUMIDITY 95±3%, 71°C±2°C, 14 DAYS

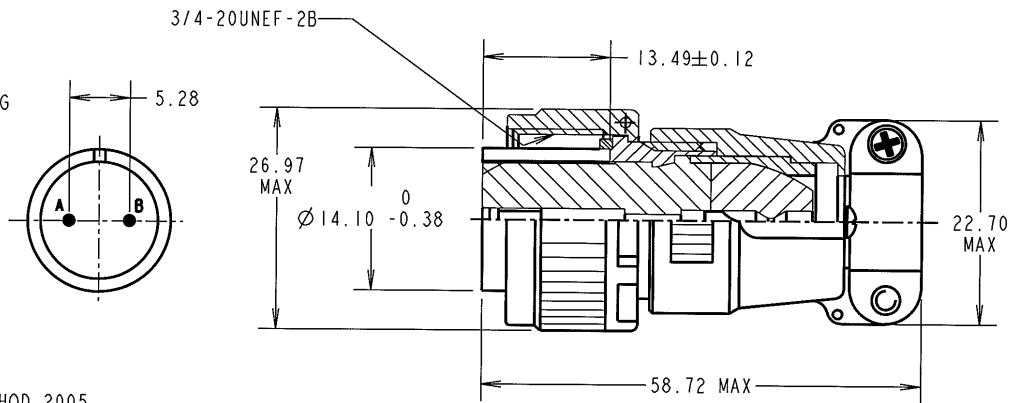

- NOTES:**
 1. PRODUCT IS RoHS COMPLIANT
 2. PRODUCT IS PACKED IN BAGS.
 3. RECOMMENDED WIRE SIZE 16-22 AWG.

RA	2	16.01.09	10228
NAME	ISS.	DATE	C/NOTE
APPROVED: <i>[Signature]</i>			
CHECKED: <i>[Signature]</i>			
DRAWN: R. ADDE			
CUSTOMER REF.:			
ASSEMBLY DRG:			

HARWIN

HARWIN USA TEL: 03 893 5376 FAX: 03 893 5396 harwin.com	HARWIN Europe (UK) TEL: 023 9231 4545 FAX: 023 9231 4590 mis@harwin.co.uk	HARWIN Asia TEL: +65 6 779 4909 FAX: +65 6 779 3868 mis@harwin.com.sg
--	--	--

THIS DRAWING AND ANY INFORMATION OR DESCRIPTIVE MATTER SET OUT HEREON ARE CONFIDENTIAL AND COPYRIGHT PROPERTY OF THE HARWIN GROUP AND MUST NOT BE DISCLOSED, LOANED, COPIED OR USED FOR MANUFACTURING, TENDERING OR FOR ANY OTHER PURPOSE WITHOUT THEIR WRITTEN PERMISSION.

TOLERANCES
 X. = ±1mm
 X.X = ±0.25mm
 X.XX = ±0.10mm
 X.XXX = ±0.01mm
 ANGLES = ±5°
 UNLESS STATED

MATERIAL:
 SEE ABOVE
FINISH:
S/AREA: mm²

TITLE:
 CABLE CONNECTOR-
 2 PIN CONTACTS
DRAWING NUMBER:
 M90-3106F12S-3S
 SHT 2 OF 2

Customer Information Sheet

ING No.: M90-3106F14S-2S SHEET 2 OF 2 IF IN DOUBT - ASK © THIRD ANGLE PROJECTION NOT TO SCALE ALL DIMENSIONS IN mm

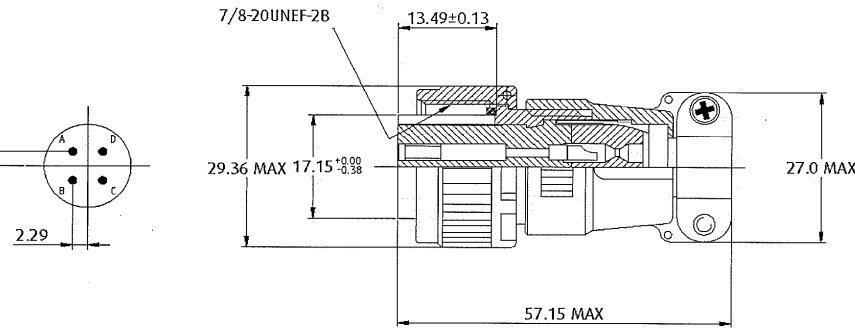

SPECIFICATIONS:

MATERIAL:

SHELL = ALUMINIUM ALLOY
 INSULATOR = POLYCHLOROPRENE
 GROMMET = POLYCHLOROPRENE
 CONTACT = COPPER ALLOY

FINISH:

SHELL = ZINC WITH BLACK CHROMATE COATING
 CONTACT = SILVER

ELECTRICAL:

CURRENT RATING = 13 AMPS
 VOLTAGE RATING = 200V AC, 250V DC
 INSULATION RESISTANCE = 5,000 MΩ MIN

ENVIRONMENTAL:

TEMPERATURE RANGE = -55°C TO +125°C
 VIBRATION = 10 - 500Hz (10G) PER MIL-STD-1344, Method 2005
 SALT SPRAY = 48 HRS, 5% SALT SOLUTION, PER MIL-STD-1344

Method 1001

HUMIDITY = 95±3%, 71±2°C, 14 DAYS

MECHANICAL:

COUPLING : THREADED
 POLARISATION : SINGLE KEY/ KEYWAY
 CONTACT TYPE : SOLDER
 CONTACT ARRANGEMENT : 4 CONTACTS
 DURABILITY : 500 OPERATIONS

RA	4	15.01.09	10198
NAME	ISS.	DATE	C/NOTE
APPROVED <i>[Signature]</i>			
CHECKED: <i>[Signature]</i>			
DRAWN: M.G.PLESTED			
CUSTOMER REF:			
ASSEMBLY DRG:			

NOTES:

1. PRODUCT IS RoHS COMPLIANT
2. PRODUCT IS PACKED IN BAGS
3. RECOMMENDED WIRE SIZE 16-22 AWG.

HARWIN

HARWIN USA 603 893 5376 603 893 5396 @harwin.com	HARWIN Europe (UK) TEL: 023 9231 4545 FAX: 023 9231 4590 mis@harwin.co.uk	HARWIN Asia TEL: +65 6 779 4909 FAX: +65 6 779 3868 mis@harwin.com.sg
--	---	---

THIS INFORMATION AND ANY INFORMATION OR DESCRIPTIVE MATTER SET OUT HEREON ARE CONFIDENTIAL AND COPYRIGHT PROPERTY OF THE HARWIN GROUP AND MUST NOT BE DISCLOSED, LOANED, COPIED OR USED FOR MANUFACTURING, TENDERING OR FOR ANY OTHER PURPOSE WITHOUT THEIR WRITTEN PERMISSION.

TOLERANCES
 X. = ±1mm
 X.X = ±0.25mm
 X.XX = ±0.10mm
 X.XXX = ±0.01mm
 ANGLES = ±5°
 UNLESS STATED

MATERIAL:
SEE ABOVE

FINISH:
SEE ABOVE

S/AREA:

TITLE: FREE PLUG - 4 SOCKET CONTACTS	
DRAWING NUMBER: M90-3106F14S-2S	SHT 2 OF 2

Customer Information Sheet

DWG No.: M90-3106F14S-6S SHEET 2 OF 2 IF IN DOUBT - ASK © THIRD ANGLE PROJECTION NOT TO SCALE ALL DIMENSIONS IN mm

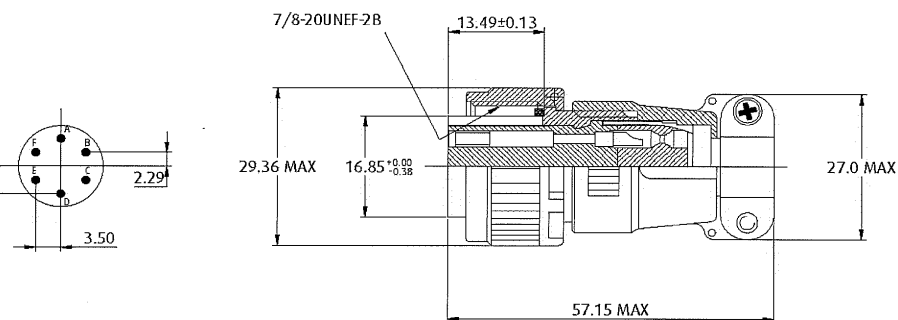

SPECIFICATIONS:

MATERIAL:

SHELL = ALUMINIUM ALLOY
 INSULATOR = POLYCHLOROPRENE
 GROMMET = POLYCHLOROPRENE
 CONTACT = COPPER ALLOY

FINISH:

SHELL = ZINC WITH BLACK CHROMATE COATING
 CONTACT = SILVER

ELECTRICAL:

CURRENT RATING = 13 AMPS
 VOLTAGE RATING = 200V AC, 250V DC
 INSULATION RESISTANCE = 5,000 MΩ MIN

ENVIRONMENTAL:

TEMPERATURE RANGE = -55°C TO +125°C
 VIBRATION = 10 - 500Hz (10G) PER MIL-STD-1344, Method 2005
 SALT SPRAY = 48 HRS, 5% SALT SOLUTION, PER MIL-STD-1344
 Method 1001

HUMIDITY = 95±3%, 71±2°C, 14 DAYS

MECHANICAL:

COUPLING : THREADED
 POLARISATION : SINGLE KEY/ KEYWAY
 CONTACT TYPE : SOLDER
 CONTACT ARRANGEMENT : 6 CONTACTS
 DURABILITY : 500 OPERATIONS

RA	4	15.01.09	10228
NAME	ISS.	DATE	C/NOTE
APPROVED			
CHECKED:			
DRAWN:	M.G.PLESTED		
CUSTOMER REF:			
ASSEMBLY DRG:			

NOTES:

1. PRODUCT IS RoHS COMPLIANT
2. PRODUCT IS PACKED IN BAGS
3. RECOMMENDED WIRE SIZE 16-22 AWG.

HARWIN

HARWIN USA TEL: 603 893 5376 FAX: 603 893 5396 @harwin.com	HARWIN Europe (UK) TEL: 023 9231 4545 FAX: 023 9231 4590 mis@harwin.co.uk	HARWIN Asia TEL: +65 6 779 4909 FAX: +65 6 779 3868 mis@harwin.com.sg
---	--	--

THIS INFORMATION AND ANY INFORMATION OR DESCRIPTIVE MATTER SET OUT HEREON ARE CONFIDENTIAL AND COPYRIGHT PROPERTY OF THE HARWIN GROUP AND MUST NOT BE DISCLOSED, LOANED, COPIED OR USED FOR MANUFACTURING, TENDERING OR FOR ANY OTHER PURPOSE WITHOUT THEIR WRITTEN PERMISSION.

TOLERANCES
 X. = ±1mm
 X.X = ±0.25mm
 X.XX = ±0.10mm
 X.XXX = ±0.01mm
 ANGLES = ±5°
 UNLESS STATED

MATERIAL:
 SEE ABOVE
FINISH:
 SEE ABOVE
S/AREA:

TITLE: FREE PLUG - 6 SOCKET CONTACTS	
DRAWING NUMBER: M90-3106F14S-6S	SHT 2 OF 2