

THE INFORMATION CONTAINED IN THIS DRAWING IS THE SOLE PROPERTY OF L-COM, INC. ANY REPRODUCTION IN PART OR WHOLE WITHOUT THE WRITTEN PERMISSION OF L-COM, INC. IS PROHIBITED.

REVISIONS			
REV	DESCRIPTION	DATE	APPROVED
A	INITIAL RELEASE	01/16/06	D. PARHAM
B	ECN 3241: 1.30 WAS 1.5	3/19/08	D. CASTRO

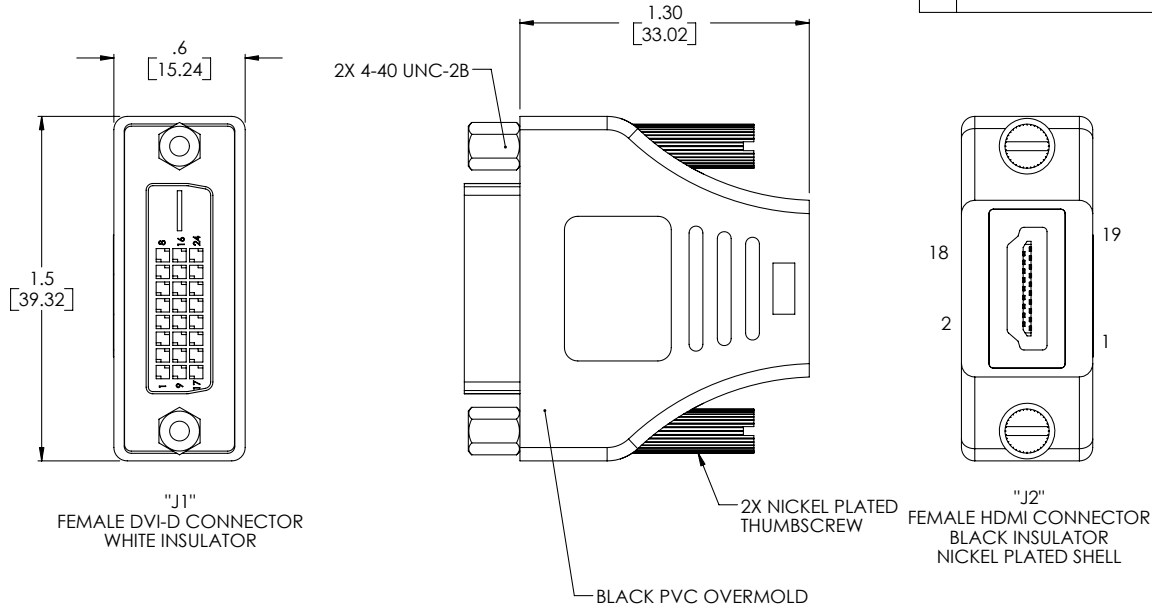

WIRING MAP	
"J1"	"J2"
2	1
3	2
1	3
10	4
11	5
9	6
18	7
19	8
17	9
23	10
22	11
24	12
6	15
7	16
15	17
14	18
16	19
SHELL	SHELL

NOTES:

ELECTRICAL:
 UNLESS OTHERWISE SPECIFIED, WIRING IS STRAIGHT THROUGH FROM PIN TO PIN.
 EACH ADAPTOR SHALL BE SUBJECTED TO AND PASS A CONTINUITY TEST.
 INSULATION RESISTANCE: 20 MOHMS
 CONTACT RESISTANCE: 1 OHM MAX

PACKAGING:
 INDIVIDUALLY PACKAGE EACH ADAPTOR UTILIZING APPROPRIATE SIZED BAG

UNLESS OTHERWISE SPECIFIED, DIMENSIONS ARE IN INCHES [mm] OVERALL CABLE LENGTH TOLERANCE: ≤12 [305] = +1 [25] / -0 >12 [305] ≤60 [1524] = ±2 [51] / -0 >60 [1524] ≤120 [3048] = +4 / -0 >120 [3048] ≤300 [7620] = +6 / -0 >300 [7620] = +3% / -0% ALL OTHER DIMENSIONAL TOLERANCES: .X = .3 .XX = .15	APPROVALS DRAWN BY: D. PARHAM CHECKED BY: J. KIEZULAS APPROVED BY: C. MCCORMICK	DATE 01/13/2006 01/13/2006 01/16/2006	45 BEECHWOOD DRIVE NORTH ANDOVER, MA 01845
	CONFIGURATION DETAILS OF UNDIMENSIONED FEATURES MAY VARY		
PROJECTION 	COLOR VARIATIONS MAY OCCUR	PRODUCT DESCRIPTION ADAPTOR DVI-D F/ HDMI F	REV. B
SCALE: NONE		FSCM NO. 43321 DWG. NO. DVIHDF	SHEET 1 OF 1