

# OEM Serial Port Adapter™

cB-OEMSPA311 / 331, cB-0901

Electrical & Mechanical Datasheet

*connectBlue*

**OEM Serial Port Adapter™  
cB-0901**

**Electrical & Mechanical Datasheet**

Copyright © 2006 connectBlue AB.

The contents of this document can be changed by connectBlue AB without prior notice and do not constitute any binding undertakings from connectBlue AB. connectBlue AB is not responsible under any circumstances for direct, indirect, unexpected damage or consequent damage that is caused by this document.

All rights reserved.

Release: 2009-12

Document version: 1.16

Document number: cBProduct-0410-04

Printed in Sweden.

### **Trademarks**

Registered trademarks from other companies are: Bluetooth is a trademark owned by the Bluetooth SIG, Inc., Microsoft™, Windows™, Windows NT™, Windows 2000™, Windows CE™, Windows ME™, are registered trademarks from Microsoft Corporation.

---

# Contents

---

<b>1</b>	<b>Introduction</b>	<b>5</b>
1.1	Migrating from Bluetooth 1.1 to 2.0 products.....	5
1.2	Related Documents .....	5
1.3	Product Variants .....	6
1.4	cB-0901 .....	7
1.5	Block Diagram cB-0901 .....	8
<b>2</b>	<b>Electrical Interface and Connectors</b>	<b>9</b>
2.1	Pin Numbering .....	10
2.2	Pin Description .....	11
2.3	Characteristics .....	20
2.4	Hardware Reset .....	24
2.5	Power Control .....	24
<b>3</b>	<b>Operating Status</b>	<b>25</b>
<b>4</b>	<b>Antennas</b>	<b>26</b>
4.1	Surface Mounted Antenna (Internal).....	26
4.2	External antennas .....	27
<b>5</b>	<b>Mounting Information</b>	<b>30</b>
5.1	Board Outlines .....	30
5.2	Using the J2/J3 Board-to-Board Connectors.....	32
5.3	Using Press-Fit Nuts for Mounting the Module .....	36
5.4	Using the J6 PCB solder pads on the edge.....	36
5.5	Antenna Issues .....	37
<b>6</b>	<b>Bluetooth Information</b>	<b>38</b>
6.1	General information .....	38
6.2	Bluetooth Qualification information .....	39
<b>7</b>	<b>Regulatory Information</b>	<b>40</b>
7.1	Declaration of Conformity .....	40
7.2	Safety Compliance .....	41
7.3	FCC and IC Compliance .....	41
7.4	Japanese Approval Certificate for cB-0901-0301 .....	44
7.5	UL listing information .....	45
7.6	Compliance with RoHS directive.....	45
<b>8</b>	<b>Guidelines for Efficient and Safe Use</b>	<b>46</b>
8.1	General .....	46
8.2	Product Care .....	46
8.3	Radio Frequency Exposure .....	46
8.4	Electronic Equipment .....	47
8.5	Potentially Explosive Atmospheres.....	47
8.6	Power Supply .....	47
<b>Appendix A -</b>	<b>Application Notes</b>	<b>48</b>
A.1	Step-by-Step Guide .....	48
A.2	Design Examples .....	49

---

# 1 Introduction

---

## 1.1 Migrating from Bluetooth 1.1 to 2.0 products

A migration from a cB-OEMSPA13 or cB-OEMSPA33 module to a cB-OEMSPA311 or cB-OEMSPA331 module is normally done without any problems. Even so, there are some issues that have to be considered.

- The resistance value of the pull-down resistors needs to be decreased to 1k $\Omega$ . It is especially important to be observant on the Mode and Switch-1 signals. This point is not necessary for the cB-OEMSPA333 modules and 10k $\Omega$  can still be used. See the LED and Switch Design Examples for more info.
- The High- and Low-signal definitions are slightly changed on the Logic Level signals. Especially consider the Low-level definition on the Switch-0 signal. See the Input/Output signals in the Characteristics section for more info.
- A 5V system using resistor dividers to adapt the 5V TxD output signal of the host to the 3V levels of the OEMSPA RxD input signal should decrease the resistor values to 1.8k $\Omega$  and 2.2k $\Omega$ . See the Logic Levels Design Examples for more info.

## 1.2 Related Documents

There are some documents related to the Serial Port Adapter:

- The **Serial Port Adapter AT Commands** document contains a description of the AT commands supported in the Serial Port Adapter. It also contains information on how to use the AT commands to create Bluetooth applications.
- The **OEM Serial Port Adapter Electrical & Mechanical Datasheet** (this document) contains important information about the OEM Serial Port Adapter. Read this document if you are using the OEM Serial Port Adapter.

## 1.3 Product Variants

This Electrical and Mechanical datasheet contains information about the 12 variants of OEM Serial Port Adapters based on the PCB cB-0901. This document makes references to the OEM Module ID, not the Product Name (see Table 1).

**Table 1: Product variants**

	Product Name	OEM Module ID / Regulatory ID / FCC ID	Bluetooth Type	Description
Class 1 +7dBm Internal antenna	cB-OEMSPA311i-04	cB-0052 cB-0901-0301 PVH090103S	Class 1 / +7dBm 5mW	OEM Serial Port Adapter 311i with internal antenna, no connectors
	cB-OEMSPA311i-06	cB-0054 cB-0901-0301 PVH090103S	Class 1 / +7dBm 5mW	OEM Serial Port Adapter 311i with internal antenna, JST 6- pol
	cB-OEMSPA311i-07	cB-0055 cB-0901-0301 PVH090103S	Class 1 / +7dBm 5mW	OEM Serial Port Adapter 311i with internal antenna, Flex- film
Class 1 +7dBm External antenna	cB-OEMSPA311x-04	cB-0056 cB-0901-0301 PVH090103S	Class 1 / +7dBm 5mW	OEM Serial Port Adapter 311x with external antenna, no connectors
	cB-OEMSPA311x-06	cB-0058 cB-0901-0301 PVH090103S	Class 1 / +7dBm 5mW	OEM Serial Port Adapter 311x with external antenna, JST 6-pol
	cB-OEMSPA311x-07	cB-0059 cB-0901-0301 PVH090103S	Class 1 / +7dBm 5mW	OEM Serial Port Adapter 311x with external antenna, Flexfilm
Class 1 +17dBm Internal antenna	cB-OEMSPA331i-04	cB-0060 cB-0901-0302 PVH090103L	Class 1 / +16.9dBm 49mW	OEM Serial Port Adapter 331i with internal antenna, no connectors
	cB-OEMSPA331i-06	cB-0062 cB-0901-0302 PVH090103L	Class 1 / +16.9dBm 49mW	OEM Serial Port Adapter 331i with internal antenna, JST 6- pol
	cB-OEMSPA331i-07	cB-0063 cB-0901-0302 PVH090103L	Class 1 / +16.9dBm 49mW	OEM Serial Port Adapter 331i with internal antenna, Flex- film
Class 1 +17dBm External antenna	cB-OEMSPA331x-04	cB-0064 cB-0901-0302 PVH090103L	Class 1 / +16.9dBm 49mW	OEM Serial Port Adapter 331x with external antenna, no connectors
	cB-OEMSPA331x-06	cB-0066 cB-0901-0302 PVH090103L	Class 1 / +16.9dBm 49mW	OEM Serial Port Adapter 331x with external antenna, JST 6-pol
	cB-OEMSPA331x-07	cB-0067 cB-0901-0302 PVH090103L	Class 1 / +16.9dBm 49mW	OEM Serial Port Adapter 331x with external antenna, Flexfilm

---

## 1.4 cB-0901

cB-0901 is a small size Bluetooth module based on the Phillips BGB203 system in package (SiP). The BGB203 has on chip SRAM and FLASH stacked in the same package. The modules are available in many variants with different antenna / connectors and output power combinations. See Picture 1 - Picture 3 for some of the available models. All models are described in Table 1.



**Picture 1: CB-OEMSPA331x-06  
OEM Serial Port Adapter long  
range with external antenna and a  
JST 6-pol connector**



**Picture 2: CB-OEMSPA311i-07  
OEM Serial Port Adapter short  
range with internal antenna and a  
flexfilm connector**



**Picture 3: CB-OEMSPA331i-06  
OEM Serial Port Adapter long  
range with internal antenna and a  
JST 6-pol connector**

## 1.5 Block Diagram cB-0901

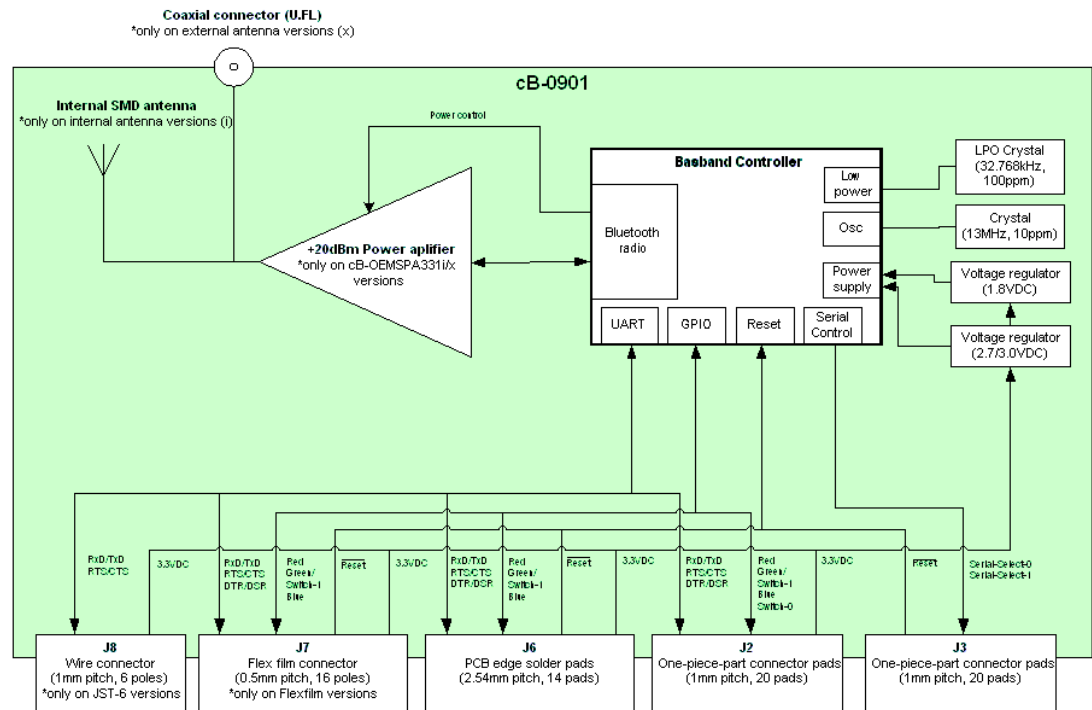


Figure 1: Block diagram of cB-0901



---

## 2 Electrical Interface and Connectors

---

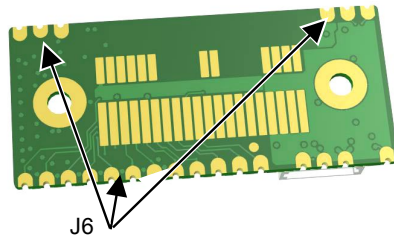
This section describes the signals available on the module interface connectors.

There are four ways to connect to the OEM Serial Port Adapter:

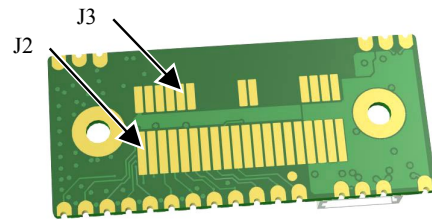
- Via the PCB solder pads on the edge of the PCB, J6 (see Picture 4). See Section 5.4 for more information.
- Via the 2x20-pin 1mm pitch board-to-board (one piece part) connectors, J2 through J3. The J2 to J3 connectors on the OEM Serial Port Adapter exist on the module only as a mating PCB-layout pattern (see Picture 5). See Section 5.2 for more information.

Optional:

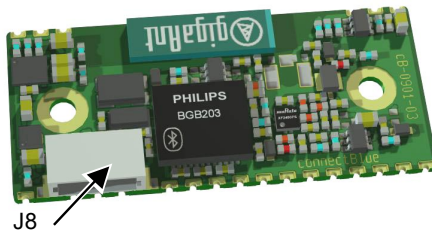
- Via the JST connector, J8 (see Picture 6). The connector is a 6 poles wire connector. The pitch is 1mm and the. The connector is from JST with part number SM06B-SRSS-TB.
- Via the flexfilm connector, J7 (see Picture 7). The connector is a 16 poles flexfilm connector. The pitch is 0.5mm and the flexfilm should be 0.3mm thick. The connector is from Hirose with part number FH19S-16S-0.5SH(05).



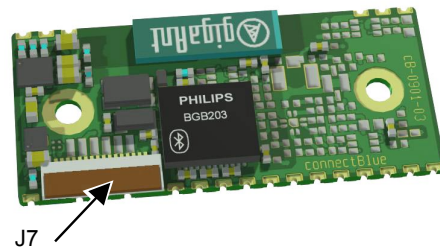
Picture 4: J6 are available on the edge of the cB-0901.



Picture 5: J2 to J3 are available on cB-0901. Some of the not used pads are not visible.



Picture 6: JST 6-pol connector, J8.



Picture 7: Flexfilm connector, J7.

---

## 2.1 Pin Numbering

### 2.1.1 J2, J3 and J6 Connectors

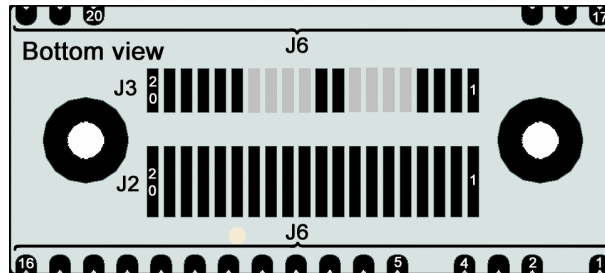


Figure 2: Bottom view of the PCB with the pinning of the J2, J3 and the J6 connector.

### 2.1.2 JST 6-pol, J8

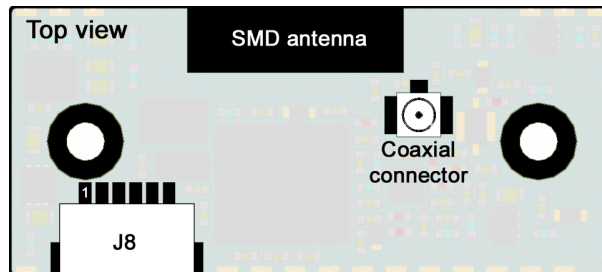


Figure 3: Top view of the PCB with the pinning of the J8 connector.

### 2.1.3 Flexfilm, J7

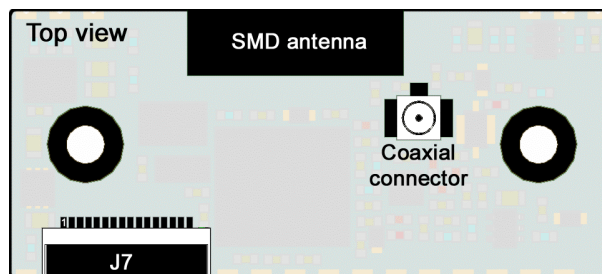


Figure 4: Top view of the PCB with the pinning of the J7 connector.

---

## 2.2 Pin Description

### 2.2.1 J2 Connector

**Table 2: Signals on J2.**

J2 Pin Nr	Pin Name	Signal Name	Signal Level	Type	Description
1-2	VSS	Ground	Ground		GND
3-4	VCC_3V3	Power	3.3V		3.0 – 6.0 VDC for CB-OEMSPA311 modules  3.3 – 6.0 VDC for CB-OEMSPA331 modules
5-10		Reserved			Reserved, do not connect.
11	RED/Mode	Red LED output	CMOS	In/Out	RED: Logic Red LED Signal (see Chapter 3, Table 14). Active low.  Mode: <b>Not used on cB-0901.</b> This pin is also used to select Logic level mode (instead of RS232) for connectBlue product with internal RS232 driver. To be compatible with these products check the datasheet for these products about this signal.  The pin is not allowed to be pull- down when using the SerialSelect signals.
12	Switch-0	Function switch	CMOS	In	Used for the “Connect on external signal” function, see the Serial Port Adapter AT command Specification for more information on the Func- tion switch. Active low.  See section A.2.3.4 for design ex- amples.

J2 Pin Nr	Pin Name	Signal Name	Signal Level	Type	Description
13	GREEN/ Switch-1	Green LED output and Restore switch	CMOS	In/Out	<p>This signal is multiplexed:</p> <p>GREEN: Logic Green LED Signal (see Chapter 3, Table 14). Not valid until 500ms after startup. Active low.</p> <p>Switch-1: If the level on this pin is pulled-down with 1k<math>\Omega</math>** the units goes back to default serial settings. The module will restore all factory settings if both the Switch-1 and Switch-0 signals are low during start up.</p> <p>The "Restore Default" input is only active during the first 500ms after startup.</p> <p>See the Serial Port Adapter AT command Specification for more information on the Restore switch.</p> <p>See section A.2.3.2 for design examples.</p>
14	BLUE	Blue LED output	CMOS	Out	<p>Logic Blue LED Signal (see Chapter 3, Table 14). Active low.</p> <p>Note: Signal will flicker at data transmission.</p> <p>See section A.2.3.1 for design examples.</p>
15	UART-CTS*	Clear To Send	CMOS	In	<p>Hardware flow control.</p> <p>Active low.</p>
16	UART-TxD*	Transmit Data	CMOS	Out	"0" : Low, "1" : High
17	UART-RTS*	Request To Send	CMOS	Out	<p>Hardware flow control.</p> <p>Active low.</p>
18	UART-RxD*	Receive Data	CMOS	In	"0" : Low, "1" : High
19	UART-DTR*	Data Terminal Ready	CMOS	Out	Active low.
20	UART-DSR*	Data Set Ready	CMOS	In	<p>Active low.</p> <p>Also used to control the power saving mode "stop mode".</p> <p>See section 2.5 for more information.</p>

\* All signals are logic level UART signals (typically 0 - 3VDC)

\*\* Use 1k $\Omega$  as pull-down which is different to previous product generations from connectBlue

---

## 2.2.2 J3 Connector

**Table 3: Signals on J3**

J3 Pin Nr	Pin Name	Signal Name	Signal Level	Type	Description
1-8					Reserved, do not connect.
9	SerialSelect-0	Serial Select 0	CMOS	Out	Control signal for external serial transceivers. See section A.2.2.4 for more info.
10	SerialSelect-1	Serial Select 1	CMOS	Out	Control signal for external serial transceivers. See section A.2.2.4 for more info.
11-18					Reserved, do not connect.
19	<u>RESET</u>	Hardware reset	CMOS	In	Active low. Must be open drain collector. See section 2.4 for design examples.
20					Reserved, do not connect.

---

## 2.2.3 J6 Connector (Solder pads)

**Table 4: Signals on J6**

J6 Pin Nr	Pin Name	Signal Name	Signal Level	Type	Description
1	RESET	Hardware reset	CMOS	In	Active low. Must be open drain collector.  See section 2.4 for design examples.
2	VSS	Ground	Ground		GND
3	VCC_3V3	Power	3.3V		3.0 – 6.0 VDC for CB-OEMSPA311 modules  3.3 – 6.0 VDC for CB-OEMSPA331 modules
4	UART-DTR*	Data Terminal Ready	CMOS	Out	Active low.
5	RED/Mode	Red LED output	CMOS	Out	RED: Logic Red LED Signal (see Chapter 3, Table 14). Active low.  Mode: <b>Not used on cB-0901.</b> This pin is also used to select Logic level mode (instead of RS232) for connectBlue product with internal RS232 driver. To be compatible with these products check the datasheet for these products about this signal.  The pin is not allowed to be pull-down when using the SerialSelect signals.

---

J6 Pin Nr	Pin Name	Signal Name	Signal Level	Type	Description
6	GREEN/ Switch-1	Green LED output and Restore switch	CMOS	In/Out	<p>This signal is multiplexed:</p> <p><b>GREEN:</b> Logic Green LED Signal (see Chapter 3, Table 14). Not valid until 500ms after startup. Active low.</p> <p><b>Switch-1:</b> If the level on this pin is pulled-down with 1k<math>\Omega</math>** the units goes back to default serial settings. The module will restore all factory settings if both the Switch-1 and Switch-0 signals are low during start up.</p> <p>The "Restore Default" input is only active during the first 500ms after startup.</p> <p>See the Serial Port Adapter AT command Specification for more information on the Restore switch.</p> <p>See section A.2.3.2 for design examples.</p>
7	BLUE	Blue LED output	CMOS	Out	<p>Logic Blue LED Signal (see Chapter 3, Table 14). Active low.</p> <p>Note: Signal will flicker at data transmission.</p> <p>See section A.2.3.1 for design examples.</p>
8	UART-CTS*	Clear To Send	CMOS	In	<p>Hardware flow control.</p> <p>Active low.</p>
9	UART-TxD*	Transmit Data	CMOS	Out	<p>"0" : Low, "1" : High</p>
10	UART-RTS*	Request To Send	CMOS	Out	<p>Hardware flow control.</p> <p>Active low.</p>
11	UART-RxD*	Receive Data	CMOS	In	<p>"0" : Low, "1" : High</p>
12-15					Reserved, do not connect.

---

<b>J6 Pin Nr</b>	<b>Pin Name</b>	<b>Signal Name</b>	<b>Signal Level</b>	<b>Type</b>	<b>Description</b>
16	UART-DSR*	Data Set Ready	CMOS	In	Active low.  Also used to control the power saving mode "stop mode".  See section 2.5 for more information.
17	SerialSelect-0	Serial Select 0	CMOS	Out	Control signal for external serial transceivers. See section A.2.2.4 for more info.
18	SerialSelect-1	Serial Select 1	CMOS	Out	Control signal for external serial transceivers. See section A.2.2.4 for more info.
19-22		Attachment pads			Not electrically connected

\* All signals are logic level UART signals (typically 0 - 3VDC)

\*\* Use 1k $\Omega$  as pull-down which is different to previous product generations from connectBlue



---

## 2.2.4 J7 Connector (Flexfilm)

**Table 5: Signals on J7**

J7 Pin Nr	Pin Name	Signal Name	Signal Level	Type	Description
1	RESET	Hardware reset	CMOS	In	Active low. Must be open drain collector.  See section 2.4 for design examples.
2	DSR	Data Set Ready	CMOS	In	Active low.  Also used to control the power saving mode "stop mode".  See section 2.5 for more information.
3	VSS	Ground	Ground		GND
4	VCC_3V3	Power	3.3V		3.0 – 6.0 VDC for CB-OEMSPA311 modules  3.3 – 6.0 VDC for CB-OEMSPA331 modules
5	DTR	Data Terminal Ready	CMOS	Out	Active low.
6	RED/Mode	Red LED output	CMOS	Out	RED: Logic Red LED Signal (see Chapter 3, Table 14). Active low.  Mode: <b>Not used on cB-0901.</b> This pin is also used to select Logic level mode (instead of RS232) for connectBlue product with internal RS232 driver. To be compatible with these products check the datasheet for these products about this signal.  The pin is not allowed to be pull-down when using the SerialSelect signals.

---

J7 Pin Nr	Pin Name	Signal Name	Signal Level	Type	Description
7	GREEN/ Switch-1	Green LED output and Restore switch	CMOS	In/Out	<p>This signal is multiplexed:</p> <p><b>GREEN:</b> Logic Green LED Signal (see Chapter 3, Table 14). Not valid until 500ms after startup. Active low.</p> <p><b>Switch-1:</b> If the level on this pin is pulled-down with 1k<math>\Omega</math>** the units goes back to default serial settings. The module will restore all factory settings if both the Switch-1 and Switch-0 signals are low during start up.</p> <p>The "Restore Default" input is only active during the first 500ms after startup.</p> <p>See the Serial Port Adapter AT command Specification for more information on the Restore switch.</p> <p>See section A.2.3.2 for design examples.</p>
8	BLUE	Blue LED output	CMOS	Out	<p>Logic Blue LED Signal (see Chapter 3, Table 14). Active low.</p> <p>Note: Signal will flicker at data transmission.</p> <p>See section A.2.3.1 for design examples.</p>
9	UART-TxD*	Transmit Data	CMOS	Out	"0" : Low, "1" : High
10	UART-RxD*	Receive Data	CMOS	In	"0" : Low, "1" : High
11	UART-CTS*	Clear To Send	CMOS	In	Hardware flow control. Active low.
12	UART-RTS*	Request To Send	CMOS	Out	Hardware flow control. Active low.
13-16					Reserved, do not connect.

\* All signals are logic level UART signals (typically 0 - 3VDC)

\*\* Use 1k $\Omega$  as pull-down which is different to previous product generations from connectBlue

---

## 2.2.5 J8 Connector (JST 6-pol)

**Table 6: Signals on J8**

J8 Pin Nr	Pin Name	Signal Name	Signal Level	Type	Description
1	VSS	Ground	Ground		GND
2	VCC_3V3	Power	3.3V		3.0 – 6.0 VDC for CB-OEMSPA311 modules  3.3 – 6.0 VDC for CB-OEMSPA331 modules
3	UART-TxD*	Transmit Data	CMOS	Out	"0" : Low, "1" : High
4	UART-RxD*	Receive Data	CMOS	In	"0" : Low, "1" : High
5	UART-CTS*	Clear To Send	CMOS	In	Hardware flow control. Active low.
6	UART-RTS*	Request To Send	CMOS	Out	Hardware flow control. Active low.

\* All signals are logic level UART signals (typically 0 - 3VDC)

## 2.3 Characteristics

The cB-0901 board is designed to be fully interchangeable. If the host product has space for the board it is possible to choose freely between a cB-OEMSPA311i/x or cB-OEMSPA331i/x device without any change of the host product. If you design your power supply for cB-OEMSPA331i/x the modules will be fully interchangeable.

The cB-0901 module has a linear power supply, which means that the current is constant if the voltage supply is changed. See Table 10.

For more information about low power modes see Serial Port Adapter AT commands Specification.

### 2.3.1 Power supply

**NOTE:** Read the safety notes in section 7.2 before using the modules.

#### 2.3.1.1 cB-OEMSPA311i/x products

**Table 7: Power supply**

Symbol	Parameter	Value	Unit
VCC_3V3	Power supply (Un-regulated*)	Min	3.0 VDC
		Max	6.0 VDC

\* The module is equipped with an internal linear voltage regulator.

**Table 8: Current consumption**

Symbol	Mode	Value	Unit	
$I_{cc}$ @ VCC_3V3 = 3.3V	Not connected	Average	7.9 mA	
		Peak	48 mA	
	Not connected, stop mode enabled	Not connectable	Average	1.0 mA
			Peak	1.2 mA
		Connectable	Average	1.8 mA
			Peak	48 mA
	Connected	Idle or Receiving	Average	17 mA
			Peak	55 mA
		Transmitting @115.2kbit/s	Average	22 mA
			Peak	58 mA
	Inquiry	Average	39 mA	
		Peak	70 mA	

### 2.3.1.2 cB-OEMSPA331i/x products

**Table 9: Power supply**

Symbol	Parameter	Value	Unit
VCC_3V3	Power supply (Un-regulated*)	Min	3.3 VDC
		Max	6.0 VDC

\* The module is equipped with an internal linear voltage regulator.

**Table 10: Current consumption**

Symbol	Mode	Value	Unit	
$I_{cc}$ @ VCC_3V3 = 3.3V	Not connected Stop mode not enabled.	Average	19 mA	
		Peak	63 mA	
	Not connected, stop mode enabled	Not connectable	Average	10 mA
			Peak	13 mA
		Connectable	Average	11 mA
			Peak	60 mA
	Connected	Idle or Receiving	Average	22 mA
			Peak	170 mA
		Transmitting @115.2kbit/s	Average	53 mA
			Peak	170 mA
Inquiry	Average	84 mA		
	Peak	150 mA		

---

## 2.3.2 Input/Output signals

### 2.3.2.1 cB-OEMSPA311i/x products

Table 11: Input/output signals

Symbol	Parameter		Value	Unit
$V_{IN}$ Low	Logic LOW level input voltage on all logic input pins except Switch-0	Min	-0.4	V
		Max	0.80	V
	Logic LOW level input voltage Switch-0	Min	-0.4	V
		Max	0.15	V
$V_{IN}$ High	Logic HIGH level input voltage	Min	2.05	V
		Max	3.35	V
$V_{OUT}$ Low	Logic LOW level output voltage	Max	0.4	V
$V_{OUT}$ High	Logic HIGH level output voltage	Min	2.42	V
$I_{GPIO}$	Sink and source current	Max	4	mA

### 2.3.2.2 cB-OEMSPA331i/x products

Table 12: Input/output signals

Symbol	Parameter		Value	Unit
$V_{IN}$ Low	Logic LOW level input voltage on all logic input pins except Switch-0	Min	-0.4	V
		Max	0.85	V
	Logic LOW level input voltage Switch-0	Min	-0.4	V
		Max	0.15	V
$V_{IN}$ High	Logic HIGH level input voltage	Min	2.15	V
		Max	3.45	V
$V_{OUT}$ Low	Logic LOW level output voltage	Max	0.4	V
$V_{OUT}$ High	Logic HIGH level output voltage	Min	2.55	V
$I_{GPIO}$	Sink and source current	Max	4	mA

---

## 2.3.3 Environmental

**Table 13: Temperatures characteristics**

Parameter		Product Variant	Value	Unit
Storage temperature	Min	All	-40	°C
	Max	All	+125	°C
Maximum operating temperature	Min	CB-OEMSPA311i/x-04	-30	°C
		CB-OEMSPA331i/x-04		
		CB-OEMSPA311i/x-07		
		CB-OEMSPA331i/x-07		
	CB-OEMSPA311i/x-06	-25	°C	
				CB-OEMSPA331i/x-06
Max	CB-OEMSPA311i/x-04	+85	°C	
				CB-OEMSPA331i/x-04
				CB-OEMSPA311i/x-06
				CB-OEMSPA331i/x-06
	CB-OEMSPA311i/x-07	+80	°C	
				CB-OEMSPA331i/x-07

---

---

## 2.4 Hardware Reset

A hardware RESET input is available on the J3, J6 and J7 connectors (see section 2.1). An external reset source must be open drain collector, see section A.2.4 for design examples. The RESET pin is internally pulled-up with 120k $\Omega$ .

## 2.5 Power Control

For more information about "Stop Mode" and other low power modes, see the Serial Port Adapter AT command Specification.



---

## 3 Operating Status

---

The module can be in different modes (see the Serial Port Adapter AT command Specification for more information about the modes) and the RED, GREEN and BLUE signals can be used to detect or indicating the status, see Table 14. The LED signals are active LOW.

**Table 14: Signal states in different module modes**

Serial Port Adapter Mode	Status	RGB LED Color	GREEN GPIO	BLUE GPIO	RED GPIO
Data mode	IDLE	Green	LOW	HIGH	HIGH
AT mode	IDLE	Orange	LOW	HIGH	LOW
Data mode, AT mode	CONNECTING*	Purple	HIGH	LOW	LOW
Data mode, AT mode	CONNECTED*	Blue	HIGH	LOW	HIGH

\* On data activity the active LEDs flashes and will be HIGH for 50-100ms. For information on how to suppress the flashes see section A.2.3.1.

DTR signal can be set to indicate an active Bluetooth link. For more information see Serial Port Adapter AT command Specification.

---

## 4 Antennas

---

There are 2 different antenna options available:

- An internal surface mounted (SMD) antenna.
- An external antenna should be connected to a U.FL connector. Many different external antennas are available.

See section 5.1 for more information on antenna placement.

This chapter gives an overview of the different antenna options.

### 4.1 Surface Mounted Antenna (Internal)

The unit cannot be mounted in a metal-shielded enclosure with this antenna.

Part Number	OEMSPA 311i / 331i
Antenna name	Rufa 2.4 GHz
Manufacture	gigaAnt
Polarization	Linear
Gain (Max)	+0.5 dBi (mounted on this PCB)
Antenna size (LxWxH)	12.8x3.9x1.1 mm
Comment	The antenna gain is very dependent of the mounting of the module. See section 5.4 for mounting the module considering the antenna.



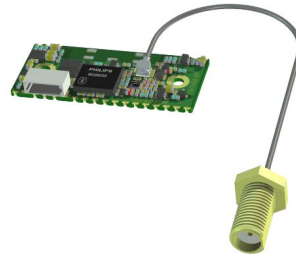
---

## 4.2 External antennas

The external antennas are connected to the board through a U.FL connector. Some of the antennas are connected directly to the U.FL connector of the board and some are connected using an SMA connected through a short U.FL to SMA adapter cable.

### 4.2.1 Antenna Accessories

Part Number	cB-ACC-18
Name	U.FL to SMA adapter cable
Connector	U.FL and SMA female
Cable length	120 mm
Cable loss	Less than 0.5dB

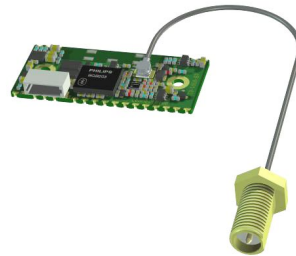


---

Comment	The SMA connector may be mounted in a panel. Not approved for use in the US and Canada.
---------	---

---

Part Number	cB-ACC-38
Name	U.FL to Reverse Polarity SMA adapter cable
Connector	U.FL and reverse polarity SMA male
Cable length	120 mm
Cable loss	Less than 0.5dB



---

Comment	The SMA connector may be mounted in a panel. Approved for use in the US, Canada and Europe.
---------	---

---

---

## 4.2.2 Antennas

Part Number	cB-ACC-16
Name	WCR-2400-SMA
Manufacture	Centurion
Type	½ wave dipole
Polarization	Vertical
Gain	+2.5dBi
Size	100 mm (Straight)
Connector	SMA male



Comment To be mounted on the U.FL to SMA adapter cable.

Approval Not approved for use in the US and Canada.

Part Number	cB-ACC-36
Name	WCR-2400-SMRP
Manufacture	Centurion
Type	½ wave dipole
Polarization	Vertical
Gain	+2.5dBi
Size	100 mm (Straight)
Connector	Reverse Polarity SMA female



Comment To be mounted on the U.FL to reverse polarity SMA adapter cable.

Approval Approved for use in the US, Canada and Europe.

Part Number	cB-ACC-27
Name	WCR-2400-IP04
Manufacture	Centurion
Type	½ wave dipole
Polarization	Vertical
Gain	+2.0dBi
Size	108 mm (Straight)
Connector	U.FL connector



Comment To be mounted on the U.FL connector on the PCB.

Approval Approved for use in the US and Canada

Part Number	cB-ACC-17
Name	Reel planTec Blue-tooth m70
Manufacture	Reel
Size (ØxH)	75x20 mm
Gain	+1dBi
Mounting	M16x13.6 mm
Cable length	3 m
Connector	SMA male
Other info	Waterproof (IP67)
Comment	To be mounted on the U.FL to SMA adapter cable.
Approval	Not approved for use in the US and Canada.



Part Number	cB-ACC-23
Name	Mobile Mark Stub
Manufacture	Mobile Mark Communications Antennas
Type	¼ wave dipole
Polarization	Vertical
Gain	0dBi
Connector	SMA male
Comment	To be mounted on the U.FL to SMA adapter cable
Approval	Not approved for use in the US and Canada.



Part Number	cB-ACC-21
Name	Rugged SMA
Manufacture	Radiall/Larsen
Type	½ wave dipole
Polarization	Vertical
Gain	2dBi
Connector	SMA male
Comment	To be mounted on the U.FL to SMA adapter cable
Approval	Not approved for use in the US and Canada.



# 5 Mounting Information

## 5.1 Board Outlines

### 5.1.1 cB-0901

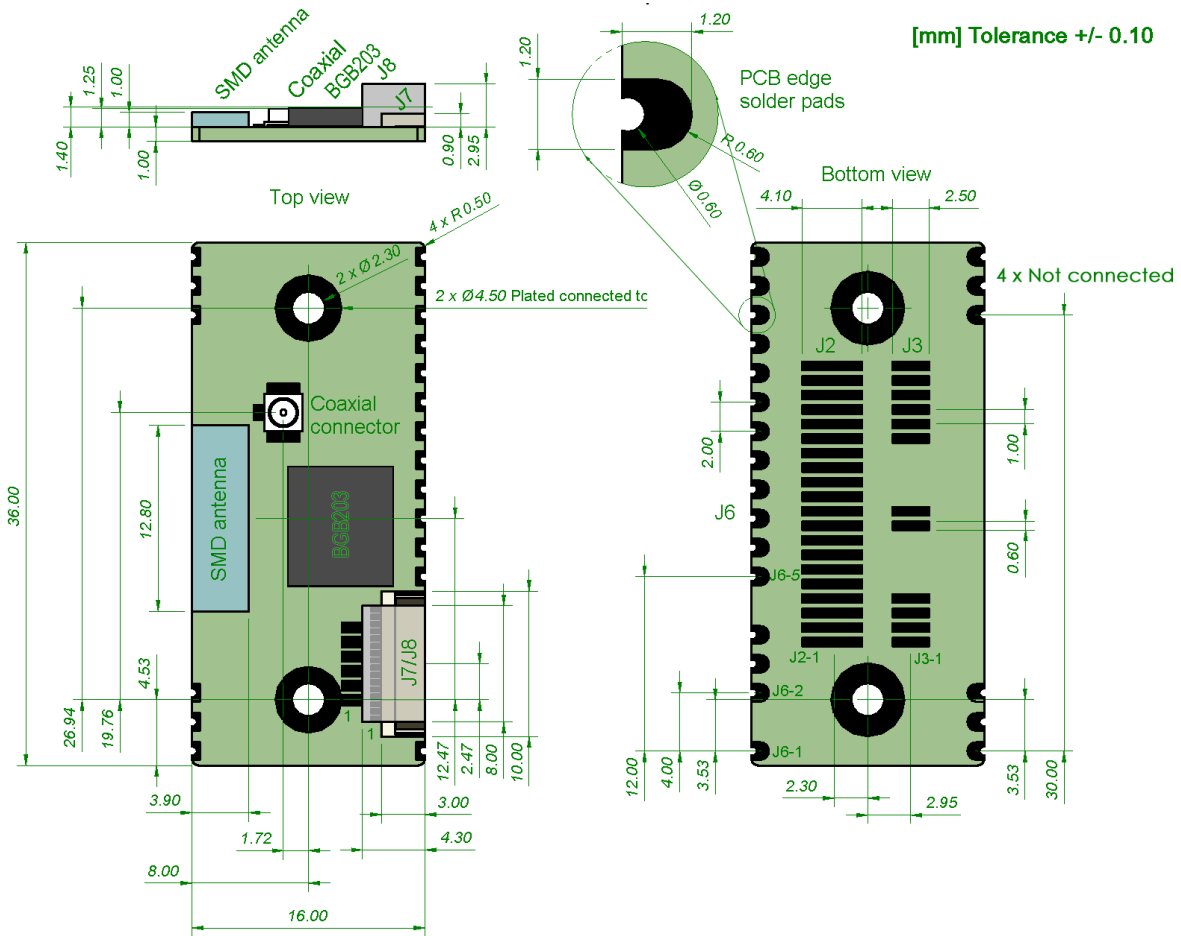


Figure 5: cB-0901 dimensions [mm]. The J2 pads are longer to fit both the single and double row ASP connectors (see section 5.2). Some of the not used pads of J3 are not visible

## 5.1.2 Mounting Holes

There are 2 x 2.3mm mounting holes on cB-0901. The reasons for the 2.3mm holes are that the threaded M2 holes on the single and double row connectors (see section 5.2.1) are not aligned. The outer tangents of the 2.3mm holes align the module if the single row connectors are used and the inner if double row connectors are used (see Figure 6).

Choose the outer tangent (CC distance 27.24mm) if the module is aligned and mounted with some other technique based on M2 screws (e.g. press-fit nuts), see Figure 7 and Figure 8.

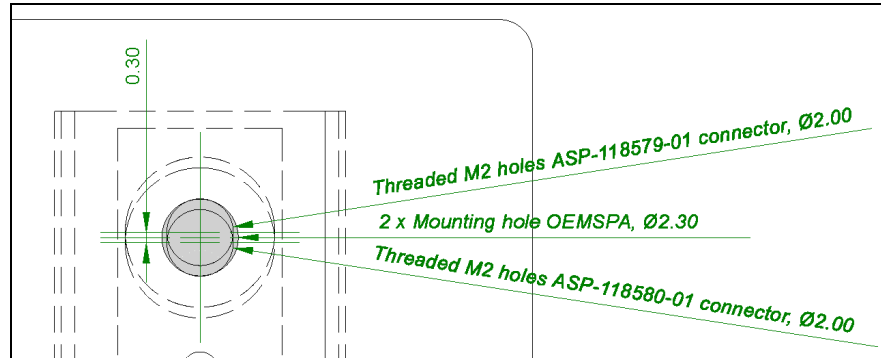


Figure 6: The 2.3mm mounting holes [mm]

---

## 5.2 Using the J2/J3 Board-to-Board Connectors

The board-to-board connector should be a 1mm pitch one-piece part connector. The recommended manufacture is Samtec with many connector options available; see section 5.2.1.1 and 5.2.1.2.

Chapter 2 contains more information about the connector and the electrical interface.

### 5.2.1 Suitable One-Piece Part Connectors

#### 5.2.1.1 Single row connectors

These connectors are a single row connector and can be used if only J2 is needed.

This connector has a profile height of 1.65 mm and this has to be considered if components are to be mounted on the motherboard under the OEM Serial Port Adapter board.

There are alignment pins on the bottom side of the connector.

The connector is available with M2 threaded inserts that fit the mounting holes on the board (see section 5.1.2). You may screw the OEM Serial Port Adapter board directly into these inserts. If you want to have a tighter and more secure mounting, you may use longer screws and secure it using a nut on the backside of the motherboard.

Another way to mount the module is to use press-fit nuts on the motherboard and skip the M2 threads on the connector, see section 5.3 for more information about press-fit nuts.

**Table 15: Single row connectors from Samtec.**

Samtec order number	Quote number	Equivalent part	Package	Remark
ASP-118645-01	55392	SEI-120-02-GF-S-AB	Tube	Align pin on bottom side only
ASP-118645-02	55392	SEI-120-02-GF-S-AB-TR	Tape-n-Reel	Align pin on bottom side only
ASP-118579-01	55392	SEI-120-02-GF-S-M-AB	Tube	With M2 threaded inserts and align pin on bottom side only
ASP-118579-02	55392	SEI-120-02-GF-S-M-AB-TR	Tape-n-Reel	With M2 threaded inserts and align pin on bottom side only

**NOTE:**

When ordering connectors from Samtec or an official Samtec distributor, please use the ASP order number and refer to the connectBlue global quote number for best price. For technical questions regarding the Samtec connectors please contact connectBlue or Samtec at ([Scandinavia@samtec.com](mailto:Scandinavia@samtec.com)).

See Figure 7 for more information about the connector and necessary measurements on the motherboard. The large mounting holes on the motherboard are designed for press-fit nuts and could be smaller if press-fit nuts are not used. The mounting holes are aligned with the outer tangent of the 2.3mm mounting holes of the module (see section 5.1.2).



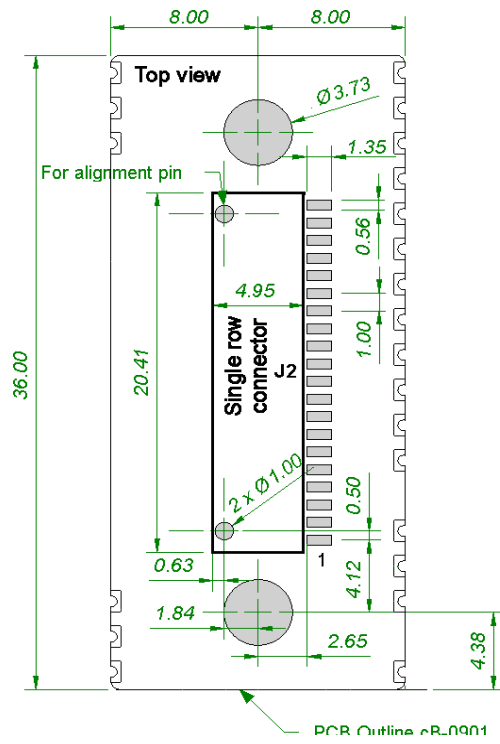


Figure 7: Host PCB layout [mm] for single row connector.

---

### 5.2.1.2 Double row connectors

This connector is a double row connector and can be used if both J2 and J3 are needed.

This connector has a height of 3.0mm and this has to be considered if components are to be mounted on the motherboard under the OEM Serial Port Adapter board. The connector is also available with a height of 6.0mm and 10.0mm (The FSI-120 serie from Samtec).

There are alignment pins on the bottom side of the connector.

The connector is available with M2 threaded inserts that fit the mounting holes on the board (see section 5.1.2). You may screw the OEM Serial Port Adapter board directly into these inserts. If you want to have a tighter and more secure mounting you may use longer screws and secure it using a nut on the backside of the motherboard.

Another way to mount the module is to use press-fit nuts on the motherboard and skip the M2 threads on the connector, see section 5.3 for more information about press-fit nuts.

**Table 16: Double row connectors from Samtec.**

Samtec order number	Quote number	Equivalent part	Package	Remark
REF-120021-01	55392	FSI-120-03-G-D-AB	Tube	Align pin on bottom side only
REF-120021-02	55392	FSI-120-03-G-D-AB-K-TR	Tape-n-Reel	Align pin on bottom side only
REF-120018-01	55392	FSI-120-03-G-D-M-AB	Tube	With M2 threaded inserts and align pin on bottom side only
REF-120018-02	55392	FSI-120-03-G-D-M-AB-K-TR	Tape-n-Reel	With M2 threaded inserts and align pin on bottom side only

**NOTE:**

When ordering connectors from Samtec or an official Samtec distributor, please use the REF order number and refer to the connectBlue global quote number for best price. For technical questions regarding the Samtec connectors please contact connectBlue or Samtec at ([Scandinavia@samtec.com](mailto:Scandinavia@samtec.com)).

See Figure 8 for more information about the connector and necessary measurements on the motherboard. The large mounting holes on the motherboard are designed for press-fit nuts and could be smaller if press-fit nuts are not used (see section 5.1.2).

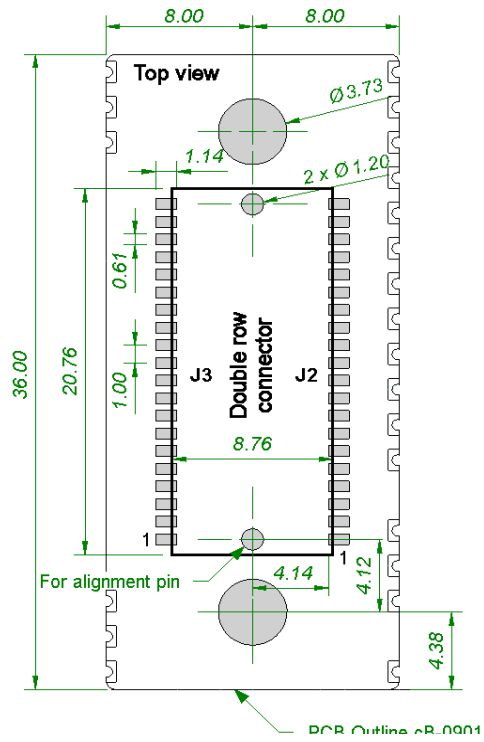
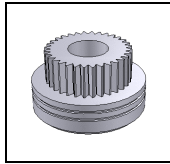


Figure 8: Host PCB layout [mm] for double row connector.

---

## 5.3 Using Press-Fit Nuts for Mounting the Module

A press-fit nut is pressed into the PCB from the bottom side with a special press tool. M2 sized press-fit nuts are suitable for the modules (see Figure 7 and Figure 8) and are manufactured by PEM Fastening Systems ([www.pemnet.com](http://www.pemnet.com)), part no KFS2-M2 (see Figure 9). Be careful with the distance between the nuts regarding alignment, see section 5.1.2.



**Figure 9: KFS2-M2 press-fit nut.**

Spacer-pipes are recommended to use between the PCBs when press-fit nuts are used.

## 5.4 Using the J6 PCB solder pads on the edge

### 5.4.1 Host PCB

The host PCB footprint should not contain any traces or vias under the module except the pads interfacing the J6 pads to avoid contact with traces/vias on the module. The host pads which are soldered to the J6 pads should reach 0.5-1.0mm under the PCB and some mm outside the module. No other pads than the J6 should be soldered to the host PCB. See section 2.1.1 for more info about the J6 pads.

### 5.4.2 Mounting process

- We strongly recommend the modules not being soldered more than 1 time after shipping from connectBlue and that the modules are mounted just before the host product is being soldered the last time. Although, connectBlue devices will withstand up to two reflows to an absolute maximum temperature of 250°C.
- The PCB in our modules is made of FR4-type with Chemical Gold Pads.
- The modules are produced in a lead-free process with a lead-free soldering paste.
- It is recommended that the customers make their own electrical, climate, stress and vibration tests on the final assembled product to secure that the manufacturing process hasn't damaged or affected the Bluetooth module in any way.
- The modules can be delivered on trays or individually packed in ESD bags with label on each module. The label will not withstand the heat of soldering and should be removed before processed. The modules delivered in trays will not have individual label (only batch labels on the tray).
- Modules delivered on trays are classed with MSL-Class 3.
- The device recommended maximum reflow temperature is 245°C for 10 sec.
- The device absolute maximum reflow temperature is 250°C for 3 sec.

## 5.5 Antenna Issues

The unit cannot be mounted arbitrary, because of the radio communication. The unit with an internal surface mounted antenna (CB-OEMSPA311i and CB-OEMSPA331i) cannot be mounted in a metal enclosure, see Figure 10.

No metal casing or plastics using metal flakes should be used, avoid also metallic based paint or lacquer. Keep a minimum clearance of 10mm between the antenna and the casing. Keep 10 mm free space from metal around the antenna including under and above.

If a metal enclosure is required, one of the external antenna options has to be used. See section 4.2 for more information on the antenna options available.

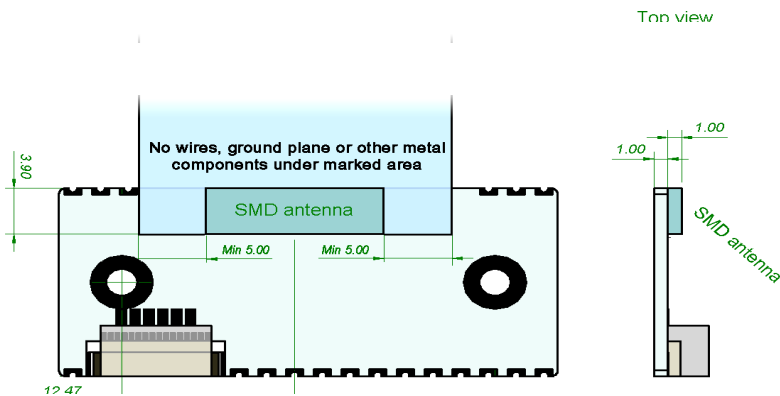


Figure 10: SMD Antenna restrictions.

---

## 6 Bluetooth Information

---

### 6.1 General information

In the tables below you can find information about Bluetooth properties. The cB-0901 module is available in two output power versions both Bluetooth Class 1. The output power of the cB-OEMSPA311i/x device is max +7dBm (5mW) and the output power of the cB-OEMSPA331i/x device is max +16.9dBm (49mW).

**Table 17: Bluetooth information CB-OEMSPA-311i/x**

Parameter	Data
Bluetooth radio	Philips BGB203
Bluetooth base band controller	Philips BGB203
RF output power	Class 1, max 7dBm (5mW)
Receive sensitive level	-90dBm
Receive input level (max)	+15dBm
Output frequency	2.402 –2.480 GHz, ISM band.
Bluetooth stack	Embedded host stack
Bluetooth qualification	2.0

**Table 18: Bluetooth information CB-OEMSPA-331i/x)**

Parameter	Data
Bluetooth radio	Phillips BGB203
Bluetooth base band controller	Phillips BGB203
Radio power amplifier	muRata MF2400PS-AL0909 (+20dB)
RF output power	Class 1, max 16.9dBm (49mW)
Receive sensitive level	-89dBm
Receive input level (max)	+16dBm
Output frequency	2.402 –2.480 GHz, ISM band.
Bluetooth stack	Embedded host stack
Bluetooth qualification	2.0

---

## 6.2 Bluetooth Qualification information



All products based on the PCB cB-0901-03 have been qualified according to the Bluetooth specification 2.0.

**Table 19 - Bluetooth Qualification information**

Module	Bluetooth specification	QD ID	List date
cB-OEMSPA311i /x	2.0	B010797	2007-01-24
cB-OEMSPA331i/x	2.0	B010798	2007-01-24

The following Bluetooth profiles are supported (covered functionality):

- Generic Access Profile (GAP)
- Serial Port Profile (SPP)
- Dial-up Networking Profile (DUN GW, DUN DT)

When creating end products based on the Serial Port Adapter the following applies:

- The end product does not have to be re-qualified.
- A free of charge *Bluetooth* End Product Listing (EPL) **must** be completed at the Bluetooth SIG website [www.bluetooth.org](http://www.bluetooth.org). This applies for all products implementing *Bluetooth* technology. The EPL requires no testing (online listing only) and is good marketing since the product is published at the *Bluetooth* web site [www.bluetooth.com](http://www.bluetooth.com). When creating the EPL you shall refer to the Qualified Design ID (QDID) of the connectBlue module. Easy-to-follow EPL guides are available at [www.bluetooth.org](http://www.bluetooth.org) to assist you with the EPL. A free of charge "Bluetooth SIG Adopter membership" is required.
- The *Bluetooth* trademark may be placed on the end product and/or used in material related to the end product. This requires a free of charge "Bluetooth SIG Adopter membership". For more information see [www.bluetooth.org](http://www.bluetooth.org).

For more information please contact connectBlue.

---

# 7 Regulatory Information

---

## 7.1 Declaration of Conformity



We, **connectBlue AB**, of  
**Norra Vallgatan 64 3V**  
**SE-211 22 Malmö, Sweden**

declare under our sole responsibility that our products:

cB-OEMSPA311i/x (cB-0052, cB-0054, cB-0055, cB-0056, cB-0058, cB-0059),  
cB-OEMSPA331i/x (cB-0060, cB-0062, cB-0063, cB-0064, cB-0066, cB-0067),  
cB-OEMHCI311i/x (cB-0086, cB-0087), cB-OEMHCI331i/x (cB-0088, cB-0089),  
OEM Module Adapter III (cB-0068).

to which this declaration relates, conforms to the following product specifications:

**R&TTE Directive 1999/5/EC**

EN 300 328 V1.7.1 (2006-10)

**EMC**

EN 301 489-1 V1.8.1 (2008-04)

EN 301 489-17 V1.3.2 (2008-04)

EN 61000-6-2 (2005)

**Safety Compliance**

EN 60950-1:2006 and/or IEC 60950-1:2005 (2nd Edition)

**Medical Electrical Equipment**

IEC 60601-1-2 (2001)

2009-12-08 Malmö, Sweden

Mats Andersson

*CTO of connectBlue AB*

If a cB-OEMSPA331i/x is used within EU a notification must be made to each of the **national authorities** responsible for radio spectrum management of the intention to place radio equipment that uses frequency bands whose use is not harmonized throughout the EU, on its national market.

More information at: <http://europa.eu.int/comm/enterprise/rtte/gener.htm>



---

## 7.2 Safety Compliance

In order to fulfill the safety standard EN 60950-1 the unit must be supplied by a limited power source.

## 7.3 FCC and IC Compliance

See Table 1 for information about the different product variants.

### 7.3.1 Compliance for cB-0901-0301

#### 7.3.1.1 FCC Statement for cB-0901-0301

This device complies with Part 15 of the FCC Rules. Operation is subject to the following two conditions: (1) this device may not cause harmful interference, and (2) this device must accept any interference received, including interference that may cause undesired operation.

**NOTE:** This equipment has been tested and found to comply with the limits for a Class B digital device, pursuant to Part 15 of the FCC Rules. These limits are designed to provide reasonable protection against harmful interference in a residential installation. This equipment generates, uses and can radiate radio frequency energy and, if not installed and used in accordance with the instructions, may cause harmful interference to radio communications. However, there is no guarantee that interference will not occur in a particular installation. If this equipment does cause harmful interference to radio or television reception, which can be determined by turning the equipment off and on, the user is encouraged to try to correct the interference by one or more of the following measures:

- Reorient or relocate the receiving antenna
- Increase the separation between the equipment and receiver
- Connect the equipment into an outlet on a circuit different from that to which the receiver is connected

Consult the dealer or an experienced radio/TV technician for help

#### 7.3.1.1.1 Antenna

Our module type cB-0901-0301 is for OEM integrations only. The end-user product will be professionally installed in such a manner that only the authorized antennas are used.

#### 7.3.1.1.2 Caution

Any changes or modifications NOT explicitly APPROVED by connectBlue AB could cause the module to cease to comply with FCC rules part 15, and thus void the user's authority to operate the equipment.

#### 7.3.1.2 IC Compliance

Operation is subject to the following two conditions:

- (1) this device may not cause harmful interference, and
  - (2) this device must accept any interference received,
- including interference that may cause undesired operation.

This device has been designed to operate with an antenna having a maximum gain of 2.5 dBi.

Having a higher gain is strictly prohibited per regulations of Industry Canada. The required antenna impedance is 50 ohms.

---

To reduce potential radio interference to other users, the antenna type and its gain should be so chosen that the equivalent isotropically radiated power (EIRP) is not more than that required for successful communication.

The installer of this radio equipment must ensure that the antenna is located or pointed such that it does not emit RF field in excess of Health Canada limits for the general population; consult Safety Code 6, obtainable from Health Canada's website [www.hc-sc.gc.ca/rpb](http://www.hc-sc.gc.ca/rpb).

### **7.3.1.3 Labeling Requirements for End Product**

For an end product using the product cB-0901-0301 there must be a label containing, at least, the following information:

This device contains FCC ID: PVH090103S IC: 5325A-090103S
---

The label must be affixed on an exterior surface of the end product such that it will be visible upon inspection in compliance with the modular approval guidelines developed by the FCC.

In accordance with 47 CFR § 15.19 the end product shall bear the following statement in a conspicuous location on the device:

"This device complies with Part 15 of the FCC Rules.

Operation is subject to the following two conditions:

- (1) this device may not cause harmful interference, and
- (2) this device must accept any interference received, including interference that may cause undesired operation."

When the device is so small or for such use that it is not practicable to place the statement above on it, the information shall be placed in a prominent location in the instruction manual or pamphlet supplied to the user or, alternatively, shall be placed on the container in which the device is marketed. However, the FCC ID label must be displayed on the device.

In case, where the final product will be installed in locations where the end-user is not able to see the FCC ID and/or this statement, the FCC ID and the statement shall also be included in the end-product manual.

---

## 7.3.2 Compliance for cB-0901-0302

### 7.3.2.1 FCC Statement for cB-0901-0302

This device complies with Part 15 of the FCC Rules. Operation is subject to the following two conditions: (1) this device may not cause harmful interference, and (2) this device must accept any interference received, including interference that may cause undesired operation.

**NOTE:** This equipment has been tested and found to comply with the limits for a Class B digital device, pursuant to Part 15 of the FCC Rules. These limits are designed to provide reasonable protection against harmful interference in a residential installation. This equipment generates, uses and can radiate radio frequency energy and, if not installed and used in accordance with the instructions, may cause harmful interference to radio communications. However, there is no guarantee that interference will not occur in a particular installation. If this equipment does cause harmful interference to radio or television reception, which can be determined by turning the equipment off and on, the user is encouraged to try to correct the interference by one or more of the following measures:

- Reorient or relocate the receiving antenna
- Increase the separation between the equipment and receiver
- Connect the equipment into an outlet on a circuit different from that to which the receiver is connected

Consult the dealer or an experienced radio/TV technician for help

#### 7.3.2.1.1 Antenna

Our module type cB-0901-0302 is for OEM integrations only. The end-user product will be professionally installed in such a manner that only the authorized antennas are used.

#### 7.3.2.1.2 Caution

Any changes or modifications NOT explicitly APPROVED by connectBlue AB could cause the module to cease to comply with FCC rules part 15, and thus void the user's authority to operate the equipment.

### 7.3.2.2 IC Compliance

Operation is subject to the following two conditions:

- (1) this device may not cause harmful interference, and
- (2) this device must accept any interference received,

including interference that may cause undesired operation.

This device has been designed to operate with an antenna having a maximum gain of 9dBi.

Having a higher gain is strictly prohibited per regulations of Industry Canada. The required antenna impedance is 50 ohms.

To reduce potential radio interference to other users, the antenna type and its gain should be so chosen that the equivalent isotropically radiated power (EIRP) is not more than that required for successful communication.

The installer of this radio equipment must ensure that the antenna is located or pointed such that it does not emit RF field in excess of Health Canada limits for the general population; consult Safety Code 6, obtainable from Health Canada's website [www.hc-sc.gc.ca/rpb](http://www.hc-sc.gc.ca/rpb).

---

### 7.3.2.3 Labeling Requirements for End Product

For an end product using the product cB-0901-0302 there must be a label containing, at least, the following information:

This device contains  
FCC ID: PVH090103L  
IC: 5325A-090103L

The label must be affixed on an exterior surface of the end product such that it will be visible upon inspection in compliance with the modular approval guidelines developed by the FCC.

In accordance with 47 CFR § 15.19 the end product shall bear the following statement in a conspicuous location on the device:

“This device complies with Part 15 of the FCC Rules.

Operation is subject to the following two conditions:

- (1) this device may not cause harmful interference, and
- (2) this device must accept any interference received, including interference that may cause undesired operation.”

When the device is so small or for such use that it is not practicable to place the statement above on it, the information shall be placed in a prominent location in the instruction manual or pamphlet supplied to the user or, alternatively, shall be placed on the container in which the device is marketed. However, the FCC ID label must be displayed on the device.

In case, where the final product will be installed in locations where the end-user is not able to see the FCC ID and/or this statement, the FCC ID and the statement shall also be included in the end-product manual.

### 7.3.2.4 RF-exposure Statement for cB-0901-0302

This modular transmitter MUST have a separation distance of at least 20 cm between the antenna and the body of the user or nearby persons, excluding hands, wrists, feet, and ankles.

If the radio module is installed in a laptop display, transmission MUST be prevented if the lid is closed to ensure that the minimum distance of 20 cm between the user and the transmitting antenna is maintained.

Any notification to the end user of installation or removal instructions about the integrated radio module is NOT allowed.

## 7.4 Japanese Approval Certificate for cB-0901-0301

cB-0901-0301 is approved for Japan with a Japanese Approval Certificate for Radio Equipment. Before using the product in Japan connectBlue must be contacted for further details.

---

## 7.5 UL listing information

If a customer intends to UL list a product including any of the Bluetooth modules based on the PCB cB-0901-03 this information is useful:

The printed circuit board if produced according to the following specification:

- UL recognized ZPMV2 min. 105 °C flame class V-0 or better.

## 7.6 Compliance with RoHS directive



All products based on the PCB cB-0901-03 are produced according to the RoHS (Restriction of the use of certain Hazardous Substances in electrical and electronic equipment) directive and complies with the directive.

---

## 8 Guidelines for Efficient and Safe Use

---

### 8.1 General

Read this information before using your OEM Serial Port Adapter.

For any exceptions, due to national requirements or limitations, when using your OEM Serial Port Adapter, please visit [www.bluetooth.org](http://www.bluetooth.org).

---

***Note: Changes or modifications to the product not expressly approved by connectBlue AB will void the user's authority to operate the equipment.***

---

### 8.2 Product Care

- Do not expose your product to liquid or moisture.
- Do not expose your product to extreme hot or cold temperature (see Section 2.3.3 for further information).
- Do not expose your product to lit candles, cigarettes, cigars, open flames, etc.
- Do not drop, throw or try to bend your product since rough treatment could damage your product.
- Do not attempt to disassemble your product. Doing so will void warranty. The product does not contain consumer serviceable or replaceable components. Service should only be performed by connectBlue AB.
- Do not paint your product as the paint could prevent normal use.
- If you will not be using your product for a while, store it in a place that is dry, free from damp, dust and extreme heat and cold.
- The clearance and creepage distances required by the end product must be withheld when the module is installed.
- The cooling of the end product shall not negatively be influenced by the installation of the module when the module is installed.

### 8.3 Radio Frequency Exposure

The OEM Serial Port Adapter contains a small radio transmitter and receiver. During communication with other Bluetooth products the OEM Serial Port Adapter receives and transmits radio frequency (RF) electromagnetic fields (microwaves) in the frequency range 2400 to 2500 MHz. The output power of the radio transmitter is very low.

When using the OEM Serial Port Adapter, you will be exposed to some of the transmitted RF energy. This exposure is well below the prescribed limits in all national and international RF safety standards and regulations.

---

## 8.4 Electronic Equipment

Most modern electronic equipment, for example, in hospitals and cars, is shielded from RF energy. However, certain electronic equipment is not. Therefore:

**Note:** This equipment emits RF energy in the ISM (Industrial, Scientific, Medical) band. Please insure that all medical devices used in proximity to this device meet appropriate susceptibility specifications for this type of RF energy.

## 8.5 Potentially Explosive Atmospheres

Turn off your electronic device before entering an area with potentially explosive atmosphere. It is rare, but your electronic device could generate sparks. Sparks in such areas could cause an explosion or fire resulting in bodily injury or even death.

Areas with a potentially explosive atmosphere are often, but not always, clearly marked. They include fuelling areas, such as petrol station, below deck on boats, fuel or chemical transfer or storage facilities, and areas where the air contains chemicals or particles, such as grain, dust, or metal powders.

## 8.6 Power Supply

The OEM Serial Port Adapter must be supplied by a limited power source according to EN 60950-1.

- Connect your power supply only to designated power-sources as marked on the product.
- Make sure all cords and cable are positioned so that they will not be stepped on, tripped over or otherwise subject to damage or stress.
- To reduce risk of electric shock, unplug the unit from any power source before attempting to clean it.

---

# Appendix A - Application Notes

Usually only a subset of the available functionality is of interest to the designer. In addition, depending on the host system, the electrical interface can be designed in many ways. The designer can use the step-by-step guide in this chapter as an aid in the design process.

## A.1 Step-by-Step Guide

**Table 20: Step-by-step guide with Yes and No answers.**

Question	Yes	No
Are you going to integrate the OEM Serial Port Adapter in a metal enclosure?	The internal antenna models cannot be used. Use the OEMSPA311x or OEMSPA331x.	You are free to choose between the products. The internal antenna models are lower cost and are easier to design-in. However, an external antenna could give better range.
Do you wish to use logic level when communicating with the OEM Serial Port Adapter?	See section A.2.2.1 for electrical design.	See section A.2.2.2 - A.2.2.3 for electrical design.
Do you want to use RS232 as the physical serial interface?	See section A.2.2.2 for electrical design.	Go on to next point.
Do you want to use RS485 or RS422 as the physical serial interface?	See section A.2.2.3 - A.2.2.4 for electrical design.	Go on to next point.
Is low power consumption important?	The power consumption can be reduced by enabling the stop mode, see Table 10. The stop mode is controlled with the DSR pin, see section 2.5. The power consumption is optimized with 3.2-3.3 V supply voltage.	Go on to next point.
Do you wish to connect LEDs to the OEM Serial Port Adapter?	See section A.2.3 for design examples for connecting the LEDs.	Go on to next point.
Do you want to detect the status of the module with a controller?	See Chapter 3, Table 14 for status detection and section A.2.3 for electrical design.	Go on to next point.
Do you wish to utilize the restore switch?	See section A.2.3.2 for electrical design.	Go on to next point.
Do you wish to utilize the Function switch ("Connect on external signal")?	See section A.2.3.4 for electrical design.	Go on to next point.
Do you want to manually reset the module?	See section A.2.4 for electrical design. Use a double row connector. See section 5.2.1.2.	



## A.2 Design Examples

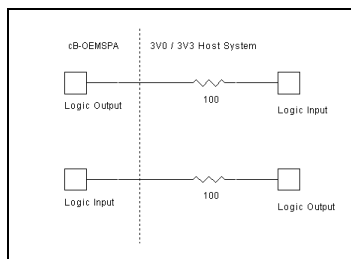
This section contains design examples for all interfaces on J2, J3, J6, J7 and J8. The connector type that suits a specific application depends on the needed signal and the preferred interface type (wires, flexfilm, board-to-board or SMD).

### A.2.1 Logic Levels

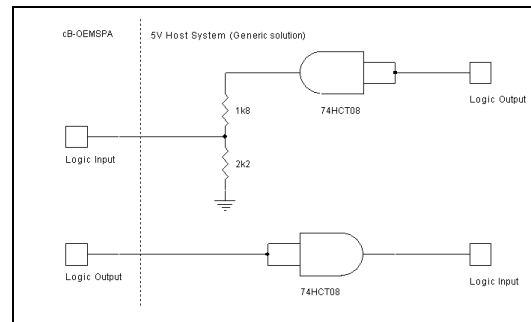
A 3.0/3.3V host system can be connected directly to the logic level pins (BLUE, UART-TxD / UART-RxD etc). A serial  $100\Omega$  resistor shall be used (see Figure 11) for protection, see Table 12 for logic levels characteristics.

A 5V host system can easily be adjusted to the logic levels. A host system output signal can use a resistive divider ( $1.8k\Omega/2.2k\Omega$ ) to adjust the levels. This is applicable for speeds up to 115.2kBits/s. The divider can be improved by adding a logic buffer (74HCT08) for higher speeds (see Figure 12). The host system input pins could require a buffer (see Figure 12) depending on the logic level requirements (see Table 12).

The 74HCT08 gate is also available in a single gate package (74AHCT1G08).

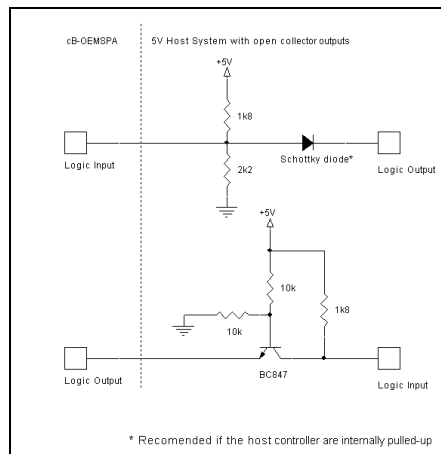


**Figure 11: Logic levels interface to a 3/3.3V system. A protective  $100\Omega$  resistor is used.**



**Figure 12: Interface example with logic levels to a 5V system.**

A 5V system with open collector outputs is designed in Figure 13.



**Figure 13: Open collector outputs.**

## A.2.2 Serial Interface

The serial interface of the module is Logic Level logic levels and the module can be connected to an external CPU (see section A.2.2.1).

An external driver is needed if the module should be on another physical interface like RS232 or RS485/RS422 (see section A.2.2.2 - A.2.2.4).

CTS (Clear To Send) and RTS (Request To Send) are used for hardware flow control.

DSR (Data Set Ready) can be used to make a connect attempt. See the Serial Port Adapter AT commands specification.

DTR (Data Terminal Ready) can be used to detect if the module is up and running and ready to receive data.

**Note! The module must be configured to flow control none if hardware flow control is not used, see the Serial Port Adapter AT Commands specification for more info.**

### A.2.2.1 Logic level Mode

The serial UART interface can be used in a host controller application with a UART interface. The design of the interface depends on the power supply voltage of the host system; see Figure 14 for a 3.0/3.3V host system and Figure 15 for a 5V host system.

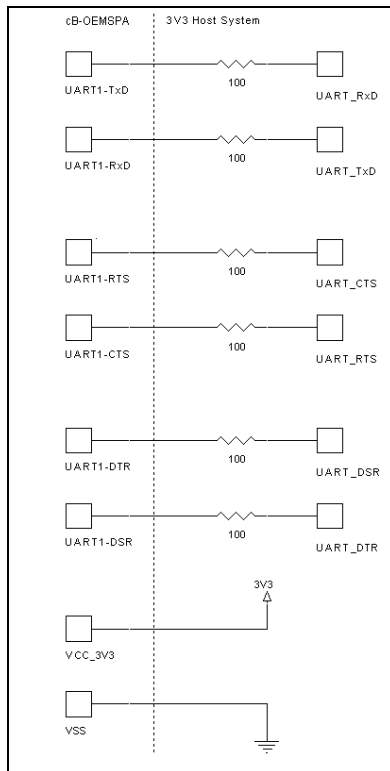


Figure 14: A complete UART interface with a 3.0/3.3V host system.

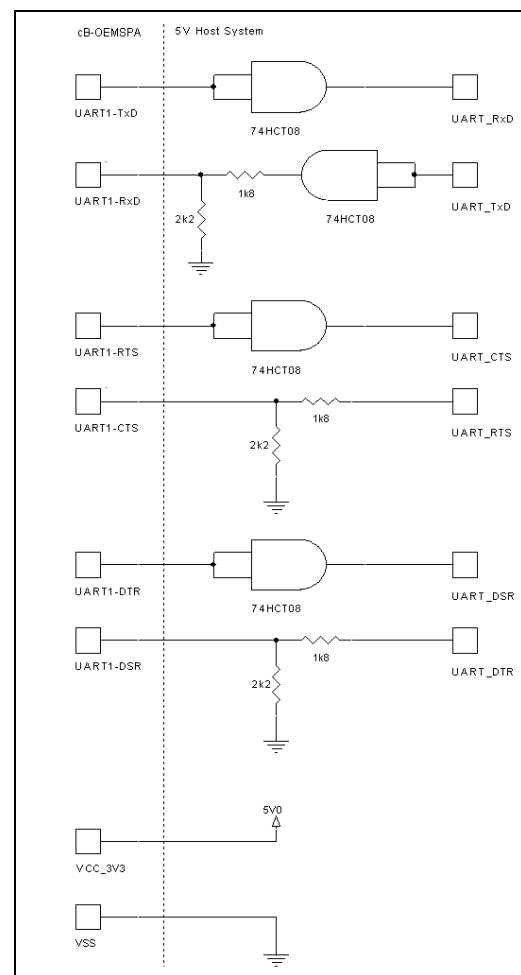


Figure 15: A complete UART interface with a 5V host system.

### A.2.2.2 External RS232 driver

An external RS232 driver is needed if the module should have a RS232 serial interface. See Figure 16 for a complete design example that could be connected to the serial port of standard PC. Not used functionality can be left unconnected; see section A.2.2.

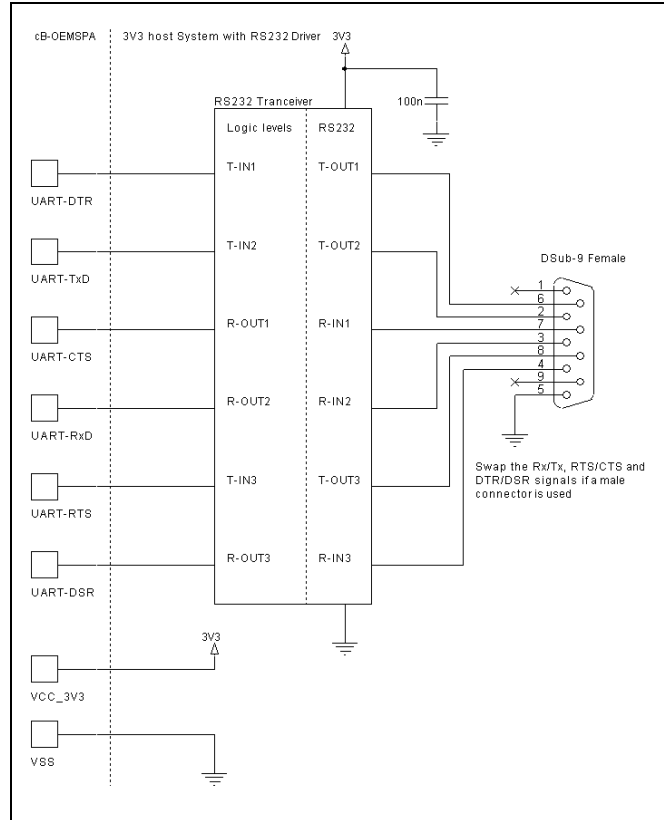


Figure 16: A complete RS232 interface.

### A.2.2.3 External RS422 driver

An external RS422 driver could be used in a point-to-point (full duplex) application (see Figure 17).

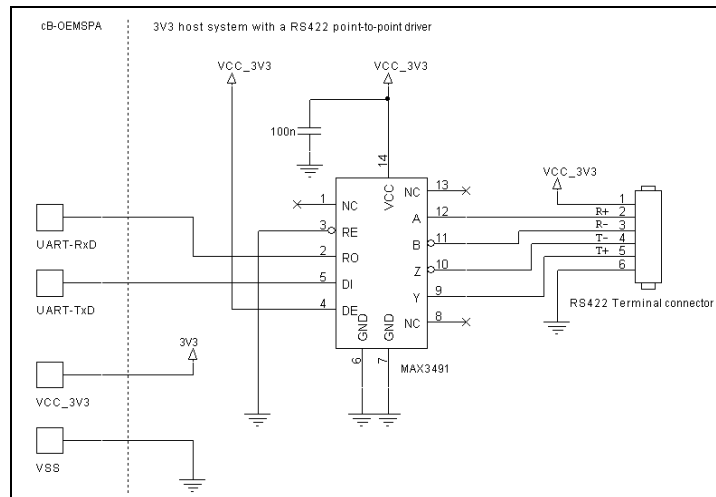


Figure 17: A complete RS422 interface.

### A.2.2.4 External RS422/RS485 transceiver

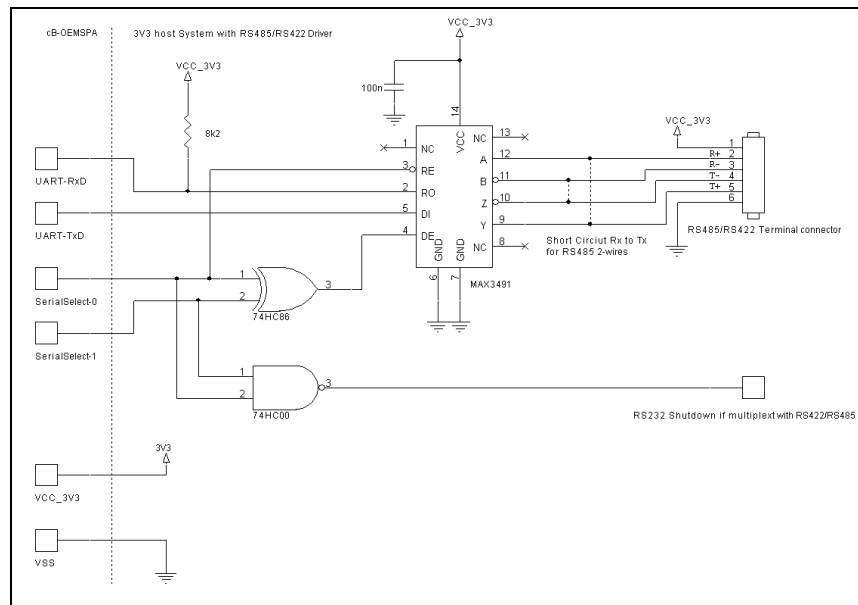
A complete RS422/RS485 transceiver design connected to a bus system need to control the enable signals of the transceiver. The SerialSelect signals are used for this purpose (see Table 21).

The module need to be software configured to the corrected interface, see the Serial Port Adapter AT Commands document how to configure the module to the correct serial interface.

The Red/Mode pin is not allowed to be pull-down when using the SerialSelect signals (see section 2.2).

**Table 21: SerialSelect signals combinations**

Serial Select-0	Serial Select-1	RS485/RS422 Transmitter status (Active high)	RS485/RS422 Receiver status (Active low)
0	0	Disabled	Enabled
0	1	Enabled	Enabled
1	0	Enabled	Disabled
1	1	Disabled	Disabled



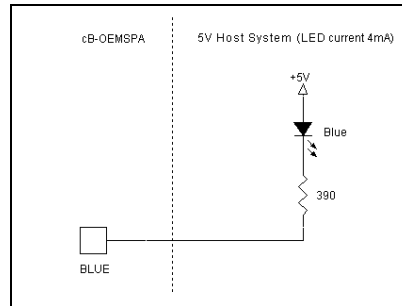
**Figure 18: A complete RS422/RS485 transceiver design.**

## A.2.3 LED and Switch Design

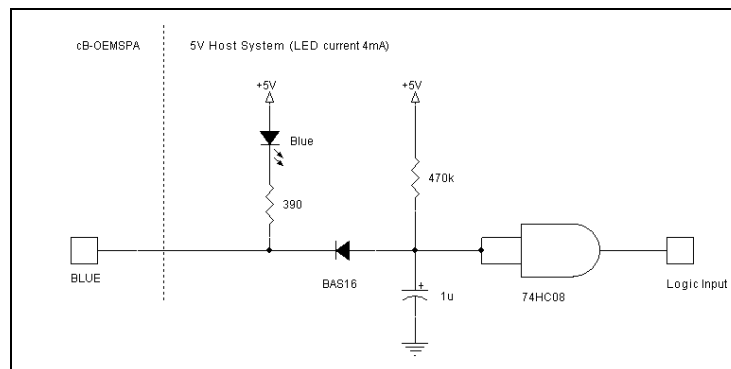
### A.2.3.1 BLUE Signal

The BLUE logic LED signal is not multiplexed with any other functionality, which makes the design more straightforward (for more information see Figure 19). There are two important notes:

- A blue LED requires about 3.5V forward voltage drop (cannot be used in a 3.3V system).
- The BLUE signal can be used to detect if the module is connected or not. The BLUE signal flashes when the module is sending and receiving data (see Chapter 3, Table 14). See Figure 20 for an example on how to suppress the flashes.



**Figure 19:** A blue LED can be connected directly to the module if the LED current is below 4mA. A high state (active low) makes the voltage drop over the LED to 2.2V. This is not enough to light the LED.



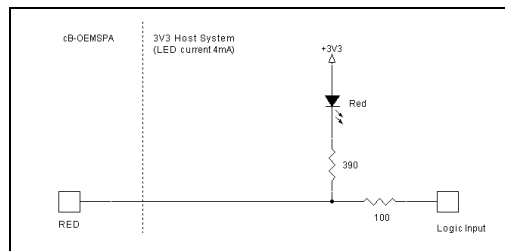
**Figure 20:** A Low pass filter and a 74HC08 suppress the flashes when the module is sending and receiving data. The Blue LED can be removed if not required. The values are not suited in all applications and need to be verified in a specific application.

### A.2.3.2 RED Signal

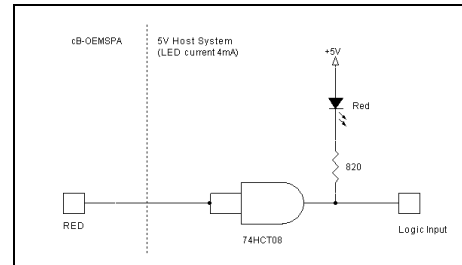
The RED logic LED signal is not multiplexed with any other functionality, which makes the design more straightforward. See Figure 21 for a 3.3V design.

In a 5V system the high state output (2.8V) from the module is not enough to turn off the LED so a 74HCT08 buffer can be used to raise the high level to 5V (see Figure 22).

The 74HCT08 gate is available in a single gate package (74AHCT1G08).



**Figure 21: A red LED in a 3.3V host system. The status of the signal can also be used as input to a host controller.**



**Figure 22: A red LED in a 5V host system. The status of the signal can also be used as input to a host controller.**

The RED signal pin is also used to select Logic Level mode (instead of RS232) for connectBlue product with internal RS232 driver. The mode functionality is not applicable on cB-0901 because there is no internal RS232 driver available. To be compatible with these products check the data-sheet about this signal.

The Red signal is not allowed to be pull-down when using the SerialSelect signals for RS485/RS422 (see A.2.2.4).

### A.2.3.3 GREEN/Switch-1 signal

The GREEN/Switch-1 signal is a multiplexed signal:

- **GREEN** - Logic green LED signal (see Chapter 3, Table 14). Becomes valid 500ms after start up.
- **Switch-1** - The module reads the status of the signal at startup to decide if the serial interface settings shall be restored (LOW) (see the Serial Port Adapter AT Commands specification I for more details). The input signal must be stable for the first 500ms after startup (after reset/power on reset). The module will restore all factory settings if both the Switch-1 and Switch-0 signals are low during start up.

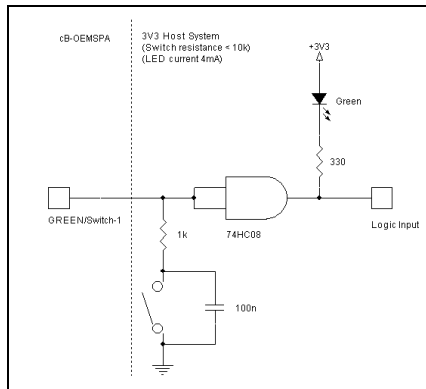
The signal is internally pulled-up ( $16k\Omega$ ) to 3.0V for NOT restoring settings to default.

**Note! The internal  $16k\Omega$  pull-up is smaller than on previous product generations from connectBlue. This requires a smaller pull-down resistor ( $1k\Omega$ ) for a low state.**

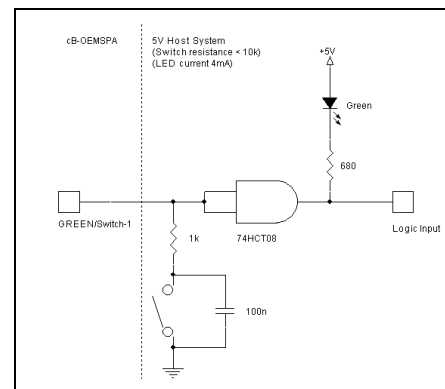
If a LED is used and a switch is required to be able to restore the settings, a high impedance buffer need to prevent the signal from being pulled-up via the LED. A 74HC08 logic gate can be used in a 3/3.3V system (see Figure 23) and a 74HCT08 logic gate in a 5V system (see Figure 24).

Both gates are available in a single gate package (74AHC1G08/74AHCT1G08).

Sometimes, over time, switch contacts can get an oxide layer. This may cause the closed switch resistance to become too high to sink the signal to logic LOW (the signal is internally pulled-up to  $16k\Omega$ ). A design that prevents this can be found in Figure 28.



**Figure 23: Switch-1 used together with a green LED in a 3.3V host system. The status of the signal can also be used as input to a host controller. Notice the  $1k\Omega$  serial resistor.**

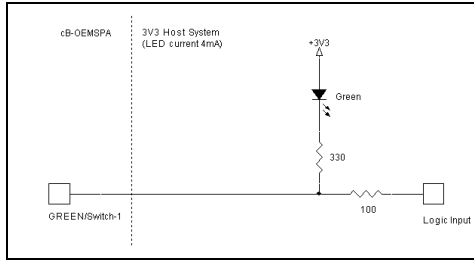


**Figure 24: Switch-1 used together with a green LED in a 5V host system. The status of the signal can also be used as input to a host controller. Notice the  $1k\Omega$  serial resistor.**

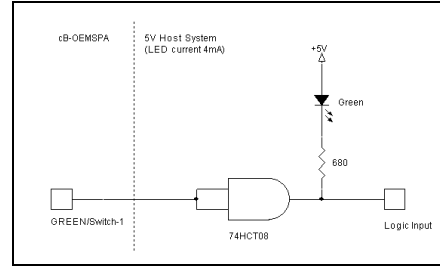
The buffer can be removed in a 3.3V system if no restore switch is required (see Figure 25).

In a 5V system the high state output (2.8V) from the module is not enough to turn off the LED, so a 74HCT08 buffer can be used to raise the high level to 5V (see Figure 26).

The 74HCT08 gate is also available in a single gate package (74AHCT1G08).



**Figure 25: No restore switch used but a green LED in a 3.3V host system. The status of the signal can also be used as input to a host controller.**

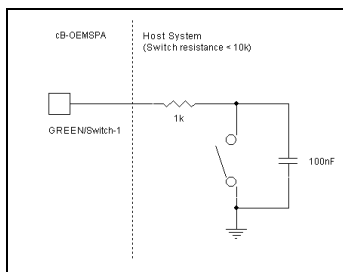


**Figure 26: No restore switch used but a green LED in a 5V host system. The status of the signal can also be used as input to a host controller.**

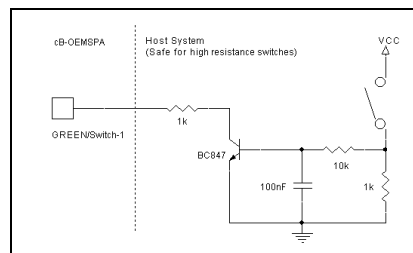
A serial resistor to the restore switch must be used to prevent a short circuit when the GREEN/Switch-1 pin is in output HIGH state and the switch is pressed (see Figure 27).

Sometimes, over time, switch contacts can get an oxide layer. This may cause the closed switch resistance to become too high to sink the signal to logic LOW (the signal is internally pulled-up to 16kΩ). A design that prevents this can be found in Figure 28.

The GREEN/Switch-1 pin can be left unconnected if none of its functionality is required.



**Figure 27: A low resistance restore switch used. Notice the 1kΩ serial resistor.**



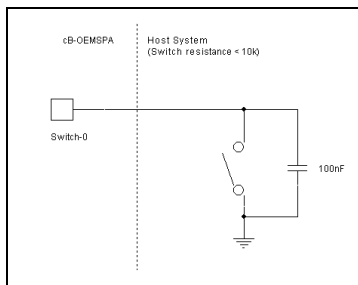
**Figure 28: If the resistance in the switch is not guaranteed to be low enough, a safer design can be used. Notice the 1kΩ serial resistor.**

### A.2.3.4 Switch-0 Signal

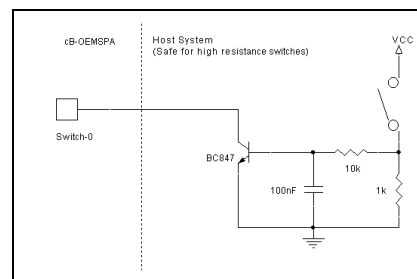
Switch-0 is not multiplexed with other functionality and a switch is easily implemented (see Figure 29).

Sometimes, over time, switch contacts can get an oxide layer. This may cause the closed switch resistance to become too high to sink the signal to logic LOW (the signal is internally pulled-up to 16kΩ). A design that prevents this can be found in Figure 30.

The Switch-0 pin can be left unconnected if its functionality is not used.



**Figure 29: A low resistance function switch used.**



**Figure 30: If the resistance in the switch is not guaranteed to be low enough, a safer design can be used.**



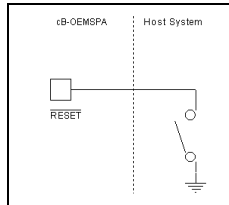
---

## A.2.4 Reset

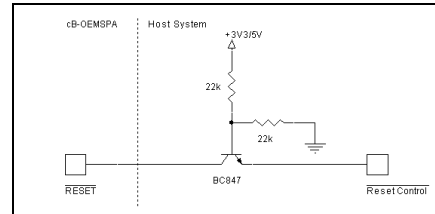
The RESET pin can be connected to an external reset source, see Figure 31 for a switch example.

If the reset signal is connected to an output signal it must be an open drain collector, see Figure 32. Notice the capacitive load on the RESET pin in Table 12, section 2.3.

The RESET pin can be left unconnected if not used.



**Figure 31: A reset switch.**



**Figure 32: Design of an open collector reset from an active high output.**

## A.2.5 A Complete 5V Host System Interface

This is a complete 5V host system interface example with an RGB LED and two switches (except the serial interface, see section A.2.2 for information). The design is based on the LM339 Quad OP-amp instead of logic gates.

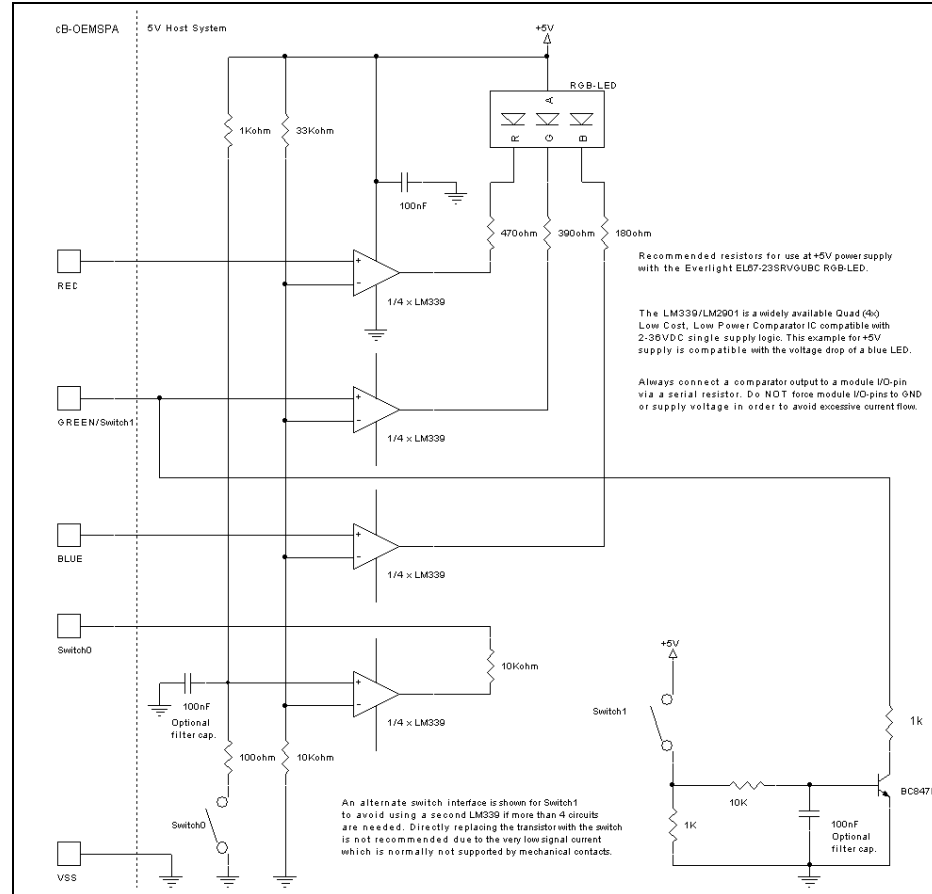


Figure 33: A complete 5V host interface with operational amplifier