



ALL RIGHTS RESERVED. NO PORTION OF THIS PUBLICATION, WHETHER IN WHOLE OR IN PART CAN BE REPRODUCED WITHOUT THE EXPRESS WRITTEN CONSENT OF SPC TECHNOLOGY.

SPC-F005.DWG

REVISIONS

DOC. NO. SPC-F005 • Effective: 7/8/02 • DCP No: 1398

| DCP # | REV | DESCRIPTION | DRAWN | DATE     | CHECKD | DATE     | APPRVD | DATE     |
|-------|-----|-------------|-------|----------|--------|----------|--------|----------|
| 1876  | A   | RELEASED    | EO    | 05/23/06 | TL     | 06/07/06 | HO     | 06/07/06 |



RoHS Compliant

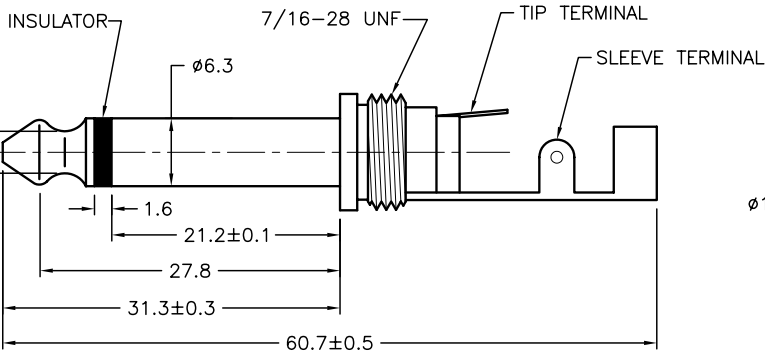

**BODY**

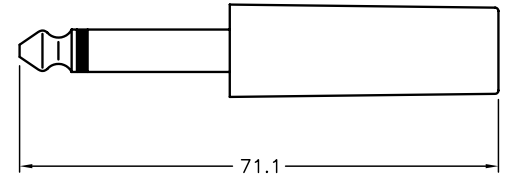
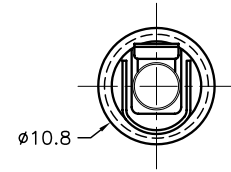

**ASSEMBLY**

**Specification:**

1. Metal: Bress, Nickel-Plated
2. Insulator: Delrin
3. Plastic Handle: ABS

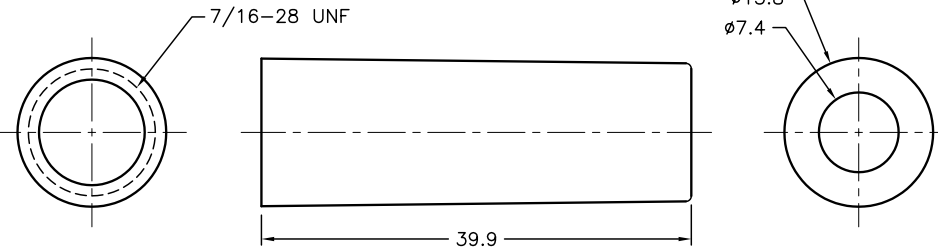

**PLASTIC HANDLE**

| SPC TYPE No. | COLOR |
|--------------|-------|
| SPC15225     | RED   |
| SPC15352     | BLACK |

DISCLAIMER:  
ALL STATEMENTS AND TECHNICAL INFORMATION CONTAINED HEREIN ARE BASED UPON INFORMATION AND/OR TESTS WE BELIEVE TO BE ACCURATE AND RELIABLE. SINCE CONDITIONS OF USE ARE BEYOND OUR CONTROL, THE USER SHALL DETERMINE THE SUITABILITY OF THE PRODUCT FOR THE INTENDED USE AND ASSUME ALL RISK AND LIABILITY WHATSOEVER IN CONNECTION THEREWITH.

TOLERANCES:  
Unless Otherwise Specified  
.X ±0.2 [0.008]  
.XX ±0.12 [0.005]

|              |          |
|--------------|----------|
| DRAWN BY:    | DATE:    |
| EKLAS ODISH  | 05/23/06 |
| CHECKED BY:  | DATE:    |
| THOMAS LEE   | 06/07/06 |
| APPROVED BY: | DATE:    |
| HISHAM ODISH | 06/07/06 |

|                                |          |                     |               |
|--------------------------------|----------|---------------------|---------------|
| DRAWING TITLE:                 |          |                     |               |
| 6.3mm TWO CONDUCTOR PHONE PLUG |          |                     |               |
| SIZE                           | DWG. NO. | ELECTRONIC FILE     | REV           |
| A                              | TA-755   | TA-755.DWG          | A             |
| SCALE:                         | NTS      | U.O.M.: mm [INCHES] | SHEET: 1 OF 1 |