

Features

- RoHS compliant*
- Power rating at 70 °C: CR2010 - 1/2 W, CR2512 - 1 W
- Tight tolerances of bottom electrode width
- Three layer termination process with nickel barrier prevents leaching and provides excellent solderability

- Suitable for most types of soldering processes
- Standard packaging on tape and reel

CR2010/CR2512 - Chip Resistors

Electrical Characteristics

Characteristic	Model CR2010	Model CR2512
Power Rating @ 70 °C	1/2 W	1 W
Operating Temperature Range	-55 °C to +155 °C	
Derated to 0 Load at	+155 °C	
Maximum Working Voltage	200 V	
Maximum Overload Voltage	400 V	
Resistance Range: 1 %, E-96 + E-24 5 %, E-24	10 ohms to 1 megohm 1 ohm to 10 megohms 0 ohm Jumper <50 milliohms	
Temperature Coefficient: 1 % Tolerance 5 % Tolerance 1 ohm to 10 ohms	±100 ppm/°C ±200 ppm/°C -200 ppm/°C to +500 ppm/°C	

Chip Dimensions

Dimension	Model CR2010	Model CR2512
L	5.00 ± 0.20 (0.197 ± 0.008)	6.30 ± 0.20 (0.248 ± 0.008)
W	2.50 ± 0.20 (0.098 ± 0.008)	3.10 ± 0.20 (0.122 ± 0.008)
H	0.60 ± 0.10 (0.024 ± 0.004)	0.60 ± 0.15 (0.024 ± 0.006)
l ₁	0.60 ± 0.25 (0.024 ± 0.010)	0.60 ± 0.25 (0.024 ± 0.010)
l ₂	0.60 ± 0.25 (0.024 ± 0.010)	0.60 ± 0.25 (0.024 ± 0.010)

Derating Curve

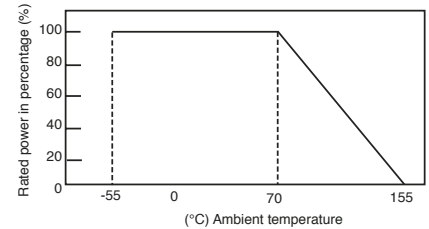

For Standard Values Used in Capacitors, Inductors, and Resistors, [click here](#).

Dimensional Drawing

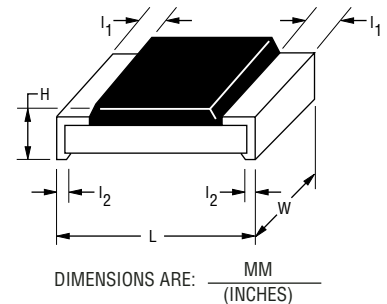

How To Order

Model _____
(CR = Chip Resistor)

Size _____
• 2010
• 2512

Resistance Tolerance _____
F = ±1 %Used with "X" TCR code only for values from 10 ohms through 1 megohm.
J = ±5 %Used with "W" TCR code for values from 10 ohms through 10 megohms. Used with "/" TCR code for zero ohm (jumper) and for values from 1 ohm through 9.1 ohms.

TCR (ppm/°C) _____
X = ±100Used with "F" Resistance Tolerance code only for values from 10 ohms through 1 megohm.
W = ±200Used with "J" Resistance Tolerance code only for values from 10 ohms through 10 megohm.
/ = -250 to +500Used with "J" Resistance Tolerance code only for zero ohm (jumper), and for values from 1 ohms through 9.1 ohms.

Resistance Value _____
For 1 % Tolerance:
<100 ohms....."R" represents decimal point (example: 24R3 = 24.3 ohms)
≥100 ohms.....First three digits are significant, fourth digit represents number of zeros to follow (example: 8252 = 82.5k Ω).
For 5 % Tolerance:
<10 ohms....."R" represents decimal point (example: 4R7 = 4.7 ohms)
≥10 ohms.....First two digits are significant, third digit represents number of zeros to follow (example: 474 = 470k ohms; 000 = Jumper).

Packaging _____
E = Embossed Plastic Tape (4,000 pcs.) on 7 " Plastic Reel

Termination _____
LF = Tin-plated (RoHS compliant)

CR 2010 - F X - 8252 E LF

*RoHS Directive 2002/95/EC Jan 27 2003 including Annex
Specifications are subject to change without notice
Customers should verify actual device performance in their specific applications..

CR2010/CR2512 - Chip Resistors

BOURNS®

Soldering Profile for RoHS Compliant Chip Resistors and Arrays



Marking Explanation

Resistors with 5 % tolerance may have a 3-digit or 4-digit resistance code. Complete information about resistance value and tolerance is found on the label of the reel of chip resistors.

- 5 %: 3 digits, first two digits are significant, third digit is number of zeros to follow. Letter R is decimal point for values from 1 to 9.9 ohms.
- 5 %: 4 digits, first three digits are significant, fourth digit is number of zeros to follow. Letter R is decimal point for values from 1 to 99.9 ohms.
- 1 %: 4 digits, first three digits are significant, fourth digit is number of zeros to follow. Letter R is decimal for values from 1 to 99.9 ohms.

Packaging Dimensions

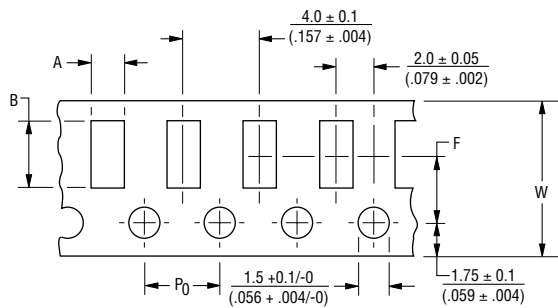

Dimension	Model CR2010	Model CR2512
A	$\frac{2.8 \pm 0.2}{(0.110 \pm 0.008)}$	$\frac{3.5 \pm 0.2}{(0.138 \pm 0.008)}$
B	$\frac{5.5 \pm 0.2}{(0.217 \pm 0.008)}$	$\frac{6.7 \pm 0.2}{(0.264 \pm 0.008)}$
W	$\frac{12.0 \pm 0.3}{(0.472 \pm 0.012)}$	$\frac{12.0 \pm 0.3}{(0.472 \pm 0.012)}$
F	$\frac{5.5 \pm 0.05}{(0.217 \pm 0.002)}$	$\frac{5.5 \pm 0.05}{(0.217 \pm 0.002)}$
P ₀	$\frac{4.0 \pm 0.1}{(0.157 \pm 0.004)}$	$\frac{4.0 \pm 0.1}{(0.157 \pm 0.004)}$

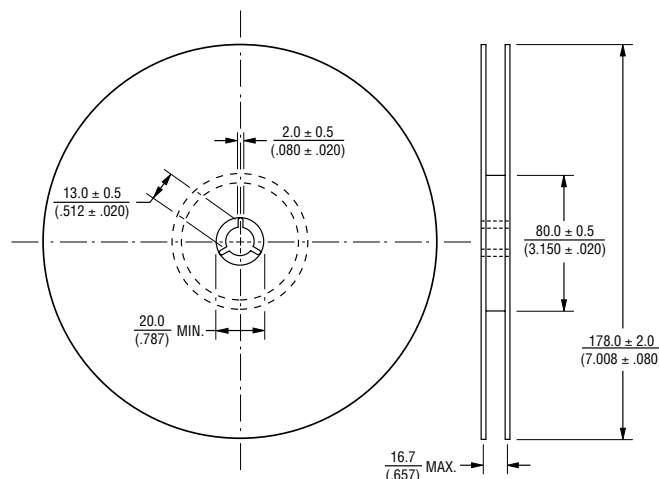

DIMENSIONS ARE: $\frac{\text{MM}}{\text{(INCHES)}}$

REV. 02/08

Specifications are subject to change without notice

Customers should verify actual device performance in their specific applications..