

VI TELEFILTER	Filter Specification	TFS 433P 1/5
----------------------	-----------------------------	---------------------

Measurement condition

Ambient temperature: 23 °C
 Input power level: 0 dBm
 Terminating impedances*: input: 190 Ω // -3,40 pF
 output: 190 Ω // -3,40 pF

Characteristics**Remark:**

Reference level for the relative attenuation a_{rel} of the TFS 433P is the minimum of the pass band attenuation a_{min} . The minimum of the pass band attenuation a_{min} is defined as the insertion loss a_e . The centre frequency f_c is the arithmetic mean value of the upper and lower frequencies at the 3 dB filter attenuation level relative to the insertion loss a_e . The nominal frequency f_N is fixed at 433,92 MHz without tolerance. The given values for the relative attenuation a_{rel} have to be reached at the frequencies given below even if the centre frequency f_c is shifted due to the temperature coefficient of frequency TC_f in the operating temperature range and due to a production tolerance for the centre frequency f_c .

D a t a	typ. value		Variation/ Limitation			
Insertion loss (Reference level)	$a_e = a_{min}$	2,60	dB	max	3,5	dB
Nominal frequency	f_N	-			433,92	MHz
Centre frequency	f_c	433,92	MHz			
2 dB bandwidth		700,0	kHz	min	400	kHz
3 dB bandwidth		800,0	kHz	min	440	kHz
6 dB bandwidth		955,0	kHz	min	560	kHz
Relative attenuation	a_{rel}					
$f_N \dots f_N \pm 200$ kHz		-		max	2,0	dB
$f_N \pm 200,0$ kHz ... $f_N \pm 220,0$ kHz		-		max	3,0	dB
$f_N \pm 220,0$ kHz ... $f_N \pm 280,0$ kHz		-		max	6,0	dB
$f_N - 1,0$ MHz ... $f_N - 5,92$ MHz 16,5	dB	min		15,0	dB	
$f_N - 5,92$ MHz ... $f_N - 19,92$ MHz	42,0	dB		min	40,0	dB
$f_N - 19,92$ MHz ... $f_N - 423,92$ MHz	55,0	dB		min	45,0	dB
$f_N + 1,0$ MHz ... $f_N + 8,0$ MHz	14,0	dB		min	10,0	dB
$f_N + 116,08$ MHz ... $f_N + 566,0$ MHz	60,0	dB		min	45,0	dB
Temperature coefficient of the frequency	TC_f^{**}	-0,040	ppm/K ²			
Frequency inversion temperature	T_0	10	°C			
Operating temperature range					- 25 °C ... + 80 °C	
Storage temperature range					- 45 °C ... + 120 °C	
Input power level				max	10,0	dBm

*) The terminating impedances depend on parasitics and q-values of matching elements and the board used, and are to be understood as reference values only. Should there be additional questions do not hesitate to ask for an application note or contact our design team.

***) $\Delta f_c(\text{Hz}) = TC_f(\text{ppm/K}^2) \times (T_0 - T_A)^2 \times f_{CAT}(\text{MHz})$

Generated :

Checked / approved :

TELEFILTER GmbH
 Potsdamer Straße 18
 D 14 513 TELTOW / Germany
 Tel: (+49) 3328 4784-0 / Fax: (+49) 3328 4784-30
 E-Mail: tft@telefilter.com

VI TELEFILTER reserves the right to make changes to the product(s) and/or information contained herein without notice. No liability is assumed as a result of their use or application. No rights under any patent accompany the sale of any such product(s) or information

Construction, pin configuration and 50 Ω - matching network

(All dimensions in mm)

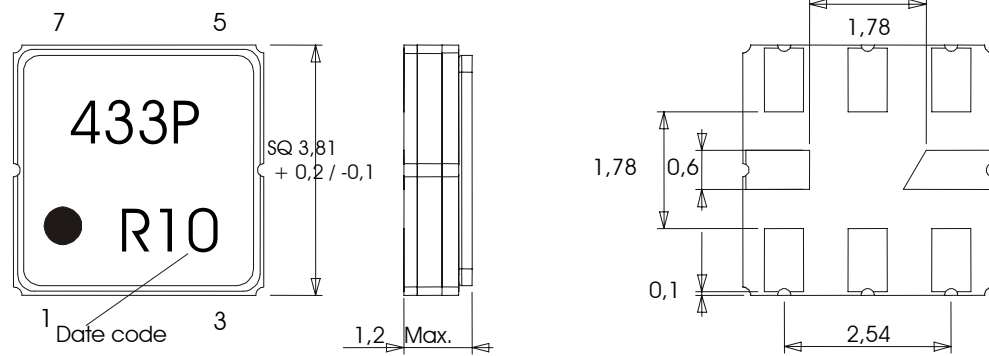

Pin 1	Ground	Pin 5	Output
Pin 2	Input	Pin 6	Ground
Pin 3	Ground	Pin 7	Ground
Pin 4	Package Ground	Pin 8	Package ground

Date code:	Year + week
N	2001
P	2002
R	2003
...	

50 Ohm Test circuit

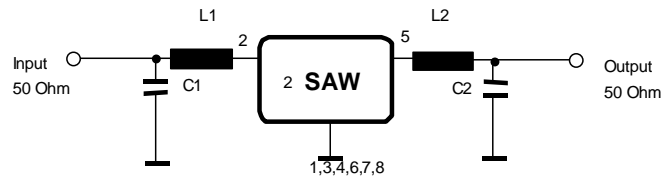

TELEFILTER GmbH
 Potsdamer Straße 18
 D 14 513 TELTOW / Germany
 Tel: (+49) 3328 4784-0 / Fax: (+49) 3328 4784-30
 E-Mail: tft@telefilter.com

VI TELEFILTER reserves the right to make changes to the product(s) and/or information contained herein without notice. No liability is assumed as a result of their use or application. No rights under any patent accompany the sale of any such product(s) or information

Stability Characteristics

After the following tests the filter shall meet the whole specification:

1. Shock: 500g, 18 ms, half sine wave, 3 shocks each plane;
DIN IEC 68 T2 - 27
2. Vibration: 10 Hz to 500 Hz, 0,35 mm or 5g respectively, 1 octave per min, 10 cycles per plan, 3 plans;
DIN IEC 68 T2 - 6
3. Change of temperature: -55 °C to 125°C / 30 min. each / 10 cycles
DIN IEC 68 part 2 – 14 Test N
4. Resistance to solder heat (reflow): reflow possible: twice max.;
for temperature conditions, please refer to the attached "Air reflow temperature conditions" on page 4;

Packing

Tape & Reel: IEC 286 - 3, with exception of value for N and minimum bending radius;
tape type II, embossed carrier tape with top cover tape on the upper side;

max. pieces of filters per reel:	3000
reel of empty components at start:	min 300 mm
reel of empty components at start including leader:	min 500 mm
trailer	min 300 mm

Tape (all dimensions in mm)

W : 12 ± 0,3
Po : 4 ± 0,1
Do : 1,5 + 0,1
E : 1,75 ± 0,1
F : 5,5 ± 0,05
G (min) : 0,75
P2 : 2 ± 0,05
P1 : 8 ± 0,1
D1(min) : 1,5
Ao : 4,3 ± 0,1
Bo : 4,3 ± 0,1
CT : 9,5 ± 0,1

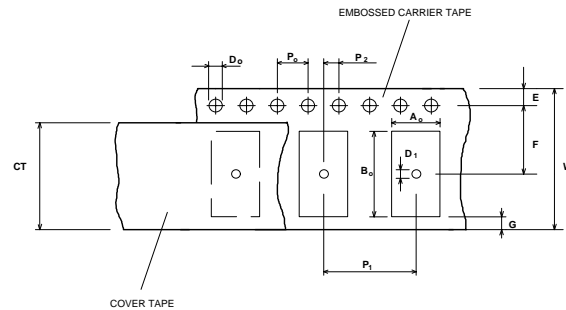

Reel (all dimensions in mm):

A : 330
W1 : 12,4 + 2,0
W2 (max) : 18,4
N (min) : 50
C : 13 +0,5/-0,2

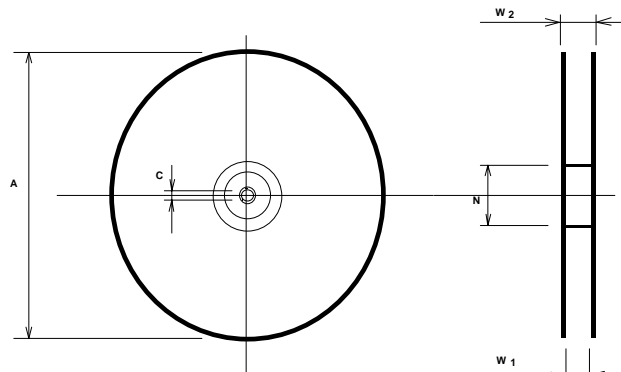

The minimum bending radius is 45 mm. The mounting surface of the filters faces the bottom side of the embossed carrier tape. Markings on the filters can be read if the upper side of the carrier tape is regarded with the sprocket holes on its right.

TELEFILTER GmbH
Potsdamer Straße 18
D 14 513 TELTOW / Germany
Tel: (+49) 3328 4784-0 / Fax: (+49) 3328 4784-30
E-Mail: tft@telefilter.com

VI TELEFILTER reserves the right to make changes to the product(s) and/or information contained herein without notice. No liability is assumed as a result of their use or application. No rights under any patent accompany the sale of any such product(s) or information

Air reflow temperature conditions

1st and 2nd air reflow profile

Name:	pre-heating periods	main-heating periods	peak temperature
Temperature:	150 °C - 170 °C	over 200 °C	255 °C ± 5 °C
Time:	60 sec. - 90 sec.	20 sec. - 25 sec.	

Chip-mount air reflow profile

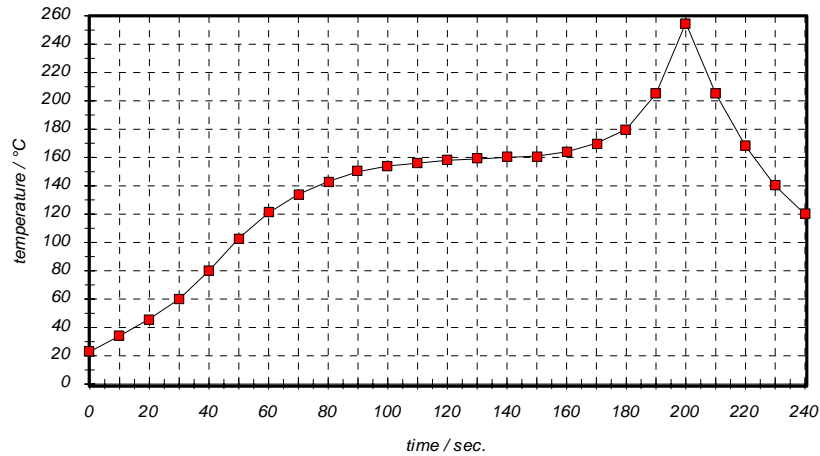

Table for temperature vs. time during the air reflow process

Tolerance of temperatures: ± 5 °C

time / sec.	temperature / °C	time / sec.	temperature / °C
0	23	140	160
10	34	150	161
20	46	160	164
30	60	170	170
40	80	180	180
50	103	190	205
60	121	195	230
70	134	200	255
80	143	205	230
90	150	210	205
100	154	215	180
110	156	220	165
120	158	230	140
130	159	240	120

TELEFILTER GmbH
 Potsdamer Straße 18
 D 14 513 TELTOW / Germany
 Tel: (+49) 3328 4784-0 / Fax: (+49) 3328 4784-30
 E-Mail: tft@telefilter.com

VI TELEFILTER reserves the right to make changes to the product(s) and/or information contained herein without notice. No liability is assumed as a result of their use or application. No rights under any patent accompany the sale of any such product(s) or information

History

Version	Reason of Changes	Name	Date
1.0	- Generation of development specification according to customer specification	Dr. Sabah	11.12.2001
1.1	- Filter specification, add of typical values, terminating impedance and change of package high	Dr. Sabah	05.03.2003

TELEFILTER GmbH
Potsdamer Straße 18
D 14 513 TELTOW / Germany
Tel: (+49) 3328 4784-0 / Fax: (+49) 3328 4784-30
E-Mail: tft@telefilter.com

VI TELEFILTER reserves the right to make changes to the product(s) and/or information contained herein without notice. No liability is assumed as a result of their use or application. No rights under any patent accompany the sale of any such product(s) or information