

Preliminary



SF2030A

243.95 MHz SAW Filter

- **Designed for PHS BTS IF Applications**
- **Excellent Size-to Performance Ratio**
- **Hermetic 11.5 X 4.0 mm Surface-Mount Case**
- **Complies with Directive 2002/95/EC (RoHS)**



Maximum Ratings

Rating	Value	Units
Operating Temperature Range	-15 to +80	°C
Storage Temperature Range	-40 to +85	°C
Maximum DC Voltage	30	V
Maximum Source Power	+15	dBm
Maximum Soldering Profile	260°C for 30sec	

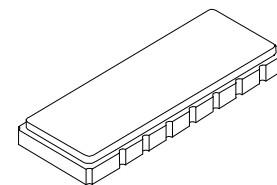

SM1154-14

Electrical Characteristics

Characteristic	Sym	Notes	Min	Typ	Max	Units
Nominal Frequency	f_N			243.95		MHz
Nominal Insertion Attenuation					5	dB
Pass band width at 3 dB (Relative to f_N)	B_{3dB}					kHz
Point of left side					-150	
Point of right side			+150			
Amplitude Ripple (peak-valley) FN - 110 kHz ---- FN + 110kHz				0.6	1.0	dB
Group Delay Ripple FN - 110 kHz ---- FN + 110kHz					0.5	µsec
Relative Attenuation (Relative to f_N)						
FN - 21.6 MHz			60			dB
FN - 21.4 MHz			60			dB
FN - 10.8 MHz			55			dB
FN - 1.2 MHz			30			dB
FN - 0.7 MHz			30			dB
FN - 0.6 MHz			30			dB
FN - 0.5 MHz			15			dB
FN + 0.5 MHz			15			dB
FN + 0.6 MHz			30			dB
FN + 0.7 MHz			30			dB
FN + 1.2 MHz			30			dB
FN + 10.8 MHz			55			dB
Lid Symbolization (YY=year, WW=week, S=shift) See note 4	RFM SF2030A YYWWS					

Notes:

1. Unless noted otherwise, all specifications apply over the operating temperature range with filter soldered to the specified demonstration board with impedance matching to 50 Ω and measured with 50 Ω network analyzer.
2. Unless noted otherwise, all frequency specifications are referenced to the nominal center frequency, f_c .
3. Rejection is measured as attenuation below the minimum IL point in the passband. Rejection in final user application is dependent on PCB layout and external impedance matching design. See Application Note No. 42 for details.
4. "LRIP" or "L" after the part number indicates "low rate initial production" and "ENG" or "E" indicates "engineering prototypes."
5. The design, manufacturing process, and specifications of this filter are subject to change.
6. Either Port 1 or Port 2 may be used for either input or output in the design. However, impedances and impedance matching may vary between Port 1 and Port 2, so that the filter must always be installed in one direction per the circuit design.
7. US and international patents may apply.
8. RFM, stylized RFM logo, and RF Monolithics, Inc. are registered trademarks of RF Monolithics, Inc.
9. ©Copyright 1999, RF Monolithics Inc.
10. Electrostatic Sensitive Device. Observe precautions for handling.

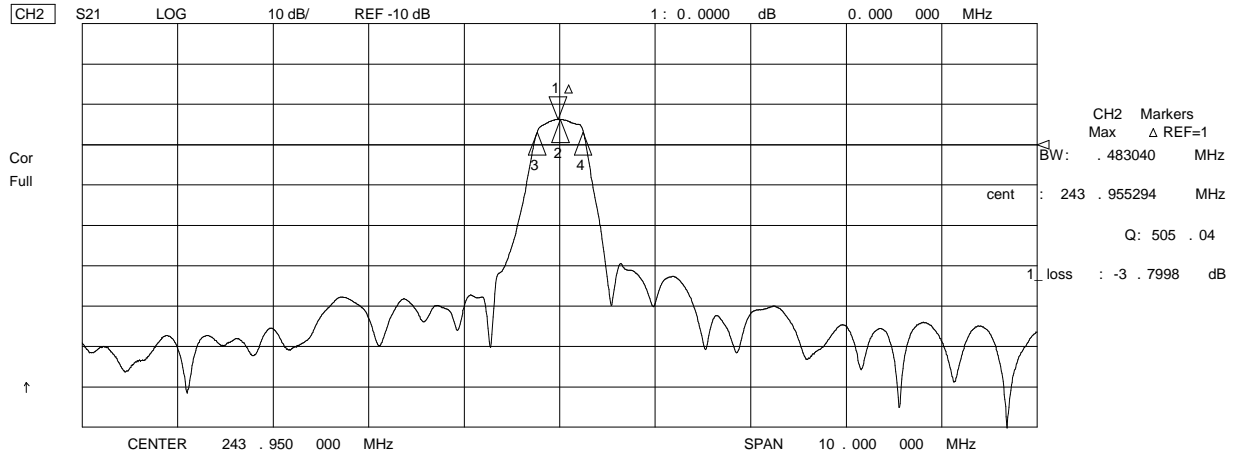
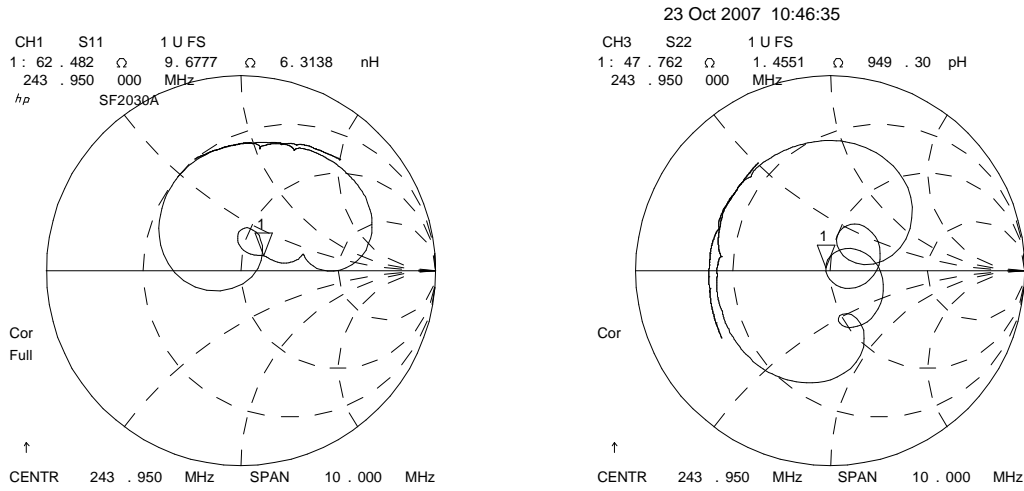
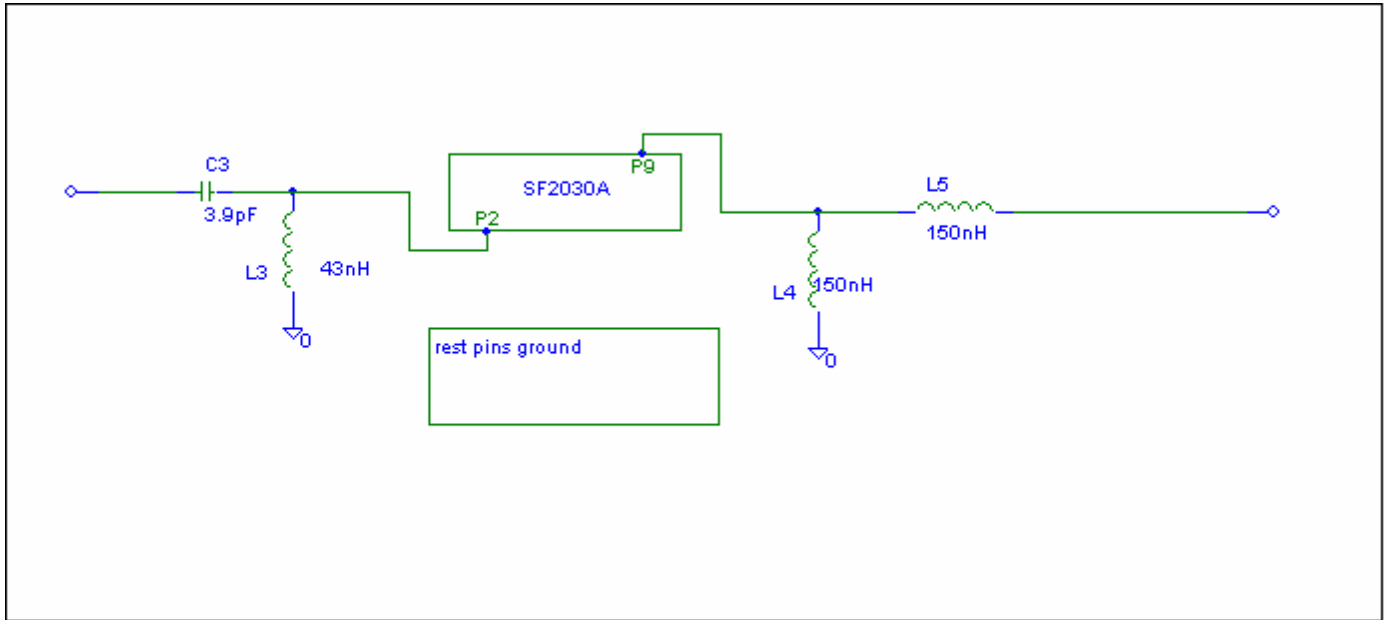

SF2030A Demo schematic

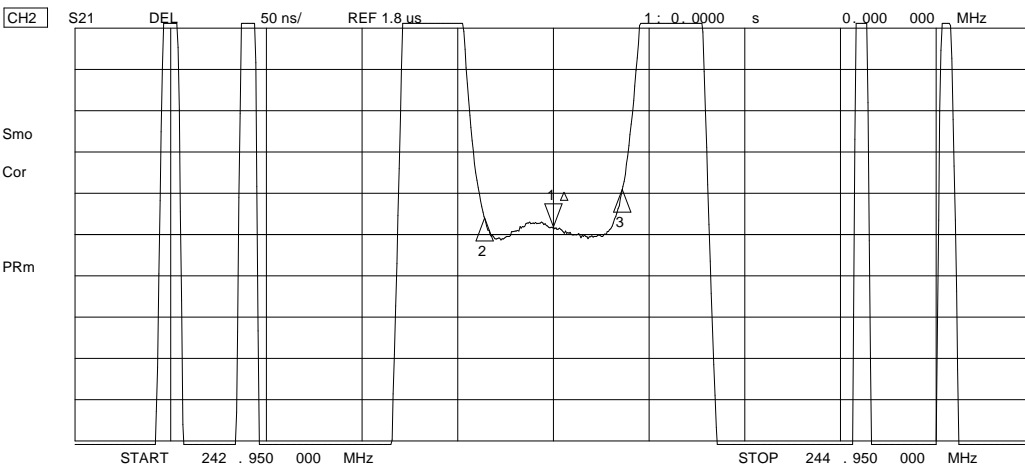
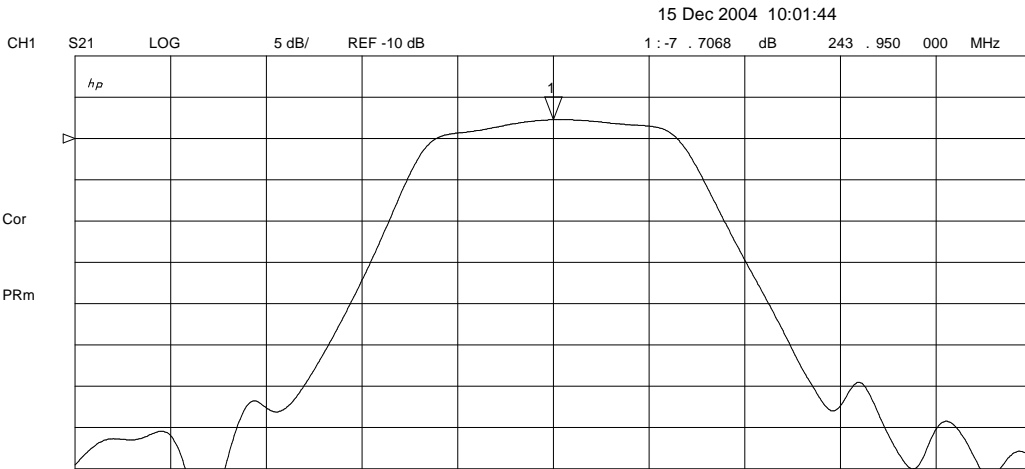
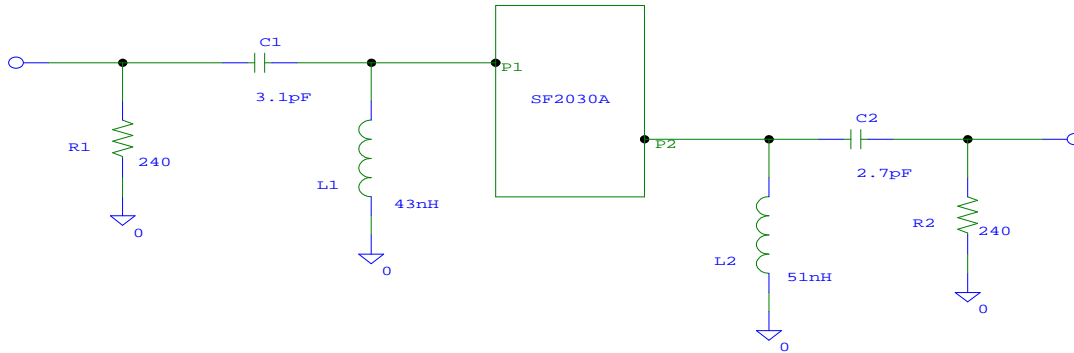

15 Dec 2004 10:04:38

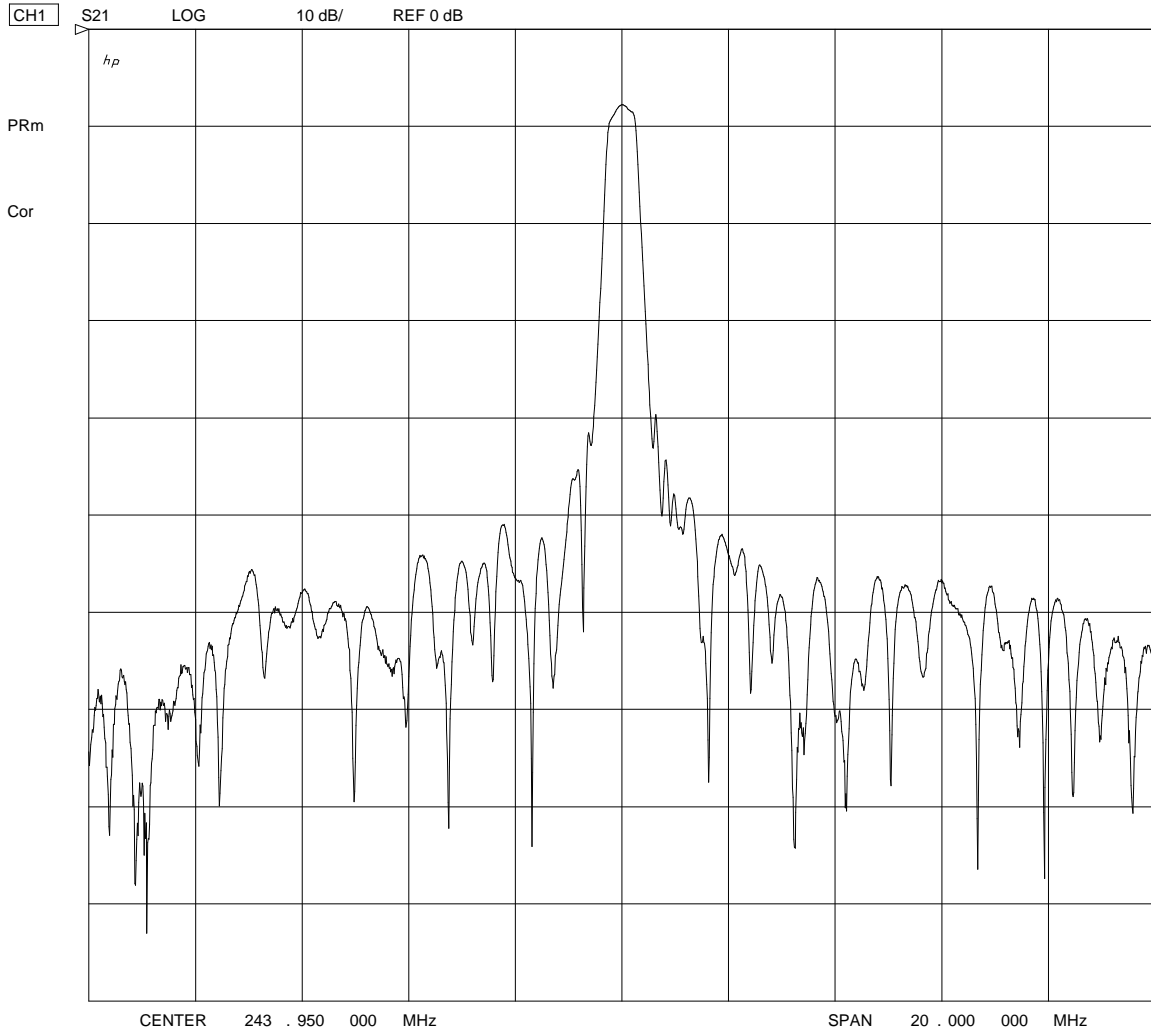

SM1154-14 Case

14-Terminal Ceramic Surface-Mount Case
11.5 x 4.0 mm Nominal Footprint

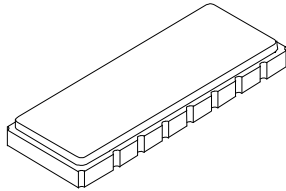

Dimension	Case Dimensions					
	mm			Inches		
	Min	Nom	Max	Min	Nom	Max
A	11.4	11.5	11.6	.442	0.450	0.458
B	3.8	4.0	4.2	.150	0.157	.166
C	1.4	1.6	1.8	.057	0.063	.069
D	1.3	1.5	1.7	.053	0.059	.065
E		0.76			0.030	
F		1.27			0.050	
G		1.27			0.050	
H		0.1			0.004	

Materials	
Solder Pad Termination	Au plating 30 - 60 μinches (76.2-152 μm) over 80-200 μinches (203-508 μm) Ni.
Lid	Fe-Ni-Co Alloy Electroless Nickel Plate (8-11% Phosphorus) 100-200 μinches Thick
Body	Al ₂ O ₃ Ceramic
Pb Free	

Electrical Connections	
Connection	Terminals
Input	2
Output	9
Ground	All Others

Recommended PCB Footprint

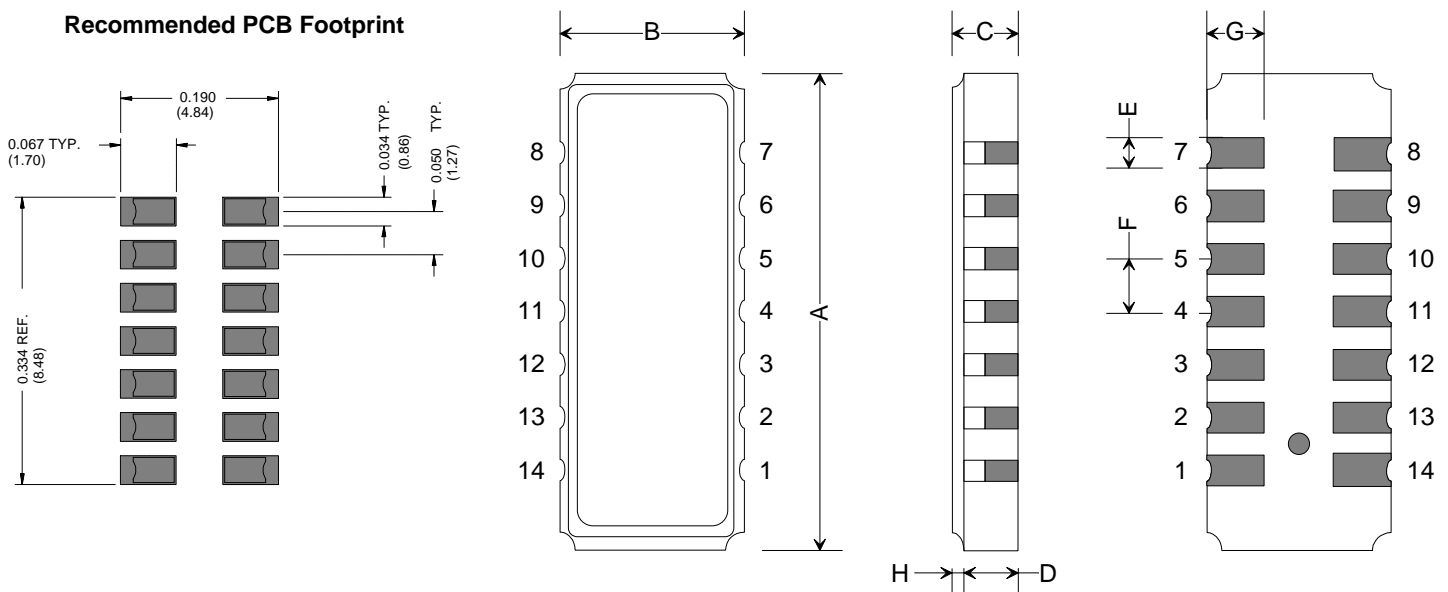

COMPONENT ORIENTATION and DIMENSIONS

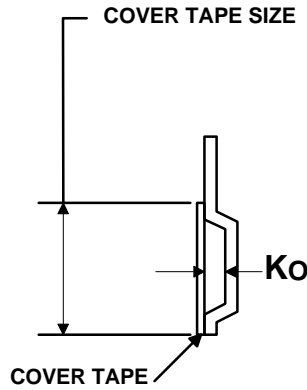
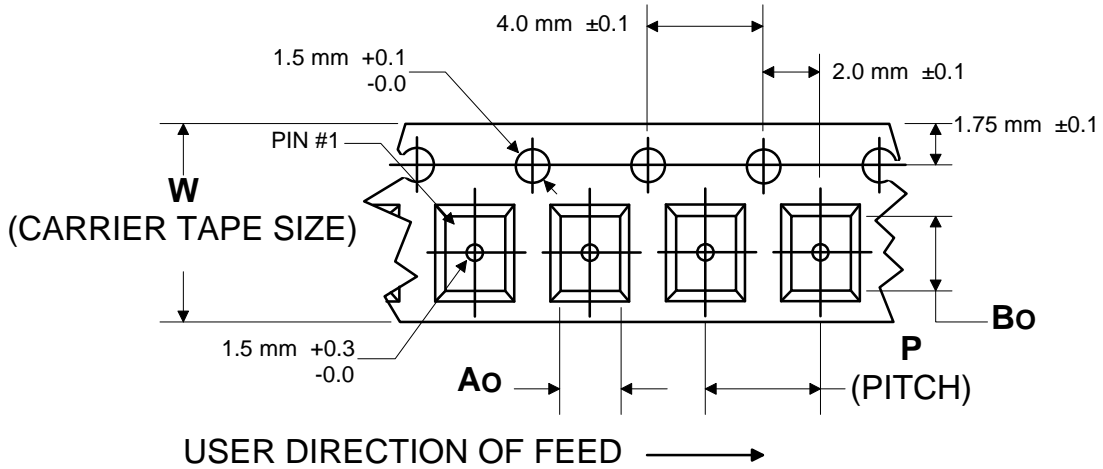

Carrier Tape Dimensions		
Ao	4.55 mm	±0.1
Bo	12.04 mm	±0.1
Ko	2.13 mm	±0.1
Pitch	8.00 mm	±0.1
W	24.00 mm	±0.3

Leader and Trailer specifications (Based upon EIA-481)

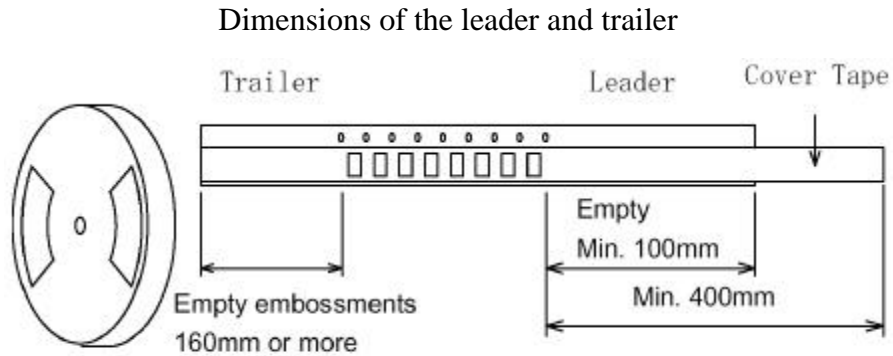

7 Inch Reel Quantity 500														
Symbol	A		N		C		D		B		W ₁		W ₂	
Dimension	178	+0 -4	60	±1	13	+0.5 -0.2	20.2	+1.5 -0	2	±0.5	24.4	+2 -0	30.4	MAX

13 Inch Reel Quantity 2000														
Symbol	A		N		C		D		B		W ₁		W ₂	
Dimension	330	+0 -4	100	±2	13	+0.5 -0.2	20.2	+1.5 -0	2	±0.5	24.4	+2 -0	30.4	MAX

Dimensional drawing of the reel

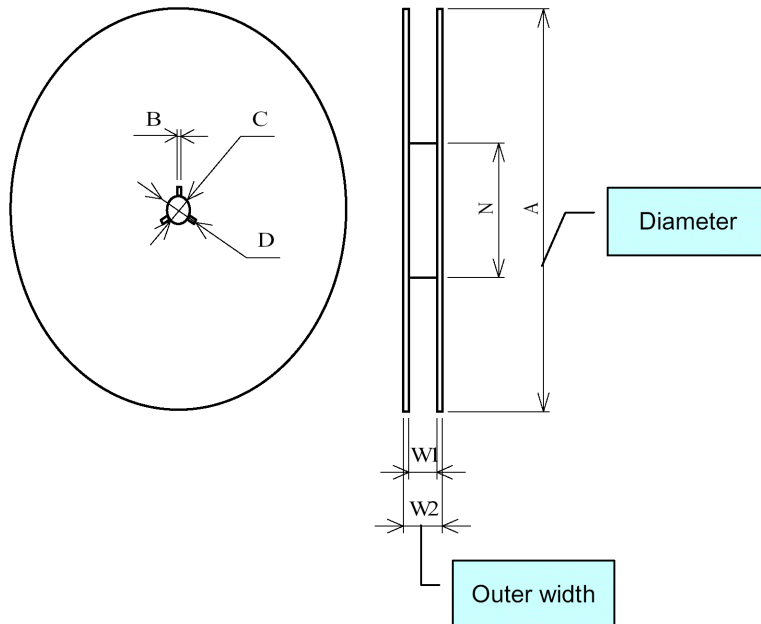

Additional items**(1) Cover tape peeling strength**

The cover tape shall be adhered evenly to the carrier tape along both sides in the pulling direction.

The cover tape peeling strength shall be as follows for an angle between the cover tape and the pulling direction of 165° to 180° (see the figure) and a peeling speed of 300mm/min. ±10mm/min.

[EIA-481] 0.1N to 1.3N for a tape width of 12 to 56mm

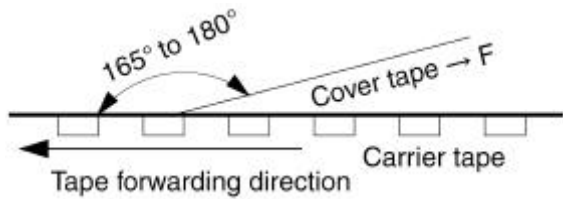
**Fixing method**

1. Insert the tip of the carrier tape into the groove.
2. Fix the tip of the cover tape with adhesive tape.

Tape material

(1) Carrier tape [anti-charging treatment: carbon used] Surface resistivity: 1×10^8 or less
Material: Polystyrene or Polycarbonate

(2) Cover tape material: Polyester (anti-charging treated) Surface resistivity: 1×10^{12} or less
 $t = 50$ to $100\mu\text{m}$

Warranty periods

Cover tape peeling strength and mounting performance of stored components.

2-1. Cover tape peeling strength: One year after delivery (Peeling strength: 0.1N to 1.3N)

Number of missing components

There shall not be two or more consecutive missing components. Also, the maximum number of missing components shall be the larger of one piece or 0.1%.

Storage environment

Keep the product on which taping has been performed to a temperature below 40°C and a humidity within 80% RH. Do not subject in the direct sun.

Reel labels shall follow the format shown below. The long side of the label must measure between 2.75 and 4.0 inches (68 to 100 mm). The short side of the label must measure between 1.5 and 2 inches (38 to 80 mm). Bar codes must conform to AIAG standard B10.

Information that is on the label:

- Device Type: RFM part number
- Code: RFM designated part ID or part date code
- Reel ID: Manufacturing reel identification
- Reel Qty: Quantity of parts on the reel
- Work Order: Manufacturing work order number
- Date: Date product was loaded on tape and reel.
- Company Identification: R. F. Monolithics, Inc.
- *Q. C.: Area for QA stamps, other information is required
- Country of assembly



Examples of acceptable reel labels

Location of label on reel is shown below. Reel labels must be placed entirely on plastic, without covering open sections of the reel. Design of reel must satisfy this requirement. Pin #1 must be located on the side opposite the reel label.

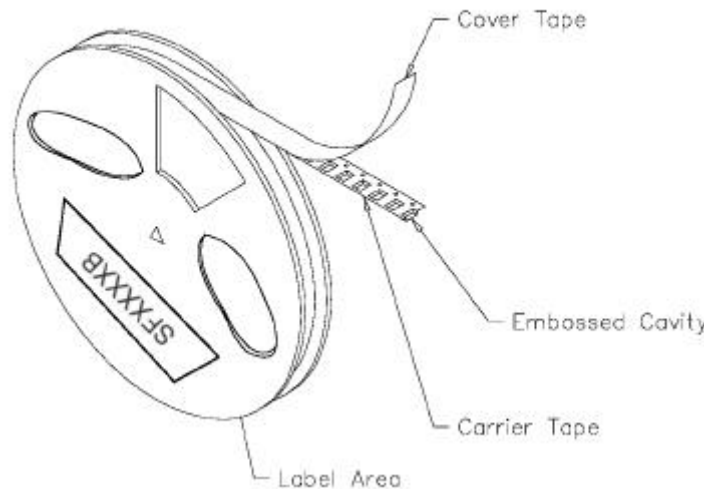

Package for Shipment

	Quantity Per Reel	Number Reels Per Carton	External Carton Dimensions	Reel Weight	Shipping Carton Weight	Total Weight
7 Inch Reel	500	4	254 x 254 x 127 mm 10 x 10 x 5 inches	896 g	448 g	1344 g
	500	10	254 x 254 x 203 mm 10 x 10 x 8 inches	2240 g	448 g	2688 g
	Quantity Per Reel	Number Reels Per Carton	External Carton Dimensions	Reel Weight	Shipping Carton Weight	Total Weight
13 Inch Reel	2000	2	356 x 356 x 102 mm 14 x 14 x 4 inches	1288 g	448 g	1736 g
	2000	4	356 x 356 x 178 mm 14 x 14 x 7 inches	2576 g	448 g	3024 g
	2000	8	356 x 356 x 356 mm 14 x 14 x 14 inches	5152 g	448 g	5600 g

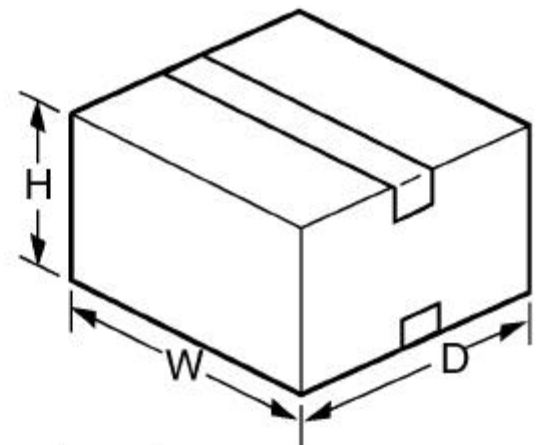
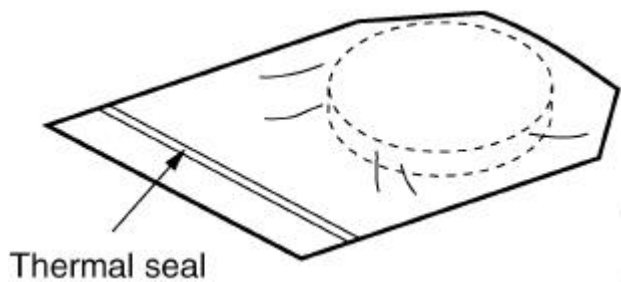
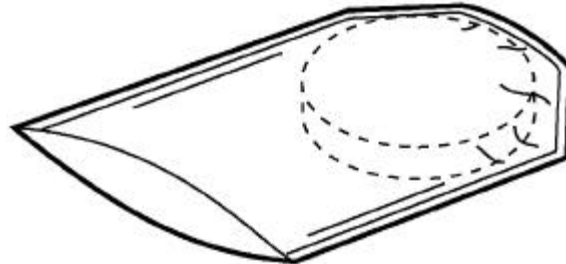

Shipment package

Sealing tape

RFM Qualification and Reliability Test				
Test		Standard	Test Parameters	Pass / Fail Criteria
1	Life at Elevated Temperature	MIL-STD-202 Method 108 Condition C	1,000 Hours 125°C Unbiased	Within Electrical & Hermetic Spec. (Note 1)
2	Temperature Cycling	JESD22 Method JA-104 Air-to-Air	-55 xCto +125 xC 20 min. Dwell 1,000 cycles	
3	Vibration, Variable Frequency	MIL-STD-883 Method 2007 Condition B	50g Max. 4 Cycles, 3 Axis 20 Hz to 2 kHz to 20 Hz	
4	Mechanical Shock	MIL-STD-883 Method 2002 Condition B	1,500g Max. 5 Shocks ±3 Axis	
5	Destructive Bond Strength	MIL-STD-883 Method 2011 Condition C	Wire Bond Pull Strength	2.0 grams (After Seal)
6	Die Shear Strength	MIL-STD-883 Method 2019	Shear Strength	0.6 kg (Strength/area limit in development)
7	Solderability (Note 2)	J-STD-002 Method B	8 hr. steam age 245 x C solder temperature 5 second dwell	>95% wetted surface
8	Physical Dimensions	JESD22 Method JB-100	Critical Dimensions	Within specifications
9	Temperature Characteristics	RFM Procedure	Frequency over Temperature	Within specifications
10	Terminal Strength (Note 2)	MIL-STD-833 Method 2004 Condition A & D	Cond. A-Lead Tension Cond. B -Pad Adhesionr 24	8 oz. - 30 sec. Visual Requirements & meets Hermetic Spec.
11	Resistance to Solvents	MIL-STD-883 Method 2015	Solvents a, b, d	Visual Requirements
12	Steady State Life	MIL-STD-883 Method 1005	1,000 Hours Max. Operating Temperature Rated Voltage	Within Electrical & Hermetic Spec. (Note 1)
13	Internal Water-Vapor Content	MIL-STD-883 Method 1018		< 5,001 PPM
14	Constant Acceleration	MIL-STD-883 Method 2001 Y1 Direction	30,000g	Within Electrical & Hermetic Spec. (Note 1)
15	Substrate Attach Strength	MIL-STD-883 Method 2027	Tensile Strength of Die Attachment	Custom per Device