

Low Range 3 Watt SMT Chip Resistor

LRF3W Series

- Tolerances to $\pm 1\%$
- 3 Watt @70°C power dissipation in a compact 1225 package
- Resistance range from 0.002 to 0.100 Ω
- Ideal for high current sensing applications
- Standard Sn/Pb and Pb-free (matte tin) terminations available

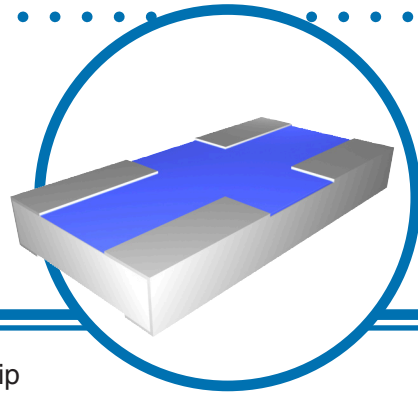

IRC's LRF3W series combines high power capabilities with small chip size and very low resistance to handle your current sensing needs.

The LRF3W utilizes IRC's proprietary thick film materials which possess superior thermal conductivity over other technologies. The result is significantly lower operating temperature and higher power dissipation.

Termination on the long sides minimizes TCE mismatch to PCBs.

Electrical Data

Resistance Range(Ω)	Absolute TCR (ppm/ $^{\circ}$ C)	Available Absolute Tolerances	Rated Power @ 70 $^{\circ}$ (W)	Voltage Rating (V)	Operating Temperature Range	Termination
0.002 - 0.004	± 550	$\pm 5\%$, $\pm 10\%$	3.0*	$\sqrt{P \times R}$	-55 $^{\circ}$ C to +150 $^{\circ}$ C	Sn/Pb solder or matte tin plated over nickel
0.005 - 0.100	± 100	$\pm 1\%$, $\pm 2\%$, $\pm 5\%$, $\pm 10\%$				

*Note: 3-Watt rating achieved with 500mm² Copper pad area around each termination pad. Maximum current is 25 amps.

Environmental Data

Environmental Test	Test Method	Performance (Resistance Change)
Thermal Shock	MIL-STD-202 Method 107 Condition F, -65 $^{\circ}$ C to +150 $^{\circ}$ C	$\pm 0.25\%$ (+0.001 Ω)
Short-time Overload	5 Seconds, 2 X Rated Power Maximum 25 Amps	$\pm 0.5\%$ (+0.0005 Ω)
High Temperature Exposure	MIL-PRF-55342 100 Hours, 150 $^{\circ}$ C, No Power	$\pm 0.5\%$ (+0.0005 Ω)
Load Life	1000 Hours, 70 $^{\circ}$ C, Rated Power	$\pm 1.0\%$ (+0.0005 Ω)
Moisture Resistance	MIL-STD-202 Method 106 No Bias	$\pm 0.5\%$ (+0.0005 Ω)
Low Temperature Operation	MIL-PRF-55342	$\pm 0.25\%$ (+0.0005 Ω)
Resistance To Solder Heat	MIL-STD-202 Method 210	$\pm 0.25\%$ (+0.001 Ω)
Leach Resistance	Molten Solder 250 $^{\circ}$ C	90 seconds minimum

General Note

IRC reserves the right to make changes in product specification without notice or liability. All information is subject to IRC's own data and is considered accurate at time of going to print.

Advanced Film Division • 4222 South Staples Street • Corpus Christi Texas 78411 USA
Telephone: 361 992 7900 • Facsimile: 361 992 3377 • Website: www.irctt.com



A subsidiary of
TT electronics plc

LRF3W Series Issue July 2008

Low Range 3 Watt SMT Chip Resistor



Temperature Rise Data

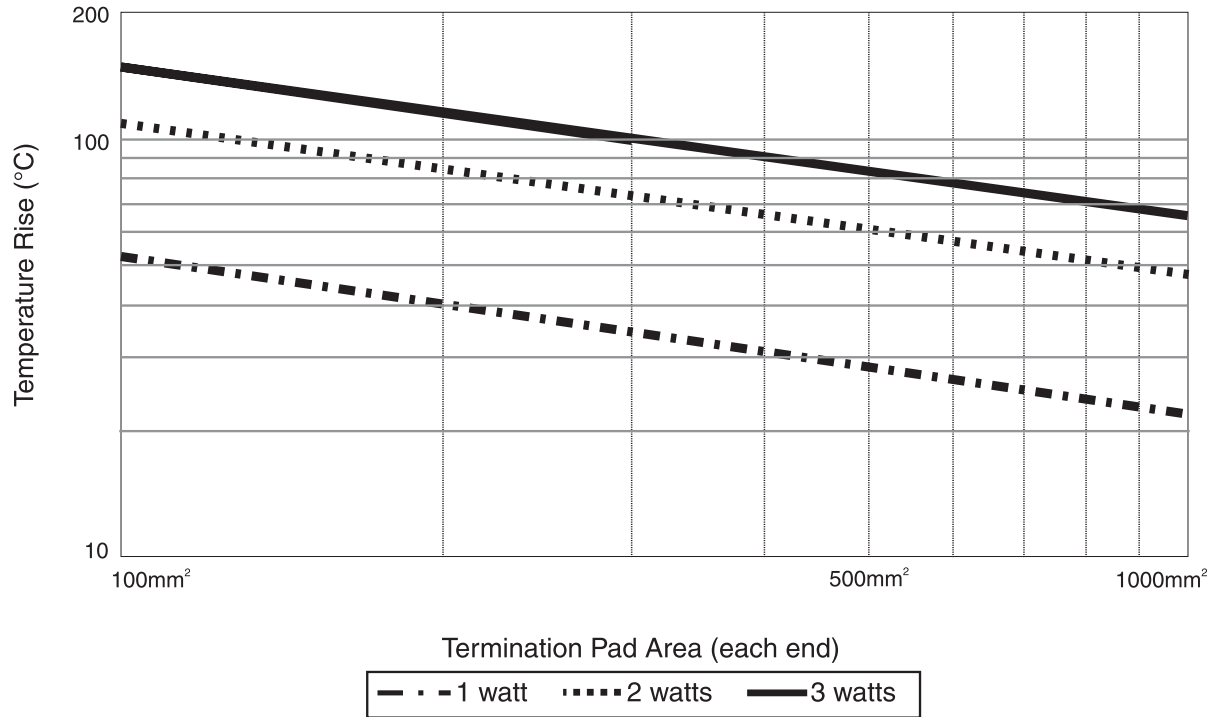

Pulse Power Data

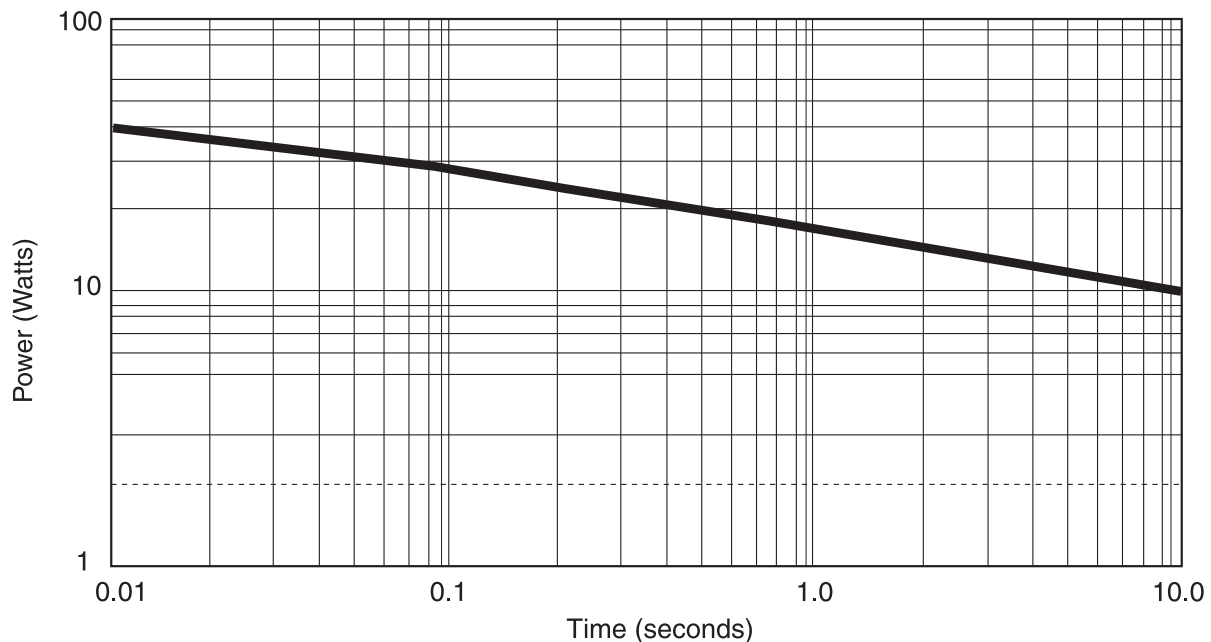

Low Range 3 Watt SMT Chip Resistor



Physical Data

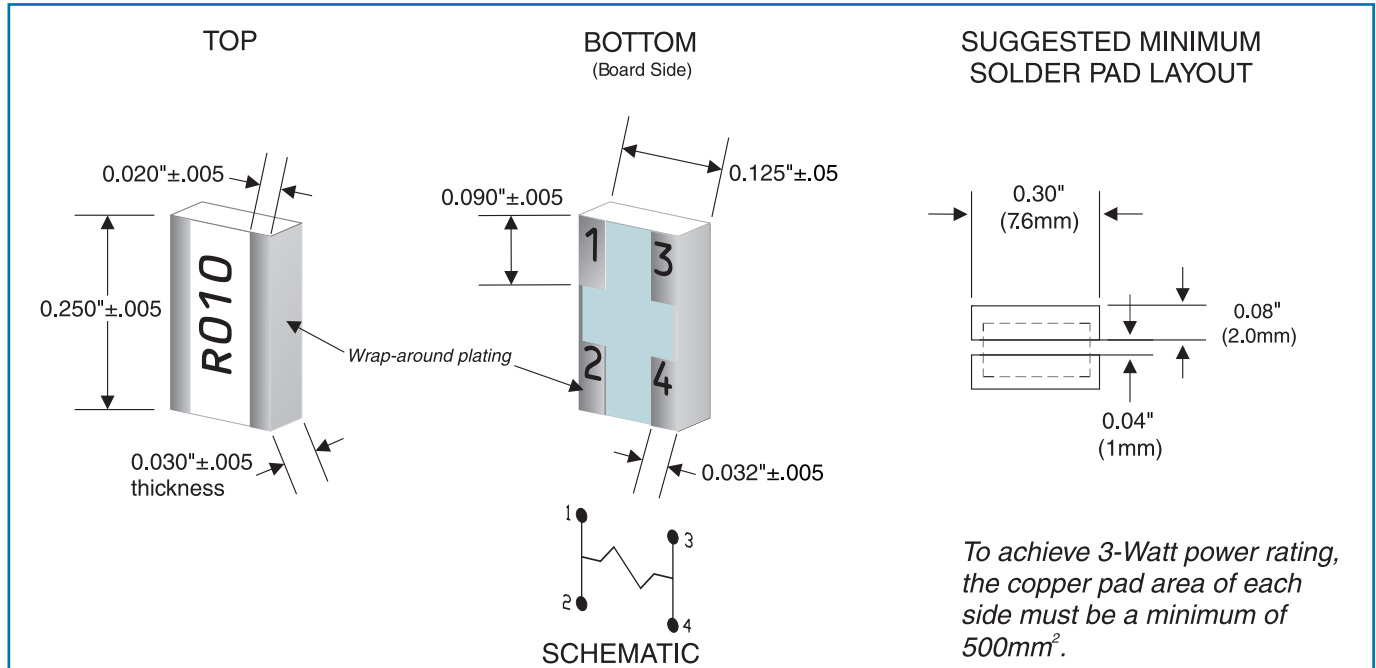

Power Derating Curve

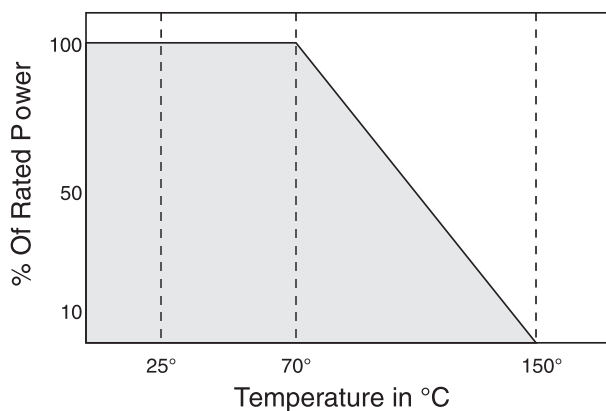

Ordering Data

Prefix LRC - LRF3WLF - 01 - R020 - F

Model
 LRF3W = 3 watt chip with standard Sn/Pb termination
 LRF3WLF = 3 watt chip with Pb-free (matte tin) termination

TCR Code

Resistance Code
 4-Digit resistance code
 Example: R050 = 0.050Ω; R005 = 0.005Ω

Tolerance Code
 K = ±10%; J = ±5%; G = ±2%; F = ±1%

For additional information or to discuss your specific requirements, please contact our Applications Team using the contact details below.