

Abstract

The ISL6745ALEVAL3Z is a low cost, high performance LED driver with power factor correction function, and is compatible with the widely used wall dimmers. It uses Intersil's voltage mode PWM controller ISL6745A to operate a SEPIC converter in discontinuous conduction mode (DCM). The design gives high flexibility on both the input side and output load. With the same circuit configuration, it works well with and without a triac dimmer. While connecting to any AC source from 50V to 140V without dimmer, it gives high power factor correction with high waveform factor of the input current. As it is powered through a phase controlled wall dimmer, the averaged rectified voltage varies as to the phase angle of the wall dimmer. The brightness of the LED is dimmed by changing the LED current, which is proportional to the averaged rectified voltage. This driver circuit can be used for various LED lighting applications. The number of LEDs in a string can be as many as 14, or as few as 4. Therefore, this design provides the luminaire manufacturers a high performance, low-cost solution for LED drivers compatible with the TRIAC phase-control dimmers.

Design Specifications

Configuration with Sinusoidal AC Source

- Input V_{AC} : 50V ~140V
- Typical Power Factor PF: 0.98
- Typical Efficiency η : 80%
- Output Current I_{LED} : 10mA ~ 670mA
- Output Voltage V_{OUT} : 10V ~ 46V
- Switching Frequency F_S : 100kHz
- Output Voltage Ripple V_{RPP} : 50mV_(P-P)

Configuration with Phase Controlled Triac Wall Dimmer

- Input V_{AC} : 80V~ 140V
- Efficiency η : 78%
- Output Current I_{LED} : 10mA ~ 670mA
- Output Voltage V_{OUT} : 10V ~ 46V
- Switching Frequency F_S : 100kHz
- Output Voltage Ripple V_{RPP} : 50mV_(P-P)

The System Block Diagram is shown in Figure 1, where the triac phase controlled dimmer chops the AC voltages, and the bridge rectifies it so the voltage applied to the SEPIC converter (L_1, L_2, C_2, Q_1, D) is rectified chopped AC voltage. The duty ratio of the SEPIC switch Q_1 is controlled by the voltage mode PWM controller ISL6745A. The modulation signal V_{ERR} is derived from the current control circuit integrating the difference between the measured current of the LED string ($K R_S I_{LED}$) and the reference current signal (V_X). The circuit is implemented with Intersil's high performance rail-to-rail op-amp EL5420. The reference signal (V_X) is derived from the rectified AC voltage over $C_1, |V_{AC}|$.

The top and bottom view of the evaluation board ISL6745ALEVAL3Z is shown in Figure 2. The detailed design procedure for a discontinuous conduction mode (DCM) SEPIC converter with power factor correction (PFC) is discussed in Application Note AN1411, available on Intersil's website.

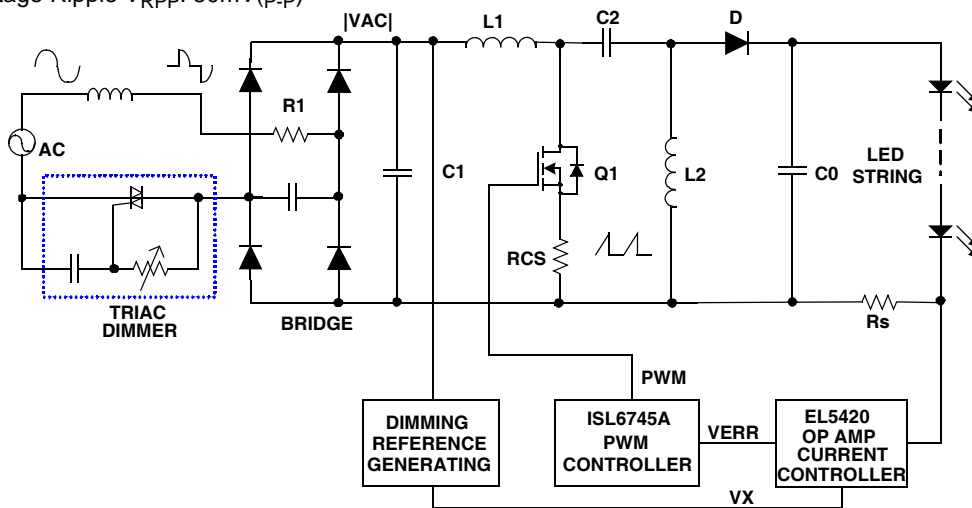

FIGURE 1. SYSTEM BLOCK DIAGRAM

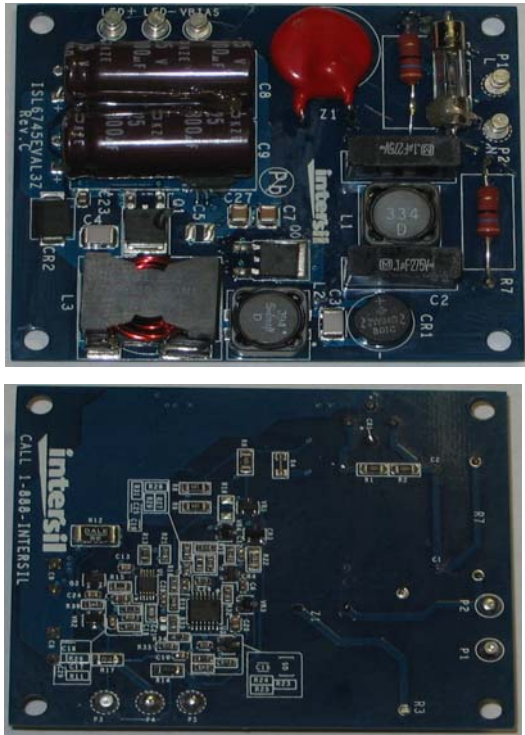

FIGURE 2. TOP AND BOTTOM VIEW OF LED DRIVER

Circuit Description

Unlike the active power factor correction converters, a voltage follower works in discontinuous conduction mode with comparatively constant duty ratio (D) within each utility cycle. There is no need for a PFC controller, or input voltage/current sense circuit. A simplified block diagram is shown in Figure 4. A typical waveform of the voltage after a triac dimmer is shown in Figure 3, where high dv/dt is noticed as the triac is turned on. A small capacitor C_1 is recommended here to filter out the switching noises. C_1 should be very small so that the voltage across it follows closely the rectified input voltage $|V_{AC}|$. An Electrolytic

capacitor is not suitable for this purpose, because of its high ESR and dielectric loss. Instead, a high frequency film capacitor such as metallized mylar or polypropylene should be used.

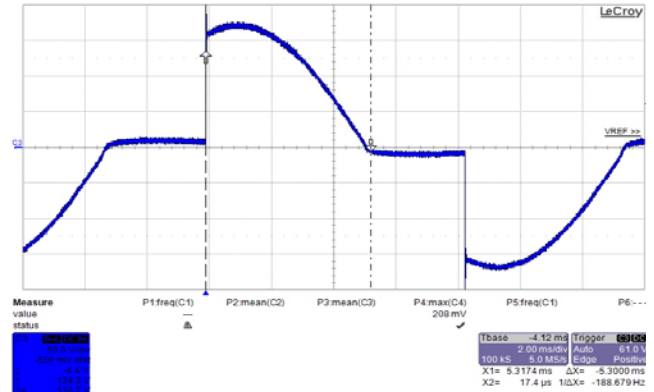

FIGURE 3. TYPICAL VOLTAGE AFTER THE TRIAC DIMMER

A damper resistor R_1 is needed to reduce the ringing effect because of the high dv/dt caused by the phase-angle dimming control of the triac. A minimum resistance should be used to ensure as low as possible power loss, while achieving normal dimming function. This resistor can be shorted if the driver is not triac dimmer controlled. L_1 and L_2 are selected so that the converter operates in DCM. The details of the design of the two inductors and capacitor C_2 can be found in Application Note AN1411.

One simple and low-cost solution for LED lamp brightness dimming is to control the LED current. It is assumed that the brightness of the LED lamp is linearly proportional to its current in normal conditions. Although the tune and color may change with operating current, the current based dimming method is acceptable for common LED luminaire applications. The current reference signal is in proportion to the averaged rectified voltage $|V_{AC}|$. The average voltage versus the phase angle α of triac dimmer is shown in Figure 5 for a commercial dimmer.

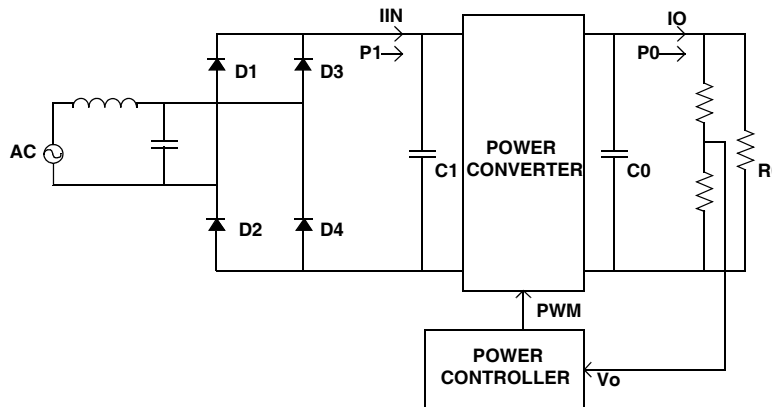

FIGURE 4. VOLTAGE FOLLOWER BLOCK DIAGRAM

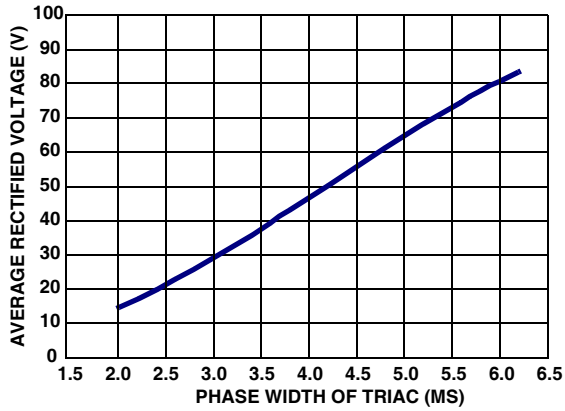

FIGURE 5. AVERAGE VOLTAGE vs ANGLE OF A TRIAC DIMMER

The schematic diagram of the current reference circuit is shown in Figure 6, where $|V_{AC}|$ is the rectified voltage after the rectifier. The high performance Op-Amp EL5420 clamps the current reference if the averaged input of U3A is beyond the bias voltage.

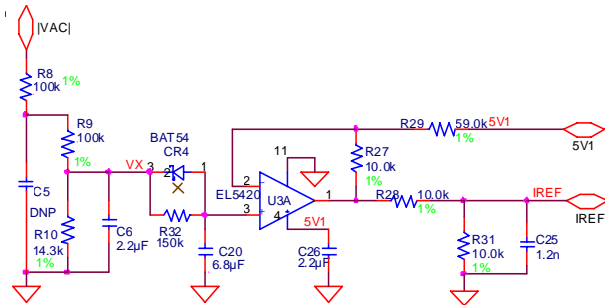

FIGURE 6. REFERENCE CIRCUIT

The LED current reference can be changed through R_{10} and R_{29} for applications with different rated operating current.

Figure 7 shows the LED current control circuit, where U4C provides 10 times of gain to reduce the power loss in the current sense resistor R_s . The integration circuit implemented with U3B eliminates any discrepancy between the reference (I_{REF}) and the LED current (I_{LED}). The time constant set by C_{19} and R_{33} should be large enough so that the second order harmonics will not appear in the control signal. A typical way is to set the time constant to 0.5 times of the utility frequency.

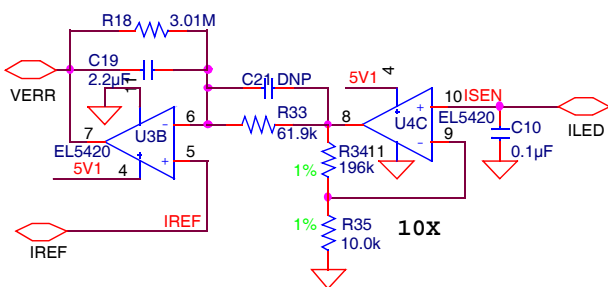

FIGURE 7. CURRENT CONTROL LOOP

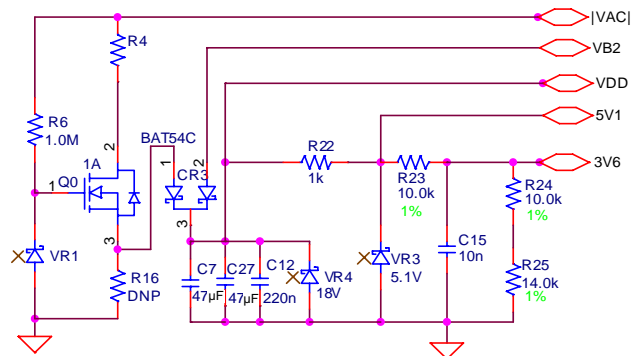

FIGURE 8. BIAS CIRCUIT

The bias circuit is shown in Figure 8 together with the reference voltages for the control circuit. At the beginning, the $|V_{AC}|$ increases so that the voltage at the gate of Q_0 is about 12V, Q_0 is turned on, and C_7 is charged up with $|V_{AC}|$ through R_4 . The ISL6745A starts to work as soon as the VDD is above its threshold. The output capacitor is charged up once the converter begins to work. The VB_2 presents an alternative bias choice for the driver for high voltage applications. If it is connected to the 3rd of the LED strings, 3 times of p-n junction voltage presents when LED strings start conducting current. This will shut off the current path of Q_0 , CR_3 , and prevents the Q_0 from conducting current in normal operation conditions.

The following circuit in Figure 9 shows a soft-start circuit with overvoltage protection and delayed start-up circuit. The VR_2 , R_{39} , R_{15} set up the over voltage protection of the output voltage applied to LED strings. For an overvoltage of any reasons, the Q_3 will be turned on, and the SS charges will be discharged through R_{15} . In order to suppress the LED over-shot current during start-up, a delayed start-up circuit consisting of U4D and Q_5 is necessary. Only after SS voltage is beyond 3.6V, the Q_5 will be turned off, and V_x is presented in the reference generation circuit. This greatly reduces the over-shot of the LED strings during start-up.

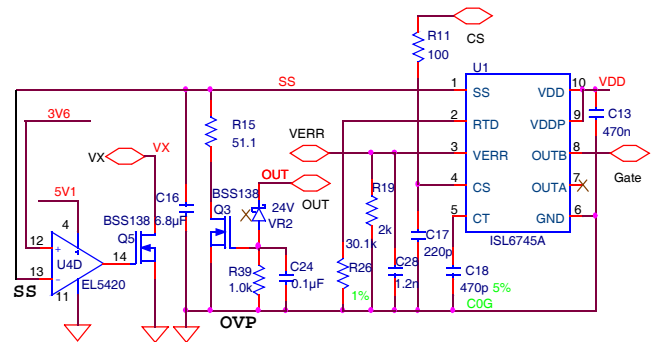

FIGURE 9. CONFIGURATION OF ISL6745A, SOFT-START UP AND OVERVOLTAGE PROTECTION

The overall schematics of the driver and the associated BOM are presented in the last pages of this application note. The fixture of the PCB is a 2-layer board with dimensions 3.15 by 2.65 inches. Figures 10 and 11 show the top view

and bottom view of the PCB layouts. Gerber files for the ISL6745ALEVAL3Z board are available upon request.

The performance of the LED driver board will be evaluated with and without dimmer respectively in the next sessions for various operation conditions.

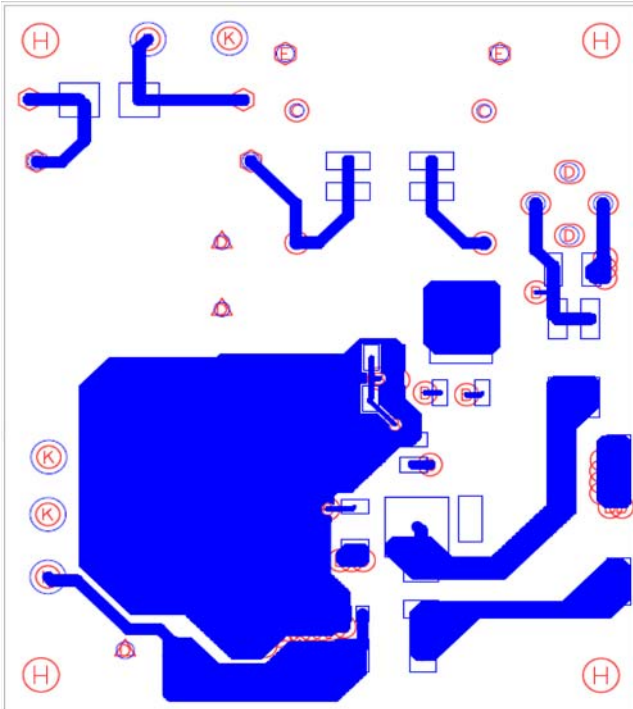

FIGURE 10. TOP VIEW OF THE PCB LAYOUT

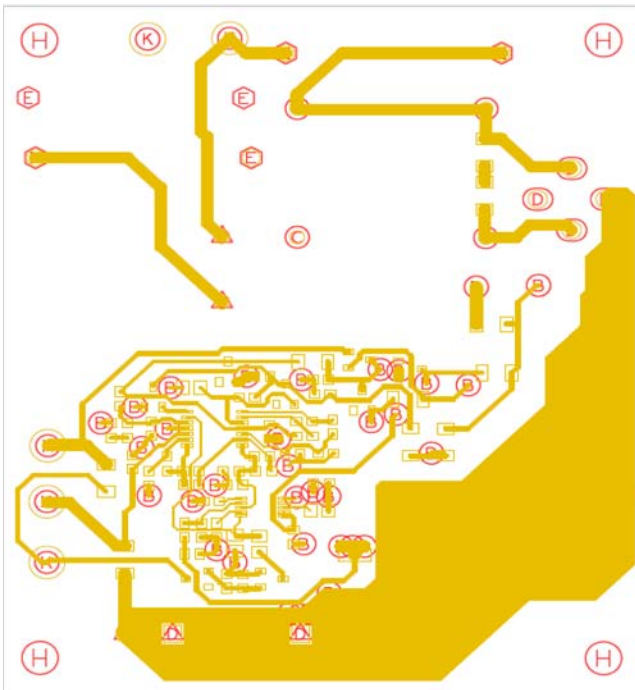

FIGURE 11. BOTTOM VIEW OF PCB LAYOUT

Performance Characteristics Without Dimmer

The schematics and BOM without dimmer are shown in the last pages of this document. Connect the P1 and P2 of the LED driver board to the AC power supply. A string of 6 Cree high power white LEDs are connected to the output terminal of the LED driver board. The efficiency of the driver is shown in Table 1. The operation waveforms are shown in Figures 12 to 18. Figures 12 to 15 show the rectified input voltage and current for different inputs. Channel 1 (yellow) shows the rectified input voltage (100V/DIV). Channel 4 (green) shows the input current (200mA/DIV). The input voltage and input current waveforms in Figure 16 shows the driver turning off within 2s. Figures 17 and 18 show the overshoot of the LED. Current is greatly reduced with the delayed start-up circuit.

TABLE 1. EFFICIENCY AND POWER FACTOR WITHOUT DIMMER

VAD (RMS) (V)	I INPUT (mA)	POWER IN (W)	I LED (mA)	V/LED (V)	PF	EFF (%)
140.25	126	15.43	0.673	18.584	0.8720	81.06
130.20	132	15.49	0.673	18.581	0.8972	80.73
120.12	140	15.52	0.672	18.587	0.9212	80.48
110.11	149	15.53	0.672	18.584	0.9427	80.41
100.09	162	15.54	0.675	18.589	0.9585	80.74
90.08	176	15.51	0.671	18.584	0.9761	80.40
80.07	178	14.04	0.611	18.412	0.9811	80.13
70.06	170	11.79	0.521	18.167	0.9875	80.28
60.05	162	9.68	0.430	17.983	0.9899	79.88
50.04	151	7.55	0.338	17.738	0.9947	79.41
40.03	138	5.51	0.245	17.503	0.9974	77.83
30.02	116	3.48	0.152	17.085	0.9979	74.62
20.01	77	1.52	0.058	16.420	0.9956	62.66

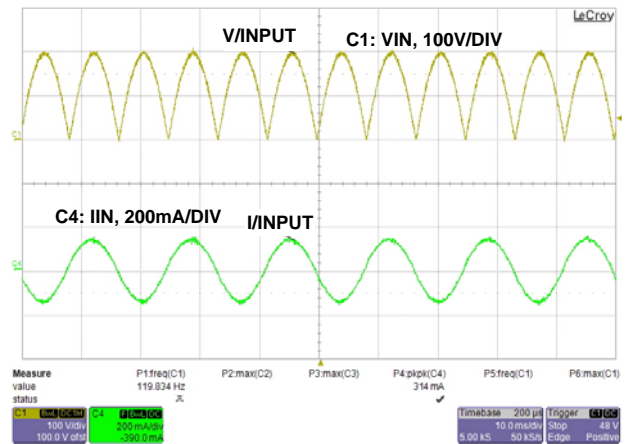

FIGURE 12. INPUT VOLTAGE AND CURRENT @ 140V

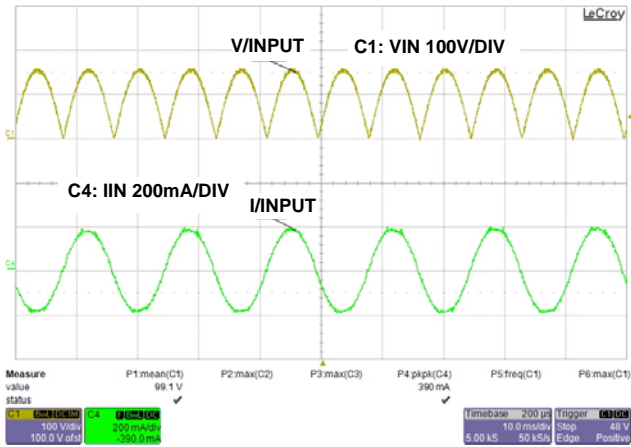

FIGURE 13. INPUT VOLTAGE AND CURRENT @ 110V

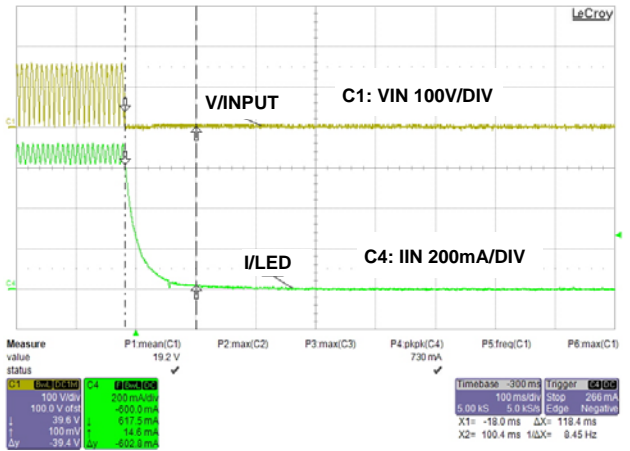

FIGURE 16. FAST TURN-OFF @ 110V

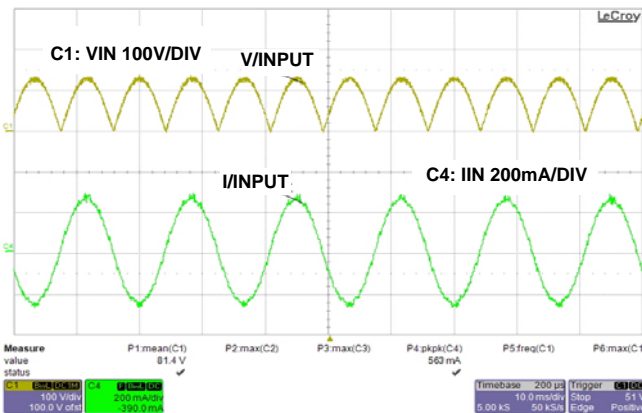

FIGURE 14. INPUT VOLTAGE AND CURRENT @ 90V

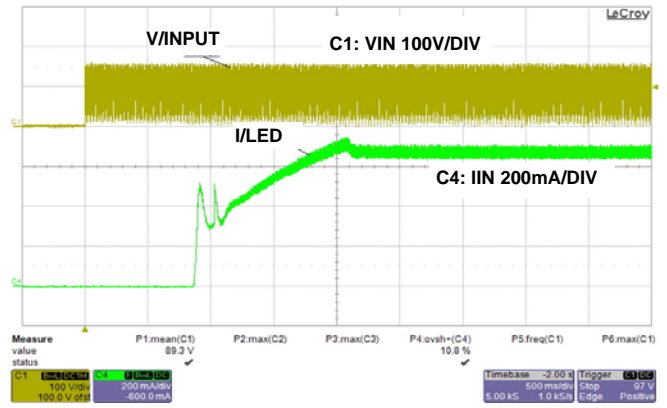

FIGURE 17. TURN ON OVER-SHOT @ 110V

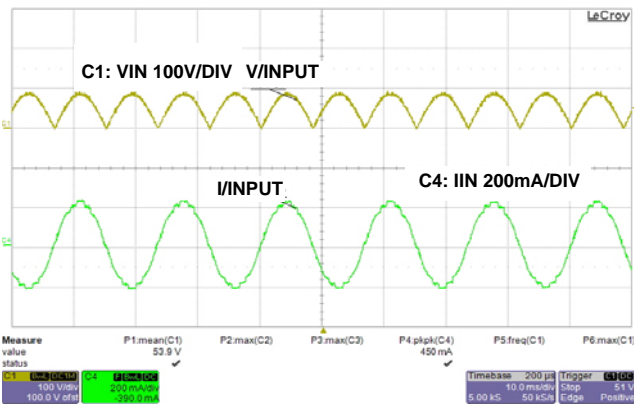

FIGURE 15. INPUT VOLTAGE AND CURRENT @ 60V

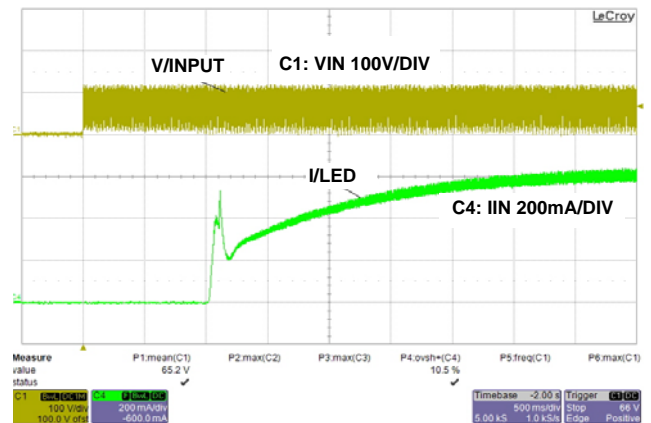

FIGURE 18. TURN ON OVER-SHOT @ 80V

Typical Performance Characteristics with Dimmer

See “Schematic With/Without Triac Dimming Compatible” on page 8, tables 5 and 6. Connect the P1 and P2 of the LED driver board to the AC power supply. A string of 6 Cree high power white LEDs is connected to the output terminal of the LED driver board. The efficiency of the driver is shown in Table 2 for 110V input.

The operation waveforms are shown in Figures 19 to 24, respectively. Figures 19 to 22 show the rectified input voltage and current for different inputs. Figures 23 and 24 show the overshoot of the LED. Current is greatly reduced with the delayed start-up circuit.

TABLE 2. EFFICIENCY AND POWER FACTOR WITH DIMMER

PHASE WIDTH (ms)	POWER INPUT (W)	I LED (mA)	V LED (V)	PF	EFF (%)
7.436	16.99	0.671	18.332	0.99	72.40
5.844	15.064	0.600	18.011	0.94	71.74
5.212	12.428	0.501	17.777	0.87	71.66
4.512	10.212	0.401	17.608	0.75	69.14
3.984	7.758	0.300	17.443	0.64	67.45
3.404	5.100	0.200	17.182	0.51	67.38
2.588	2.629	0.093	16.724	0.35	59.16
1.808	0.756	0.015	15.851	0.17	31.45

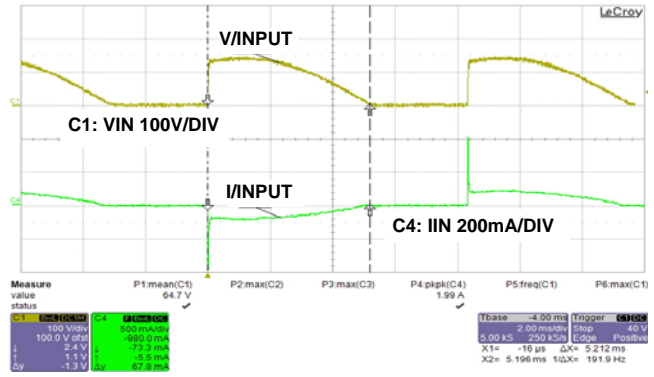

FIGURE 20. PHASE CONTROLLED VOLTAGE AND INPUT CURRENT

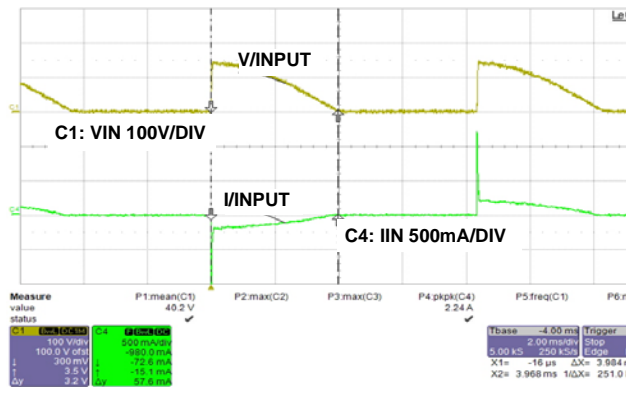

FIGURE 21. PHASE CONTROLLED VOLTAGE AND INPUT CURRENT

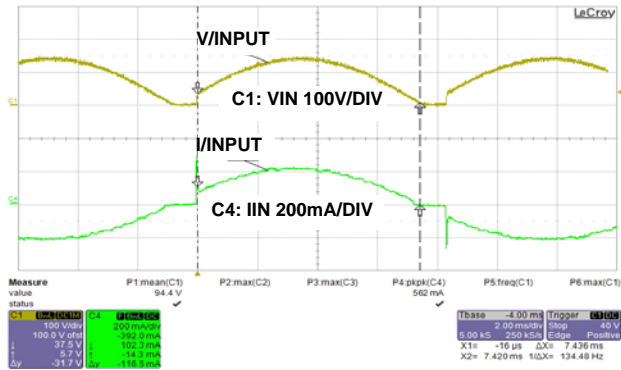

FIGURE 19. PHASE CONTROLLED VOLTAGE AND INPUT CURRENT

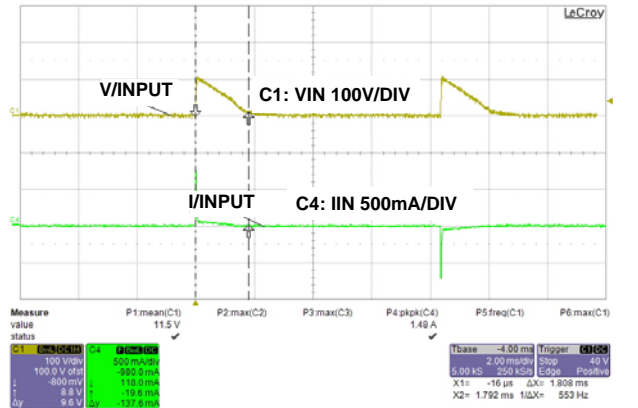

FIGURE 22. PHASE CONTROLLED VOLTAGE AND INPUT CURRENT

Thermal Performance Characteristics

The temperature test of the board, and critical components of the driver with/without dimmer is shown in Tables 3 and 4 for 110V input full load conditions.

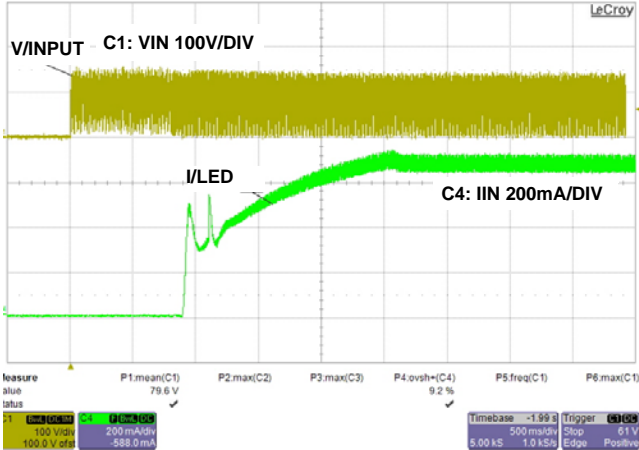

FIGURE 23. OVERSHOT OF LED CURRENT (672mA, 9%)

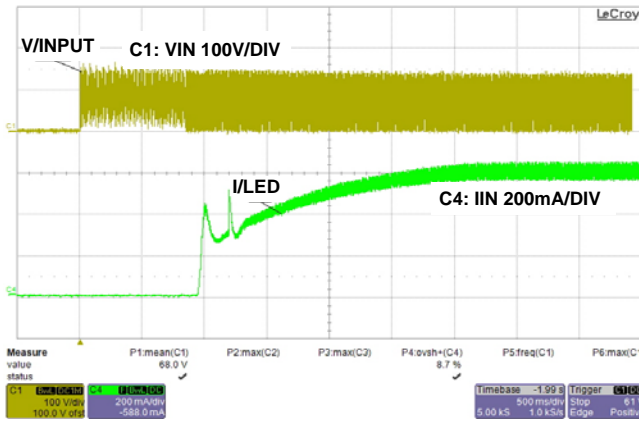

FIGURE 24. OVERSHOT OF LED CURRENT (600mA, 8%)

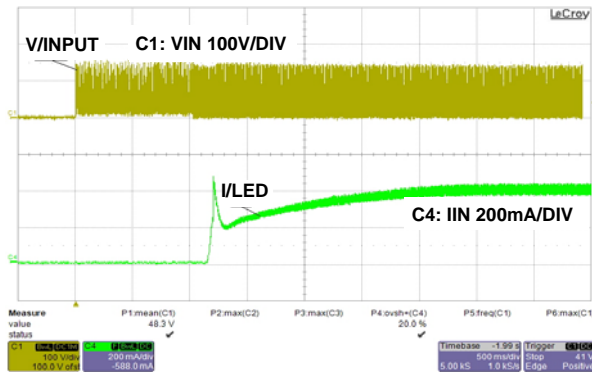

FIGURE 25. OVERSHOT OF LED CURRENT (400mA, 22%)

TABLE 3. CIRCUIT WORK WITHOUT DIMMER FOR 6 LEDS

COMP	T = +85°C	T = +25°C	T = 0°C	T = -40°C
Q1	98	36	11	-30
L1	88	26	3	-35
L2	90	33	3	-34
L3	88	26	3	-37
C4	88	26	3	-37
R4	86	26	0	-37
R12	97	37	13	-26
Q0	89	33	3	-34
CR2	109	49	10	-24
C8	88	29	3	-37

TABLE 4. CIRCUIT WORK WITHOUT DIMMER FOR 6 LEDS

COMP	T = +85°C	T = +25°C	T = 0°C	T = -40°C
Q1	100	38	13	-28
L1	88	30	2	-37
L2	88	30	2	-37
L3	88	28	2	-37
C4	88	28	2	-37
R3	126	84	50	-18
R12	95	37	10	-25
Q0	90	30	5	-34
CR2	92	48	7	-32
C8	88	28	2	-37

References

1. ISL6745A datasheet, Intersil Corporation
2. ISL5420 datasheet, Intersil Corporation
3. ISL6745EVAL2Z Offline High Brightness White LED Driver With High Power Factor for Universal Input, Intersil Corporation application note: AN1411
4. Z. Ye, et al, "Design Considerations of a High Power Factor SEPIC Converter for High Brightness White LED Lighting Applications," IEEE PESC conference record, 2008, June 2008, Greece, pp 2657- 2663.

Schematic With/Without Triac Dimming Compatible

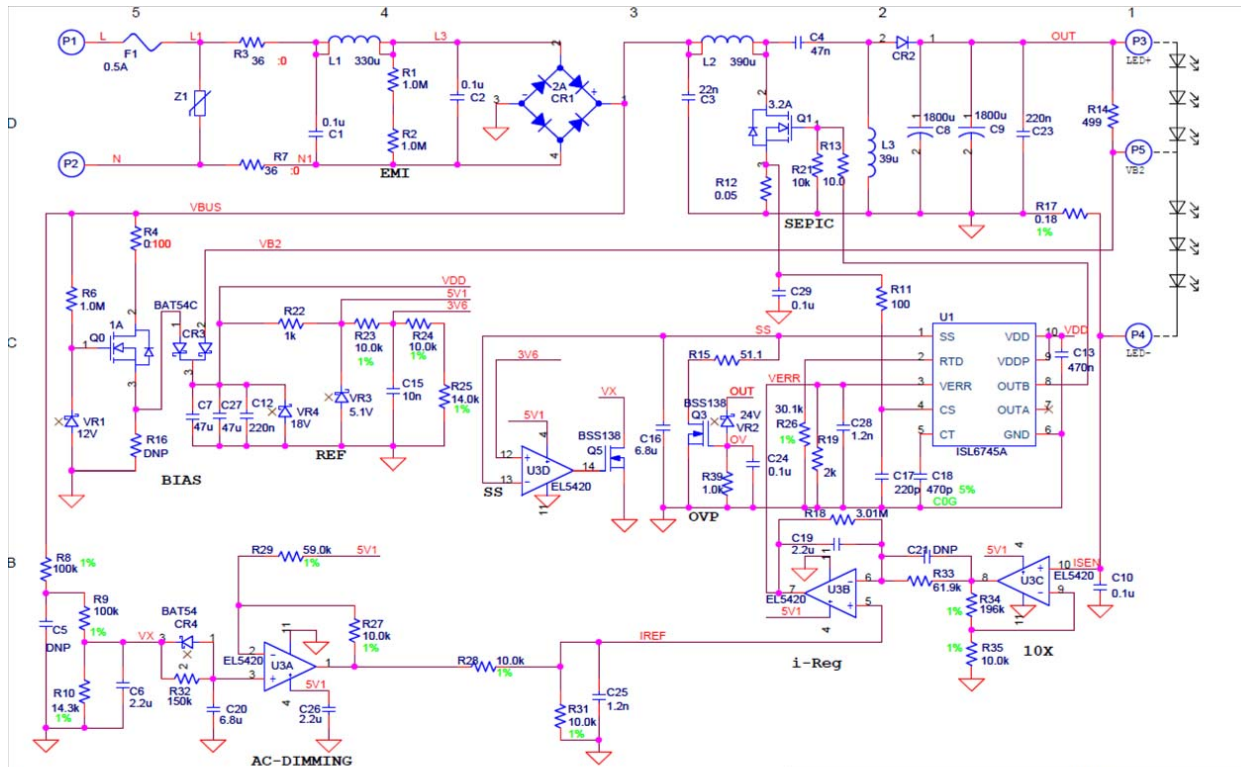

- A NOTES:
- 1) Unless otherwise specified All capacitors are ceramic 16V 0603 10%
 - 2) Take C21 for example, whose value is "DNP:220n", means: for dimming version, Do Not Populate (DNP); for non-dimming version, the value is "220n".
 - 3) For 4 LEDs, VR2 use 12V zener (Vishay MMBZ5239B)



Title Non-Isolated LED Driver with AC-TRIAC Dimming		
Size A	Document Number <Doc>	Rev C
Date: Monday, July 06, 2009	Sheet 1	of 1

Application Note 1487

TABLE 5. ISL6745ALEVAL3Z NON-ISOLATED LED ADAPTOR WITHOUT TRIAC DIMMING

NO.	QTY.	REFERENCE	VALUE	VALUE NO.	PACKAGE	TOL	VOLTAGE (V)	VENDOR	PART NO.
1	1	CR1	2A		BRIDGE RECTIFIER		400	DIODES	2W04G
2	1	CR2	3A		SMC		600	DIODES	RS3J-E3
3	1	CR3	BAT54C		SOT23			DIODES	
4	1	CR4	BAT54		SOT23			DIODES	
5	2	C1, C2	0.1 μ F		X2-CAP		250	PANASONIC	ECQU2A 104ML
6	1	C3	22nF		SM1812		250	TDK	C453C0G2E223J
7	1	C4	47nF		SM1812		250	TDK	C453C0G2E223J
8	1	C5	DNP		SM1210		100	MURATA	
9	1	C6	2.2 μ F		SM0603			MURATA	GRM31CR71H225K
10	2	C7, C27	47 μ F		SM1210			MURATA	GRM32ER61C476ME15L
11	2	C8, C9	1800 μ F		12.5x20mm		25	CHEMI CON	EKZE250ELL182MK30S
12	3	C10, C24, C29	0.1 μ F		SM0603				
13	1	C12	220nF		SM0603				
14	1	C13	470nF		SM0603				
15	1	C15	10nF		SM0603				
16	2	C16, C20	6.8 μ F		SM0805				
17	1	C17	220pF		SM0603				
18	1	C18	470pF		SM0603	NPO/C0G			
19	2	C19, C20	220nF		SM0603				
20	1	C21	DNP	:220n	SM0603				
21	1	C23	220nF		SM0805		25		
22	2	C25, C28	1.2nF		SM0603				
23	1	F1	0.5A		FUSE				TR5
24	1	L1	330 μ F					COILCRAFT	MSS1278-334KLB
25	1	L2	390 μ F				500	COILCRAFT	MSD1278-334KLB
26	1	L3	39 μ F				650	PULSE	PA2050.393NL
27	5	P1, P2, P3, P4, P5	TERMINAL					KEYSTONE	1514-2
28	1	Q0	1A		DPAK			FAIRCHILD	FQD1N50TM
29	1	Q1	3.2A		DPAK			INFINEON	IPD60R385CP
30	2	Q3, Q5	BSS138		SOT23				
31	3	R1, R2, R6	1.0M		SM1206	5%			
32	2	R3, R7	0 Ω		RES-2W	5%			
33	1	R4	100 Ω		SM1206	5%			
34	2	R8, R9	100k Ω		SM1206	1%			
35	1	R10	14.3k Ω		SM0603	1%			
36	1	R11	100 Ω		SM0603	5%			
37	1	R12	0.05 Ω		SM2512	5%			
38	1	R13	10 Ω		SM0805	5%			
39	1	R14	499 Ω		SM1206	5%			

Application Note 1487

TABLE 5. ISL6745ALEVAL3Z NON-ISOLATED LED ADAPTOR WITHOUT TRIAC DIMMING (Continued)

NO.	QTY.	REFERENCE	VALUE	VALUE NO.	PACKAGE	TOL	VOLTAGE (V)	VENDOR	PART NO.
40	1	R15	51.1Ω		SM0805	5%			
41	1	R16	DNP		SM1206	5%			
42	1	R17	0.18Ω		SM1206	1%			
43	1	R18	3.01MΩ		SM0603	5%			
44	1	R19	2kΩ		SM0603	5%			
45	1	R21	10kΩ		SM0603	5%			
46	1	R22	1kΩ		SM1206	5%			
47	6	R23, R24, R27, R28, R31, R32	10.0kΩ		SM0603	1%			
48	1	R25	14.0kΩ		SM0603	1%			
49	1	R26	30.1kΩ		SM0603	1%			
50	1	R29	59.0kΩ		SM0603	1%			
51	1	R32	150kΩ		SM0603	5%			
52	1	R33	61.9kΩ		SM0603	5%			
53	1	R34	196kΩ		SM0603	1%			
54	1	R39	1.0kΩ		SM0603	5%			
55	1	U1	ISL6745A		MSOP10			INTERSIL	ISL6745AAU
56	1	U3	EL5420		TSSOP14			INTERSIL	EL5420CRZ
57	1	VR1	11V		SOT23			DIODES	BZX84C11
58	1	VR2	24V		SOT23			VISHAY	MMBZ5252
59	1	VR3	5.1V		SOT23			DIODES	BZX84B5V1LT1
60	1	VR4	DNP		SOT23			DIODES	BZX84C18
61	1	Z1	-		-			LITTELFUSE	TMOV14R140E

Application Note 1487

TABLE 6. ISL6745ALEVAL3Z NON-ISOLATED LED ADAPTOR WITH TRIAC DIMMING

NO.	QTY.	REFERENCE	VALUE	VALUE NO.	PACKAGE	TOL	VOLTAGE (V)	VENDOR	PART NO.
1	1	CR1	2A		BRIDGE RECTIFIER		400	DIODES	2W04G
2	1	CR2	3A		SMC		600	DIODES	RS3J-E3
3	1	CR3	BAT54C		SOT23			DIODES	
4	1	CR4	BAT54		SOT23			DIODES	
5	2	C1, C2	0.1 μ F		X2-CAP		250	PANASONIC	ECQU2A 104ML
6	1	C3	22nF		SM1812		250	TDK	C453C0G2E223J
7	1	C4	47nF		SM1812		250	TDK	C453C0G2E223J
8	1	C5	DNP		SM1210		100	MURATA	
9	1	C6	2.2 μ F		SM0603			MURATA	GRM31CR71H225K
10	2	C7, C27	47 μ F		SM1210			MURATA	GRM32ER61C476ME15L
11	2	C8, C9	1800 μ F		12.5x20mm		25	CHEMI CON	EKZE250ELL182MK30S
12	3	C10, C24, C29	0.1 μ F		SM0603				
13	1	C12	220nF		SM0603				
14	1	C13	470nF		SM0603				
15	1	C15	10nF		SM0603				
16	2	C16, C20	6.8 μ F		SM0805				
17	1	C17	220pF		SM0603				
18	1	C18	470pF		SM0603	NPO/COG			
19	2	C19, C20	220nF		SM0603				
20	1	C21	DNP	:220n	SM0603				
21	1	C23	220nF		SM0805		25		
22	2	C25, C28	1.2nF		SM0603				
23	1	F1	0.5A		FUSE				TR5
24	1	L1	330 μ H					COILCRAFT	MSS1278-334KLB
25	1	L2	390 μ H				500	COILCRAFT	MSD1278-334KLB
26	1	L3	39 μ H				650	PULSE	PA2050.393NL
27	5	P1, P2, P3, P4, P5	TERMINAL					KEYSTONE	1514-2
28	1	Q0	1A		DPAK			FAIRCHILD	FQD1N50TM
29	1	Q1	3.2A		DPAK			INFINEON	IPD60R385CP
30	2	Q3, Q5	BSS138		SOT23				
31	3	R1, R2, R6	1.0M Ω		SM1206	5%			
32	2	R3, R7	36 Ω		RES-2W	5%			
33	1	R4	0 Ω		SM1206	5%			
34	2	R8, R9	100k Ω		SM1206	1%			
35	1	R10	14.3k Ω		SM0603	1%			
36	1	R11	100 Ω		SM0603	5%			
37	1	R12	0.05 Ω		SM2512	5%			
38	1	R13	10 Ω		SM0805	5%			
39	1	R14	499 Ω		SM1206	5%			

Application Note 1487

TABLE 6. ISL6745ALEVAL3Z NON-ISOLATED LED ADAPTOR WITH TRIAC DIMMING (Continued)

NO.	QTY.	REFERENCE	VALUE	VALUE NO.	PACKAGE	TOL	VOLTAGE (V)	VENDOR	PART NO.
40	1	R15	51.1Ω		SM0805	5%			
41	1	R16	DNP		SM1206	5%			
42	1	R17	0.18Ω		SM1206	1%			
43	1	R18	3.01MΩ		SM0603	5%			
44	1	R19	2kΩ		SM0603	5%			
45	1	R21	10kΩ		SM0603	5%			
46	1	R22	1kΩ		SM1206	5%			
47	6	R23, R24, R27, R28, R31, R32	10.0kΩ		SM0603	1%			
48	1	R25	14.0kΩ		SM0603	1%			
49	1	R26	30.1kΩ		SM0603	1%			
50	1	R29	59.0kΩ		SM0603	1%			
51	1	R32	150kΩ		SM0603	5%			
52	1	R33	61.9kΩ		SM0603	5%			
53	1	R34	196kΩ		SM0603	1%			
54	1	R39	1.0kΩ		SM0603	5%			
55	1	U1	ISL6745A		MSOP10			INTERSIL	ISL6745AAU
56	1	U3	EL5420		TSSOP14			INTERSIL	EL5420CRZ
57	1	VR1	11V		SOT23			DIODES	BZX84C11
58	1	VR2	24V		SOT23			VISHAY	MMBZ5252
59	1	VR3	5.1V		SOT23			DIODES	BZX84B5V1LT1
60	1	VR4	DNP		SOT23			DIODES	BZX84C18
61	1	Z1	-		-			LITTELFUSE	TMOV14R140E

Intersil Corporation reserves the right to make changes in circuit design, software and/or specifications at any time without notice. Accordingly, the reader is cautioned to verify that the Application Note or Technical Brief is current before proceeding.

For information regarding Intersil Corporation and its products, see www.intersil.com