

Cree® XLamp® XP-E High-Efficiency White LEDs

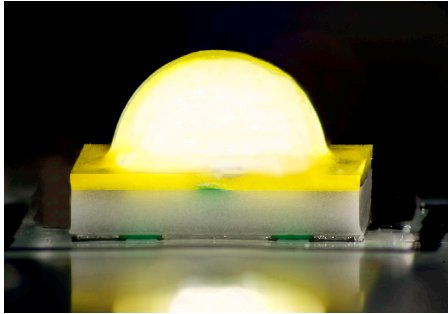

PRODUCT DESCRIPTION

XLamp XP-E High-Efficiency White LEDs upgrade the XLamp XP-E to leading performance levels for diffuse lighting applications. XP-E HEW is designed to enable faster adoption of LED light in cost-sensitive, consumer lighting products. Compared to the standard XLamp XP-E, XP-E HEW can reduce LED count by 50% and still deliver the same system performance.

Cree XLamp LEDs bring high performance and quality of light to a wide range of lighting applications, including color-changing, portable and personal, outdoor, indoor-directional, transportation, stage and studio, commercial and emergency-vehicle lighting.

FEATURES

- Light output and efficacy similar to XLamp XP-G
- Maximum drive current: 1000 mA
- Low thermal resistance: 6°C/W
- Maximum junction temperature: 150°C
- Wide viewing angle: 120°
- Reflow solderable - JEDEC J-STD-020C compatible
- Electrically neutral thermal path

TABLE OF CONTENTS

Flux Characteristics	
(T _J = 25°C) - White	2
Characteristics	3
Relative Spectral Power	
Distribution	3
Relative Flux vs. Junction	
Temperature (I _F = 350 mA)	4
Electrical Characteristics	
(T _J = 25°C)	5
Thermal Design	5
Relative Flux vs. Current	
(T _J = 25°C)	6
Typical Spatial Distribution	6
Reflow Soldering Characteristics	7
Notes	8
Mechanical Dimensions	
(T _A = 25°C)	9
Tape and Reel	10
Packaging	11

FLUX CHARACTERISTICS (T_j = 25°C) - WHITE

The following table provides several base order codes for XLamp XP-E HEW LEDs. It is important to note that the base order codes listed here are a subset of the total available order codes for the product family. For more order codes, as well as a complete description of the order-code nomenclature, please consult the XLamp XP Family Binning and Labeling document.

Color	CCT Range		Base Order Codes Min Luminous Flux @ 350 mA (lm)		Order Code
	Min.	Max.	Group	Flux (lm)	
Cool White	5,000 K	8,300 K	R3	122	XPEHEW-L1-0000-00F51
			R4	130	XPEHEW-L1-0000-00G51
Outdoor White	2,600 K	5,300 K	R2	114	XPEHEW-01-0000-00EC2
			R3	122	XPEHEW-01-0000-00FC2
Neutral White	3,700 K	5,000 K	Q5	107	XPEHEW-L1-0000-00DE4
			R2	114	XPEHEW-L1-0000-00EE4
80-CRI White	2,600 K	4,300 K	Q3	93.9	XPEHEW-H1-0000-00BE7
			Q4	100	XPEHEW-H1-0000-00CE7
Warm White	2,600 K	3,700 K	Q3	93.9	XPEHEW-L1-0000-00BE7
			Q4	100	XPEHEW-L1-0000-00CE7
85-CRI White	2,600 K	3,200 K	P4	80.6	XPEHEW-P1-0000-009E7
			Q2	87.4	XPEHEW-P1-0000-00AE7
90-CRI White	2,600 K	3,200 K	P4	80.6	XPEHEW-U1-0000-009E7

Notes:

- Cree maintains a tolerance of $\pm 7\%$ on flux and power measurements and ± 2 on CRI measurements.
- Typical CRI for Cool White and Neutral White (3,700 K - 10,000 K CCT) is 75.
- Typical CRI for Outdoor White (4,000 K - 5,300 K CCT) is 70.
- Typical CRI for Warm White (2,600 K - 3,700 K CCT) is 80.
- Minimum CRI for 80-CRI White is 80.
- Minimum CRI for 85-CRI White is 85.
- Minimum CRI for 90-CRI White is 90.

CHARACTERISTICS

Characteristics	Unit	Minimum	Typical	Maximum
Thermal Resistance, junction to solder point - white	°C/W		6	
Viewing Angle (FWHM) - white	degrees		120	
Temperature coefficient of voltage - white	mV/°C		-3	
ESD Classification (HBM per Mil-Std-883D)			Class 2	
DC Forward Current - white	mA			1000
Reverse Voltage	V			5
Forward Voltage (@ 350 mA) - white	V		3.0	3.5
Forward voltage (@ 700 mA) - white	V		3.15	
Forward Voltage (@ 1000 mA) - white	V		3.25	
LED Junction Temperature	°C			150

RELATIVE SPECTRAL POWER DISTRIBUTION

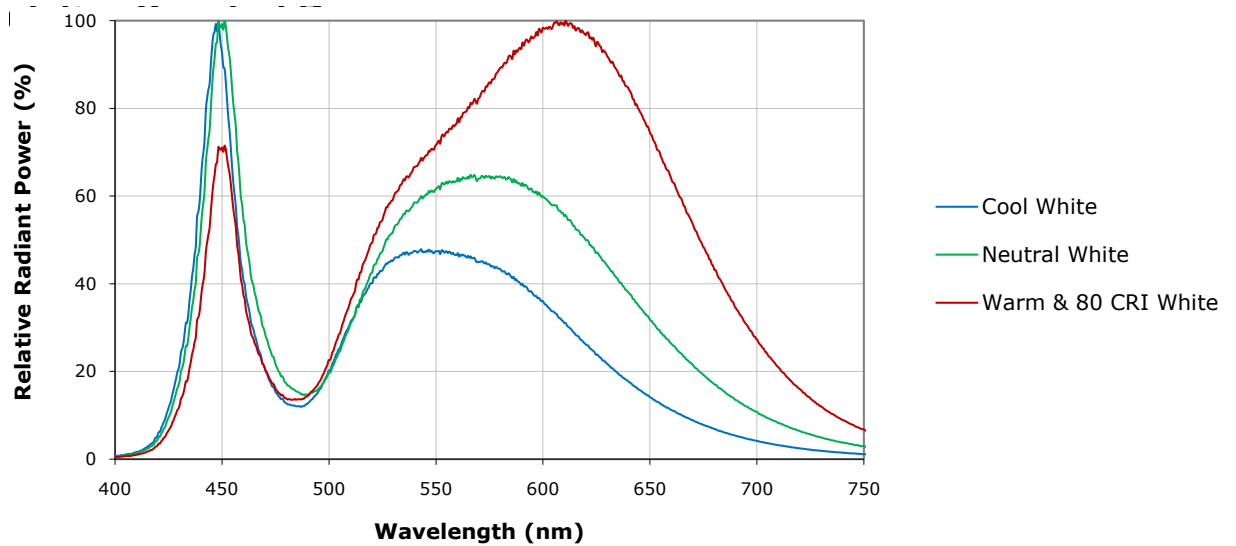

RELATIVE SPECTRAL POWER DISTRIBUTION (CONTINUED)

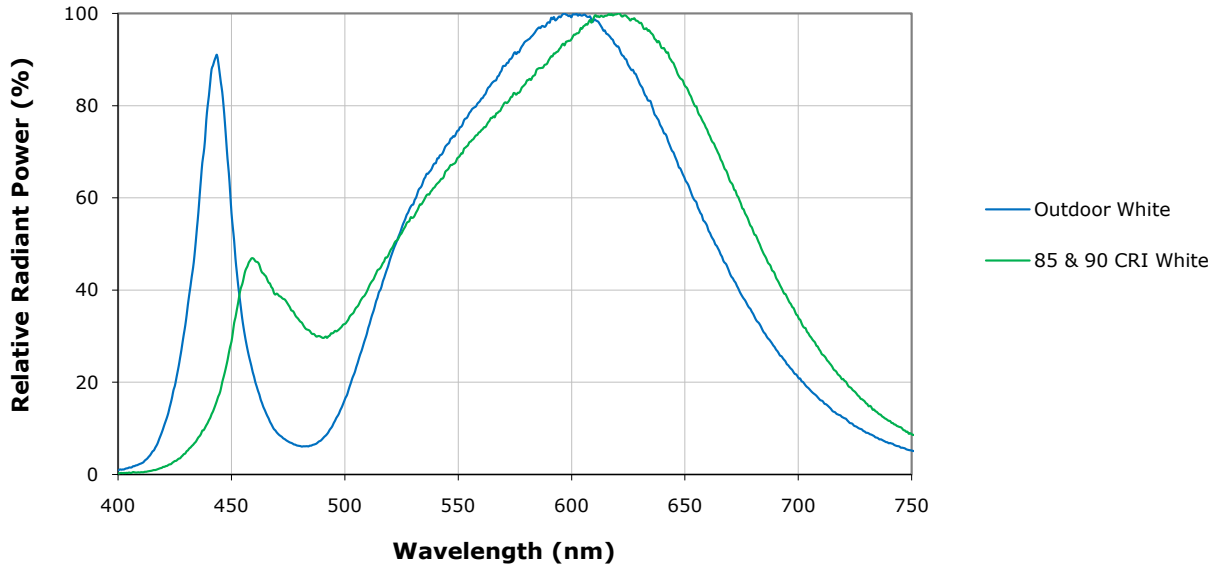

RELATIVE FLUX VS. JUNCTION TEMPERATURE ($I_F = 350 \text{ MA}$)

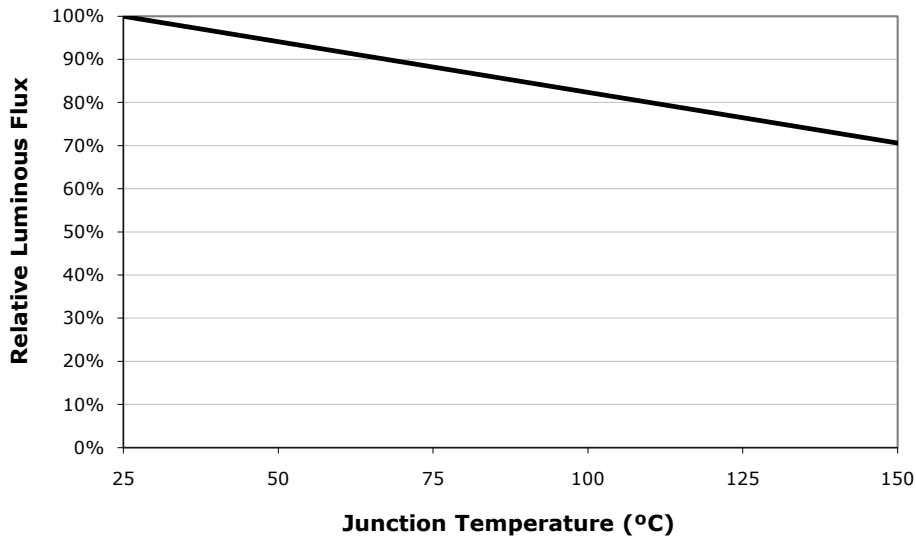

ELECTRICAL CHARACTERISTICS ($T_j = 25^\circ\text{C}$)

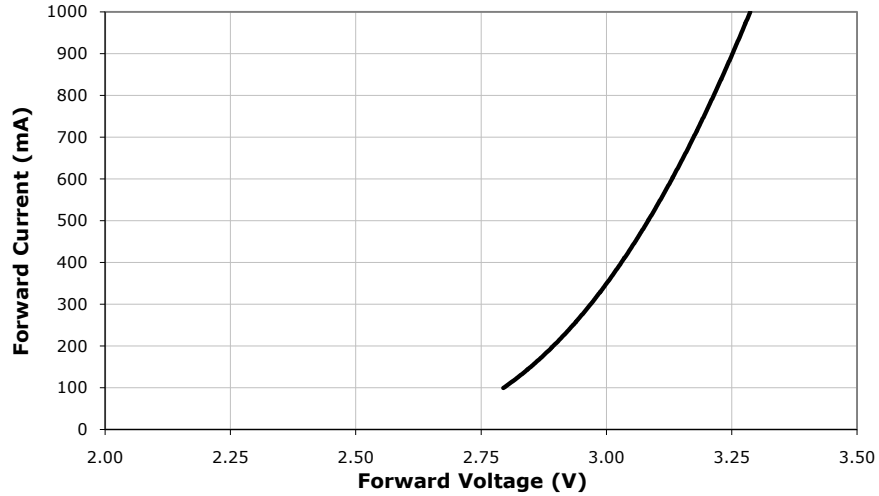

THERMAL DESIGN

The maximum forward current is determined by the thermal resistance between the LED junction and ambient. It is crucial for the end product to be designed in a manner that minimizes the thermal resistance from the solder point to ambient in order to optimize lamp life and optical characteristics.

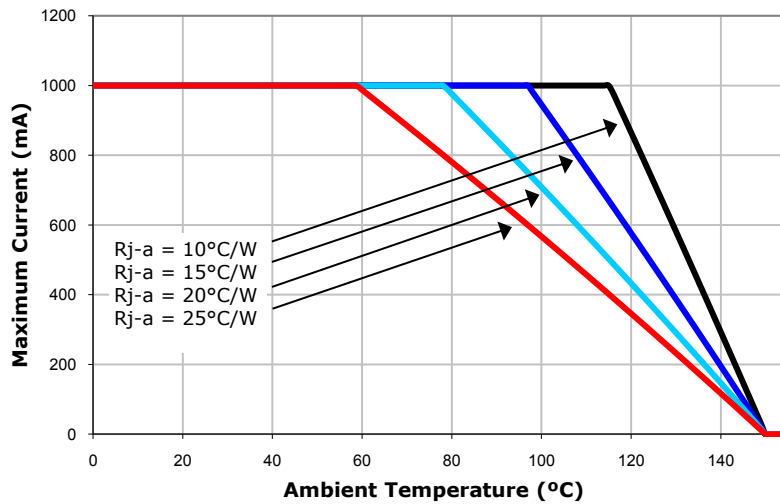

RELATIVE FLUX VS. CURRENT ($T_j = 25^\circ\text{C}$)

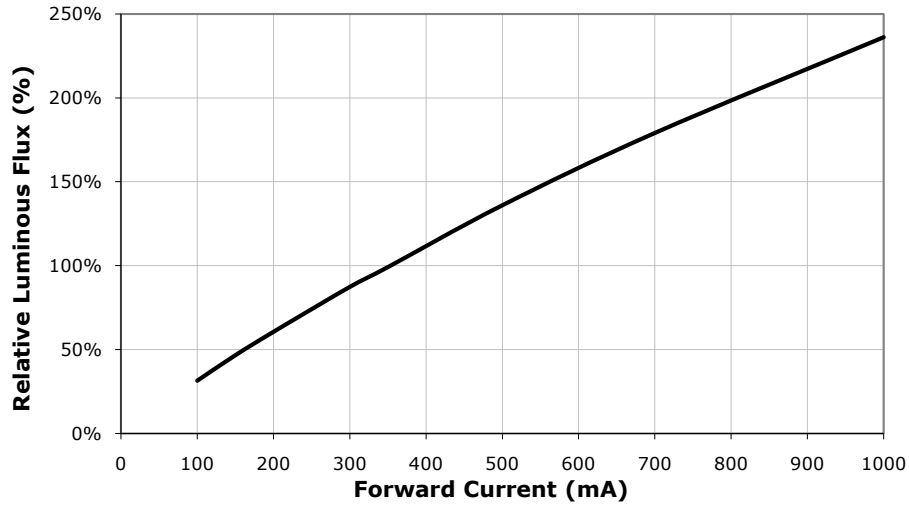

TYPICAL SPATIAL DISTRIBUTION

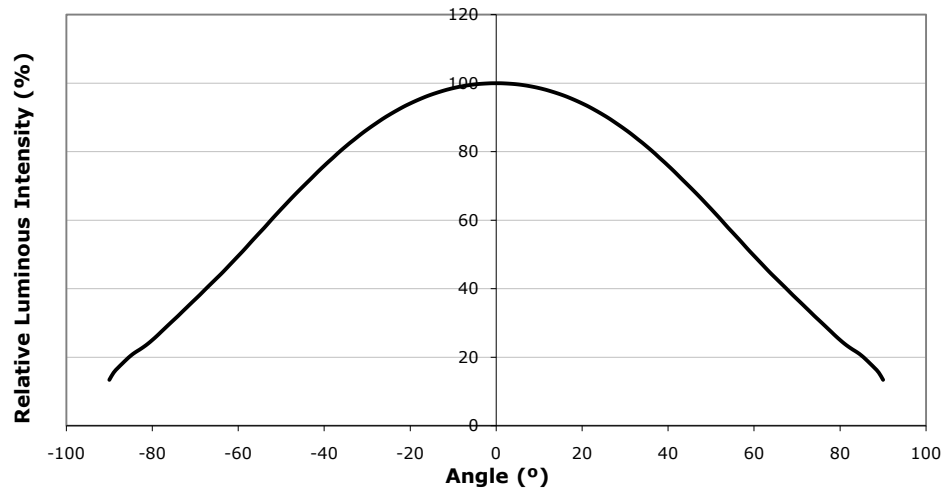

REFLOW SOLDERING CHARACTERISTICS

In testing, Cree has found XLamp XP-E LEDs to be compatible with JEDEC J-STD-020C, using the parameters listed below. As a general guideline, Cree recommends that users follow the recommended soldering profile provided by the manufacturer of solder paste used.

Note that this general guideline may not apply to all PCB designs and configurations of reflow soldering equipment.

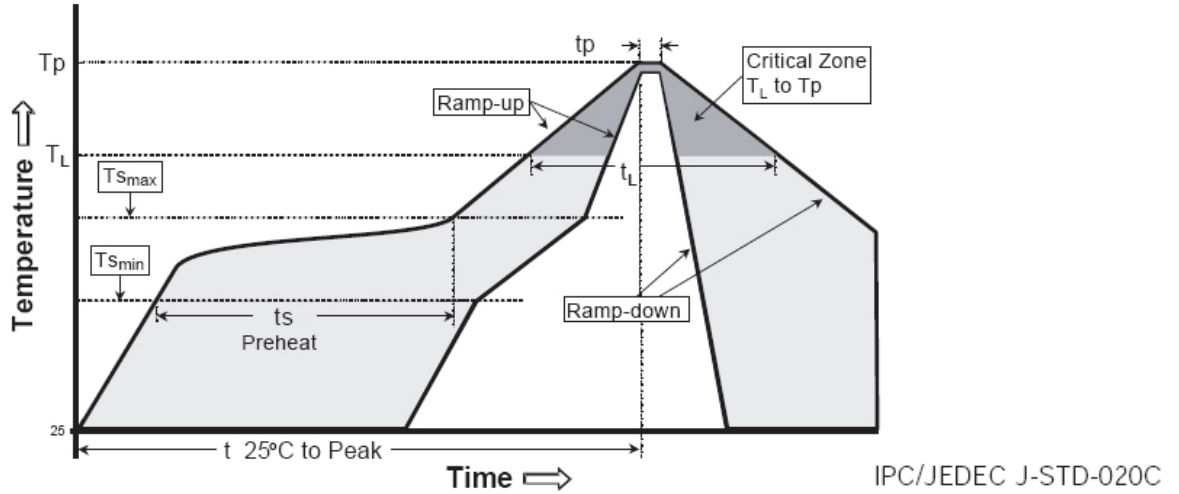

Profile Feature	Lead-Based Solder	Lead-Free Solder
Average Ramp-Up Rate ($T_{s_{max}}$ to T_p)	3°C/second max.	3°C/second max.
Preheat: Temperature Min ($T_{s_{min}}$)	100°C	150°C
Preheat: Temperature Max ($T_{s_{max}}$)	150°C	200°C
Preheat: Time ($t_{s_{min}}$ to $t_{s_{max}}$)	60-120 seconds	60-180 seconds
Time Maintained Above: Temperature (T_l)	183°C	217°C
Time Maintained Above: Time (t_l)	60-150 seconds	60-150 seconds
Peak/Classification Temperature (T_p)	215°C	260°C
Time Within 5°C of Actual Peak Temperature (t_p)	10-30 seconds	20-40 seconds
Ramp-Down Rate	6°C/second max.	6°C/second max.
Time 25°C to Peak Temperature	6 minutes max.	8 minutes max.

Note: All temperatures refer to topside of the package, measured on the package body surface.

Notes

Lumen Maintenance Projections

Cree currently recommends a maximum drive current of 700 mA for XLamp XP-E High Efficiency White in designs seeking the ENERGY STAR* 35,000 hour lifetime rating ($\geq 94.1\%$ luminous flux @ 6000 hours) or 1000 mA driver current in designs seeking the ENERGY STAR* 25,000 hour lifetime rating ($\geq 91.8\%$ luminous flux @ 6000 hours).

Please read the XLamp Long-Term Lumen Maintenance application note for more details on Cree's lumen maintenance testing and forecasting. Please read the XLamp Thermal Management application note for details on how thermal design, ambient temperature, and drive current affect the LED junction temperature.

* These lifetime ratings are based on the current ENERGY STAR Solid State Lighting Luminaires V1.1 (December 12, 2008) and ENERGY STAR Integral LED Lamps V1.0 (December 3, 2009) lumen maintenance criteria.

Moisture Sensitivity

In testing, Cree has found XLamp XP-E LEDs to have unlimited floor life in conditions $\leq 30^{\circ}\text{C}$ / 85% relative humidity (RH). Moisture testing included a 168 hour soak at 85°C / 85% RH followed by 3 reflow cycles, with visual and electrical inspections at each stage.

RoHS Compliance

The levels of environmentally sensitive, persistent biologically toxic (PBT), persistent organic pollutants (POP), or otherwise restricted materials in this product are below the maximum concentration values (also referred to as the threshold limits) permitted for such substances, or are used in an exempted application, in accordance with EU Directive 2002/95/EC on the restriction of the use of certain hazardous substances in electrical and electronic equipment (RoHS), as amended through April 21, 2006.

Vision Advisory Claim

Users should be cautioned not to stare at the light of this LED product. The bright light can damage the eye.

MECHANICAL DIMENSIONS (T_A = 25°C)

All measurements are ±.13 mm unless otherwise indicated.

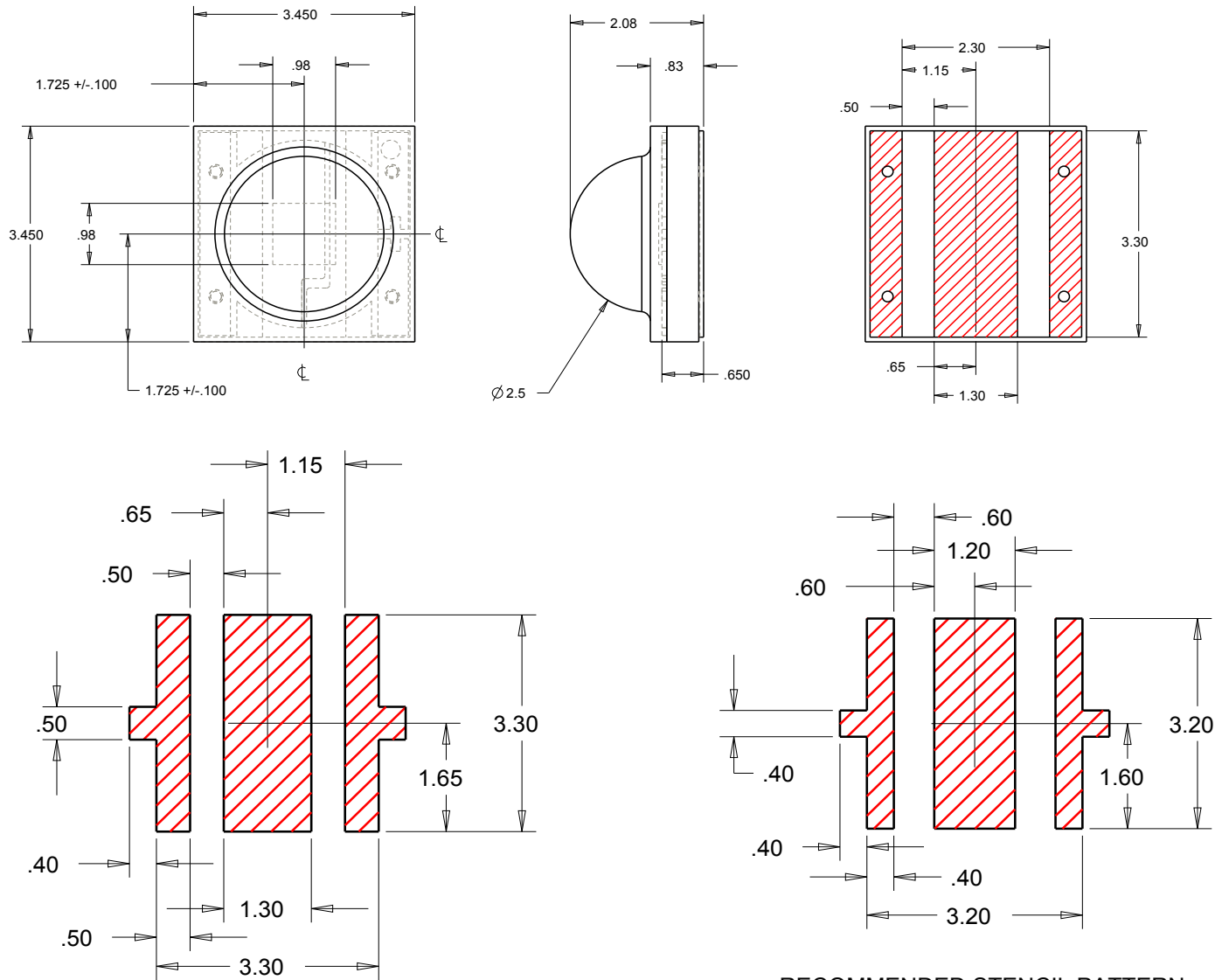

RECOMMENDED PCB SOLDER PAD

RECOMMENDED STENCIL PATTERN
(HATCHED AREA IS OPENING)

TAPE AND REEL

All dimensions in mm.

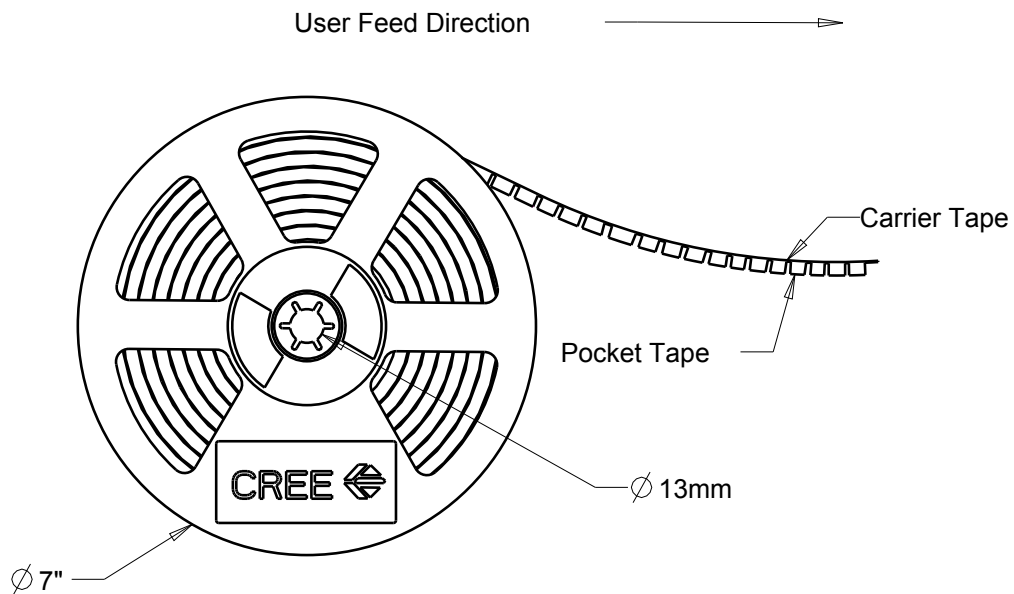
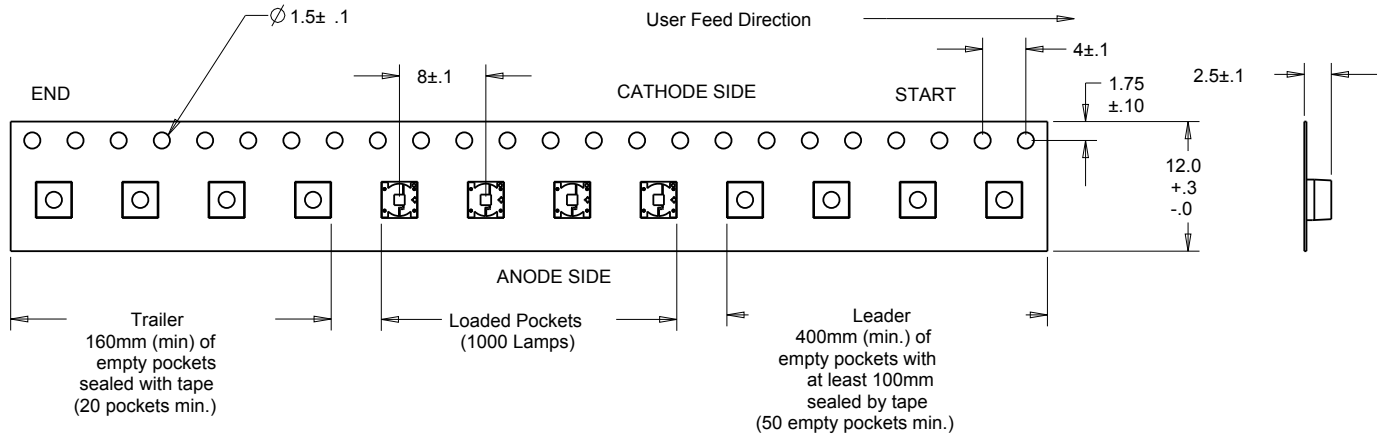

PACKAGING

All dimensions in mm.

