

500mA, Low Dropout, Low Noise Ultra-Fast With Soft Start CMOS LDO Regulator

General Description

The RT9020 is a high-performance, 500mA LDO regulator, offering extremely high PSRR and ultra-low dropout, ideal for portable RF and wireless applications with demanding performance and space requirements.

The RT9020 quiescent current is as low as 25µA, further prolonging the battery life. The RT9020 also works with low-ESR ceramic capacitors, reducing the amount of board space necessary for power applications, critical in hand-held wireless devices.

The RT9020 consumes typical 0.7µA in shutdown mode and has fast turn-on time less than 70µs (without C_{SS}). The other features include ultra-low dropout voltage, high output accuracy, current limiting protection, and high ripple rejection ratio. Tiny packages SOT-23-5 and SC-70-5 are available.

Ordering Information

RT9020-□□□□	
	Package Type
	B : SOT-23-5
	U5 : SC-70-5
	Operating Temperature Range
	P : Pb Free with Commercial Standard
	G : Green (Halogen Free with Commercial Standard)
	Fixed Output Voltage
	15 : 1.5V
	16 : 1.6V
	⋮
	32 : 3.2V
	33 : 3.3V
	1B : 1.25V
	1H : 1.85V
	2H : 2.85V

Note :

Richtek Pb-free and Green products are :

- ▶ RoHS compliant and compatible with the current requirements of IPC/JEDEC J-STD-020.
- ▶ Suitable for use in SnPb or Pb-free soldering processes.

Features

- Wide Operating Voltage Ranges : 2.2V to 5.5V
- Low Dropout : 250mV at 500mA
- 5mA Discharge Current of V_{OUT} when IC Shutdown
- Ultra-Low-Noise for DSC Application
- Ultra-Fast Response in Line/Load Transient
- Current Limiting Protection
- Thermal Shutdown Protection
- High Power Supply Rejection Ratio
- Output Only 1µF Capacitor Required for Stability
- TTL-Logic-Controlled Shutdown Input
- RoHS Compliant and 100% Lead (Pb)-Free

Applications

- Digital Still Camera
- CDMA/GSM Cellular Handsets
- Portable Information Appliances
- Laptop, Palmtops, Notebook Computers
- Mini PCI & PCI-Express Cards
- PCMCIA & New Cards

Marking Information

For marking information, contact our sales representative directly or through a Richtek distributor located in your area, otherwise visit our website for detail.

Pin Configurations

TOP VIEW

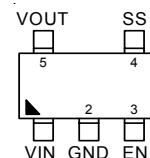

SOT-23-5 / SC-70-5

Typical Application Circuit

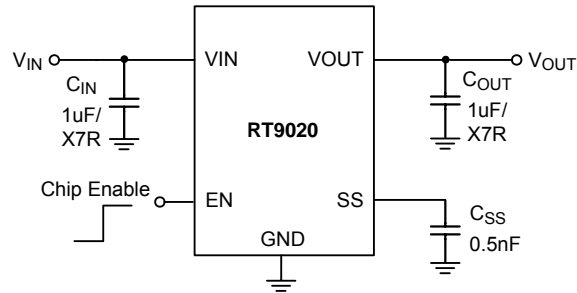

Functional Pin Description

Pin Number	Pin Name	Pin Function
1	VIN	Supply Input.
2	GND	Common Ground.
3	EN	Enable Input Logic, Active High. When the EN goes to a logic low, the device will be shutdown.
4	SS	Soft Start.
5	VOUT	Regulator Output.

Function Block Diagram

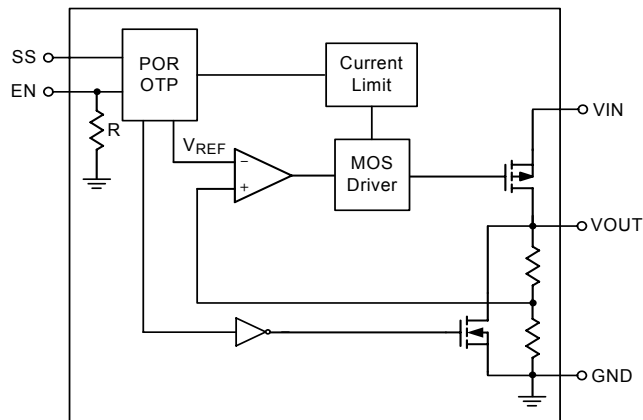

Absolute Maximum Ratings (Note 1)

- Supply Input Voltage ----- 6V
- EN Input Voltage ----- 6V
- Power Dissipation, P_D @ $T_A = 25^\circ\text{C}$
 - SOT-23-5 ----- 0.4W
 - SC-70-5 ----- 0.3W
- Package Thermal Resistance (Note 4)
 - SOT-23-5, θ_{JA} ----- 250°C/W
 - SC-70-5, θ_{JA} ----- 333°C/W
- Lead Temperature (Soldering, 10 sec.) ----- 260°C
- Junction Temperature ----- 150°C
- Storage Temperature Range ----- -65°C to 150°C
- ESD Susceptibility (Note 2)
 - HBM ----- 2kV
 - MM ----- 200V

Recommended Operating Conditions (Note 3)

- Supply Input Voltage ----- 2.2V to 5.5V
- Junction Temperature Range ----- -40°C to 125°C
- Ambient Temperature Range ----- -40°C to 85°C

Electrical Characteristics

($V_{IN} = V_{OUT} + 0.5V$, $V_{EN} = V_{IN}$, $C_{IN} = C_{OUT} = 1\mu\text{F}$ (Ceramic), $T_A = 25^\circ\text{C}$ unless otherwise specified)

Parameter	Symbol	Test Conditions	Min	Typ	Max	Units
Input Voltage Range	V_{IN}		2.2	--	5.5	V
Output Noise Voltage	V_{ON}	$V_{OUT} = 1.5V$, $C_{OUT} = 1\mu\text{F}$, $I_{OUT} = 0\text{mA}$, $C_{SS} = 1\text{nF}$	--	40	--	μV_{RMS}
Output Voltage Accuracy (Fixed Output Voltage)	ΔV_{OUT}	$I_{OUT} = 10\text{mA}$	-2	0	+2	%
Quiescent Current (Note 5)	I_Q	$V_{EN} = 5V$, $I_{OUT} = 0\text{mA}$	--	25	50	μA
Standby Current	I_{STBY}	$V_{EN} = 0V$	--	0.7	1.5	μA
Current Limit	I_{LIM}	$R_{\text{LOAD}} = 0\Omega$, $2.2V \leq V_{IN} < 2.6V$	0.4	0.7	1.05	A
		$R_{\text{LOAD}} = 0\Omega$, $2.7V \leq V_{IN} \leq 5.5V$	0.5	0.8	1.05	A
Dropout Voltage (Note 6)	V_{DROP}	$I_{OUT} = 400\text{mA}$, $2.2V \leq V_{IN} < 2.7V$	--	160	320	mV
		$I_{OUT} = 500\text{mA}$, $2.7V \leq V_{IN} \leq 5.5V$	--	250	400	
Load Regulation (Note 7) (Fixed Output Voltage)	ΔV_{LOAD}	$1\text{mA} < I_{OUT} < 400\text{mA}$ $2.2V \leq V_{IN} < 2.7V$	--	--	0.6	%
		$1\text{mA} < I_{OUT} < 500\text{mA}$ $2.7V \leq V_{IN} \leq 5.5V$	--	--	1	
Soft Start Time		$V_{OUT} = 2.5V$, $C_{SS} = 1\text{nF}$	--	0.7	1	ms

To be continued

Parameter		Symbol	Test Conditions	Min	Typ	Max	Units
EN Threshold	Logic-Low Voltage	V_{IL}		0	--	0.6	V
	Logic-High Voltage	V_{IH}		1.6	--	5.5	
Enable Pin Current		I_{EN}		0.1	1	5	μ A
Power Supply Rejection Rate	$f = 10\text{kHz}$	PSRR	$I_{OUT} = 10\text{mA}$	--	-55	--	dB
Line Regulation		ΔV_{LINE}	$V_{IN} = (V_{OUT} + 0.5)$ to 5.5V, $I_{OUT} = 1\text{mA}$	--	0.01	0.2	%/V
Thermal Shutdown Temperature		T_{SD}		--	170	--	$^{\circ}$ C
Thermal Shutdown Hysteresis		ΔT_{SD}		--	30	--	

Note 1. Stresses listed as the above "Absolute Maximum Ratings" may cause permanent damage to the device. These are for stress ratings. Functional operation of the device at these or any other conditions beyond those indicated in the operational sections of the specifications is not implied. Exposure to absolute maximum rating conditions for extended periods may remain possibility to affect device reliability.

Note 2. Devices are ESD sensitive. Handling precaution recommended.

Note 3. The device is not guaranteed to function outside its operating conditions.

Note 4. θ_{JA} is measured in the natural convection at $T_A = 25^{\circ}\text{C}$ on a low effective thermal conductivity test board of JEDEC 51-3 thermal measurement standard.

Note 5. Quiescent, or ground current, is the difference between input and output currents. It is defined by $I_Q = I_{IN} - I_{OUT}$ under no load condition ($I_{OUT} = 0\text{mA}$). The total current drawn from the supply is the sum of the load current plus the ground pin current.

Note 6. The dropout voltage is defined as $V_{IN} - V_{OUT}$, which is measured when V_{OUT} is $V_{OUT(NORMAL)} - 100\text{mV}$.

Note 7. Regulation is measured at constant junction temperature by using a 2ms current pulse. Devices are tested for load regulation in the load range from 10mA to 500mA.

Typical Operating Characteristics

($C_{IN} = C_{OUT} = 1\mu F/X7R$, $C_{SS} = 1nF$, unless otherwise specified)

Output Voltage vs. Temperature

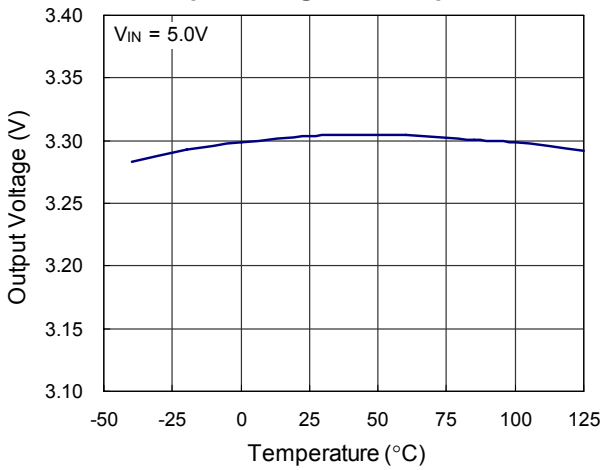

Dropout Voltage vs. Load Current

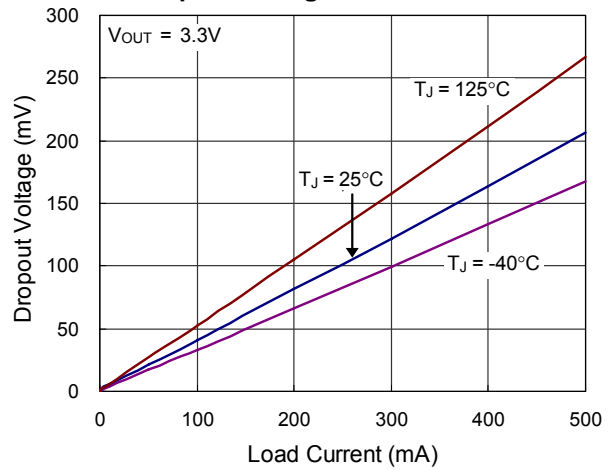

Quiescent Current vs. Temperature

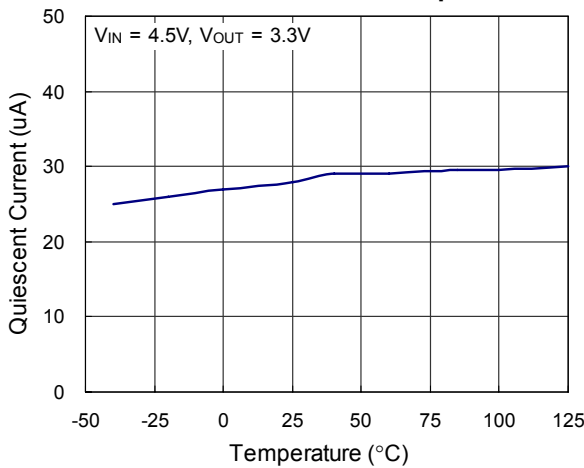

Soft Start Time

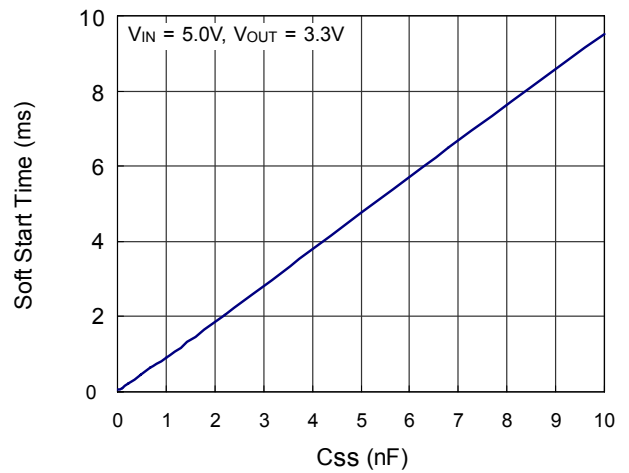

Start Up

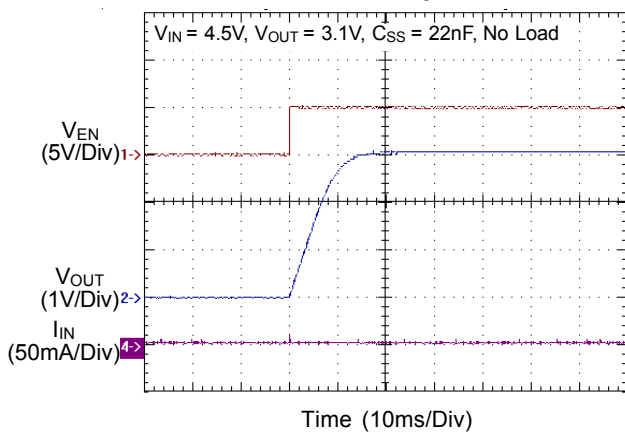

EN Pin Shutdown Response

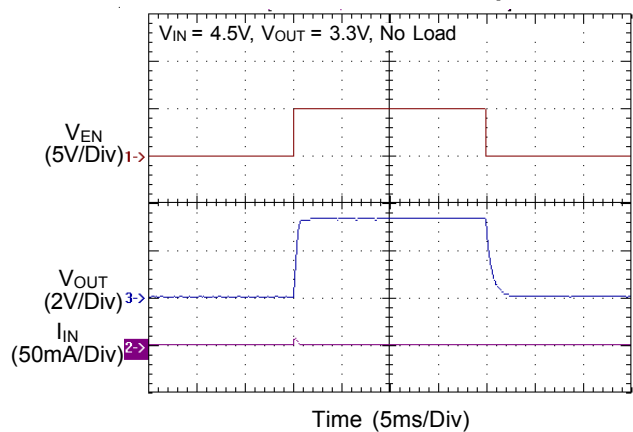

Load Transient Response

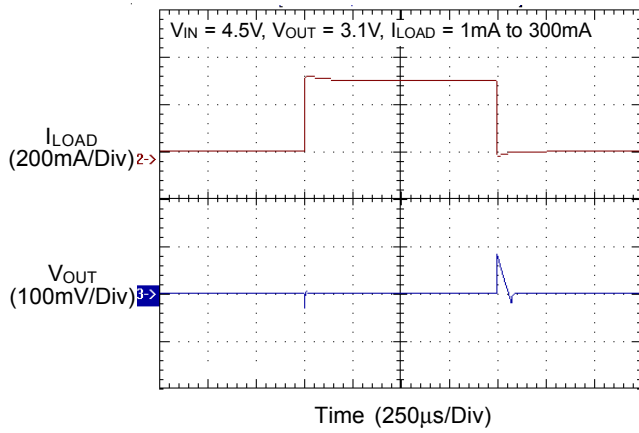

Load Transient Response

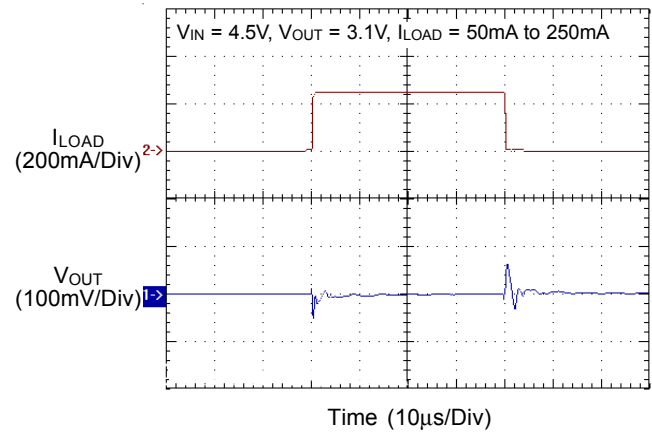

Line Transient Response

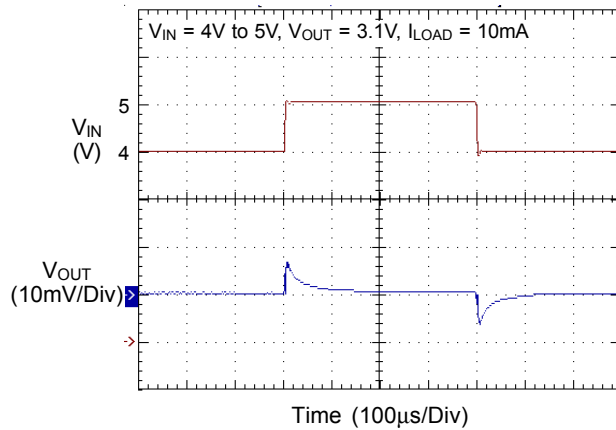

Line Transient Response

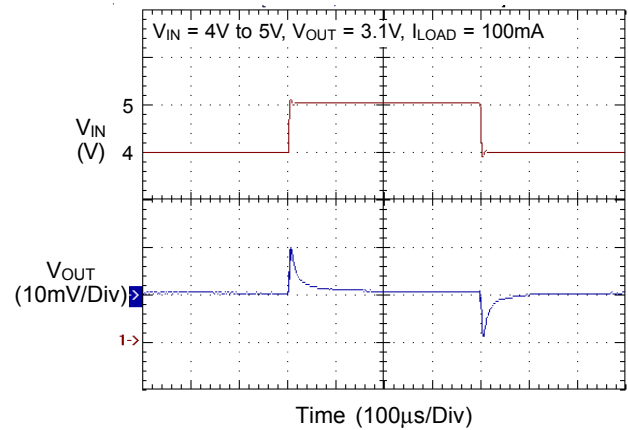

PSRR

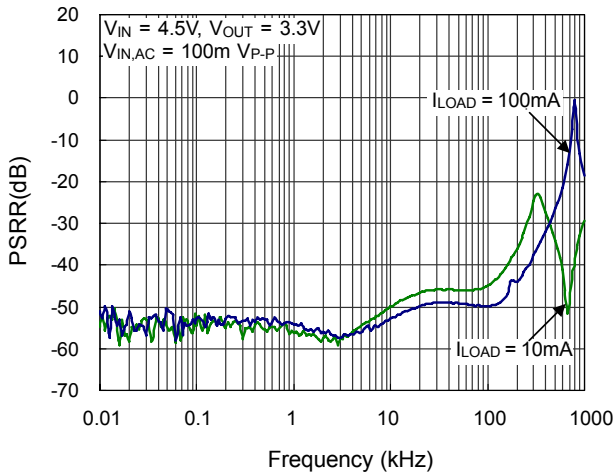

Noise

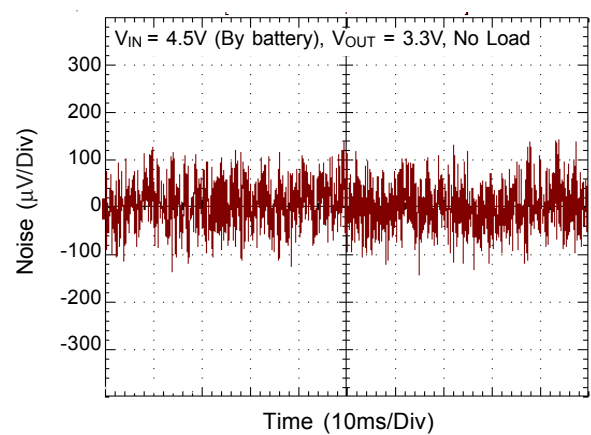

Applications Information

Like any low-dropout regulator, the external capacitors used with the RT9020 must be carefully selected for regulator stability and performance. The recommended input and output capacitors should be 1µF or greater X7R/X5R ceramic. The input capacitor must be located a distance not more than 0.5 inch from the input pin of the IC and returned to a clean analog ground. The capacitor with larger value and lower ESR (equivalent series resistance) provides better PSRR and line-transient response.

The output capacitor must meet both requirements for minimum amount of capacitance and ESR in all LDOs application. The RT9020 is designed specifically to work with low ESR ceramic output capacitor in space-saving and performance consideration. Using a ceramic capacitor whose value is at least 1µF with ESR > 20mΩ on the RT9020 output ensures stability. The RT9020 still works well with output capacitor of other types due to the wide stable ESR range. Figure 1. shows the curves of allowable ESR range as a function of load current for various output capacitor values. Output capacitor of larger capacitance can reduce noise and improve load transient response, stability, and PSRR. The output capacitor should be located not more than 0.5 inch from the VOUT pin of the RT9020 and returned to a clean analog ground.

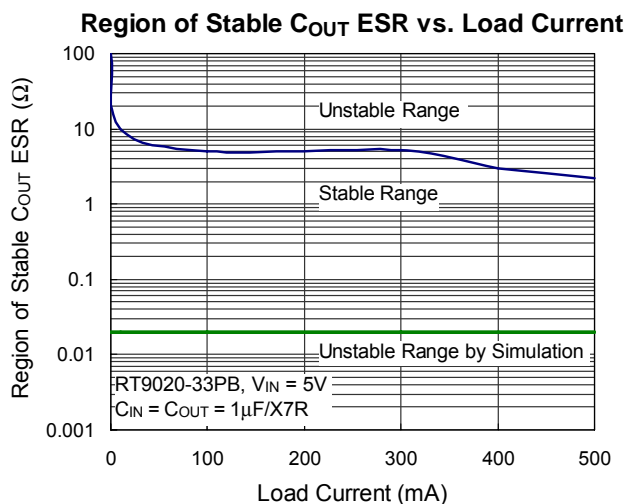

Figure 1

Enable

The RT9020 goes into shutdown mode when the EN pin is in a logic low condition. During this condition, the RT9020 has an EN pin to turn on or turn off regulator. When the EN pin is logic high, the regulator will be turned on. The supply current in shutdown mode is as low as 0.7µA typically. The EN pin may be directly tied to V_{IN} to keep the part on.

PSRR

The power supply rejection ratio (PSRR) is defined as the gain from the input to output divided by the gain from the supply to the output. The PSRR is found to be

$$PSRR = 20 \times \log \left(\frac{\Delta \text{Gain Error}}{\Delta \text{Supply}} \right)$$

Note that when heavy load measuring, Δsupply will cause Δtemperature. And Δtemperature will cause Δoutput voltage change. So the heavy load PSRR measuring includes temperature effect.

Current limit

The RT9020 contains an independent current limiter, which monitors and controls the pass transistor's gate voltage, limiting the output current to 0.7A (typ.). The output can be shorted to ground indefinitely without damaging the part.

Thermal Considerations

Thermal protection limits power dissipation in RT9020. When the operation junction temperature exceeds 170°C, the OTP circuit starts the thermal shutdown function and turns the pass element off. The pass element turn on again after the junction temperature cools by 30°C.

For continuous operation, do not exceed absolute maximum operation junction temperature 125°C. The power dissipation definition in device is :

$$P_D = (V_{IN} - V_{OUT}) \times I_{OUT} + V_{IN} \times I_Q$$

The maximum power dissipation depends on the thermal resistance of IC package, PCB layout, the rate of surroundings airflow and temperature difference between junction to ambient. The maximum power dissipation can be calculated by following formula :

$$P_{D(MAX)} = (T_{J(MAX)} - T_A) / \theta_{JA}$$

Where $T_{J(MAX)}$ is the maximum operation junction temperature, T_A is the ambient temperature and the θ_{JA} is the junction to ambient thermal resistance.

For recommended operating conditions specification of RT9020, where $T_{J(MAX)}$ is the maximum junction temperature of the die (125°C) and T_A is the operated ambient temperature. The junction to ambient thermal resistance θ_{JA} (θ_{JA} is layout dependent) for SOT-23-5 package is 250°C/W and SC-70-5 package is 333°C/W on the standard JEDEC 51-3 single-layer thermal test board. The maximum power dissipation at $T_A = 25^{\circ}\text{C}$ can be calculated by following formula :

$$P_{D(MAX)} = (125^{\circ}\text{C} - 25^{\circ}\text{C}) / 250 = 0.400 \text{ W for SOT-23-5 packages}$$

$$P_{D(MAX)} = (125^{\circ}\text{C} - 25^{\circ}\text{C}) / 333 = 0.300 \text{ W for SC-70-5 packages}$$

The maximum power dissipation depends on operating ambient temperature for fixed $T_{J(MAX)}$ and thermal resistance θ_{JA} . For RT9020 packages, the Figure 2 of derating curves allows the designer to see the effect of rising ambient temperature on the maximum power allowed.

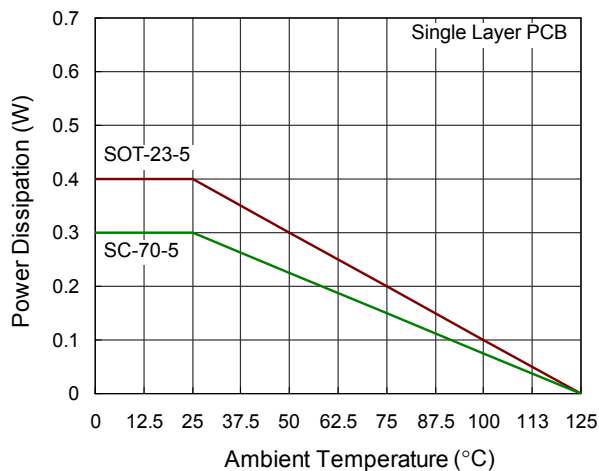
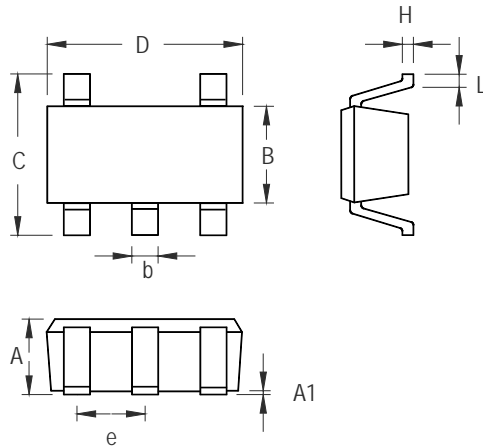

Figure 2. Derating Curves for RT9020 Packages

Outline Dimension



Symbol	Dimensions In Millimeters		Dimensions In Inches	
	Min	Max	Min	Max
A	0.889	1.295	0.035	0.051
A1	0.000	0.152	0.000	0.006
B	1.397	1.803	0.055	0.071
b	0.356	0.559	0.014	0.022
C	2.591	2.997	0.102	0.118
D	2.692	3.099	0.106	0.122
e	0.838	1.041	0.033	0.041
H	0.080	0.254	0.003	0.010
L	0.300	0.610	0.012	0.024

SOT-23-5 Surface Mount Package

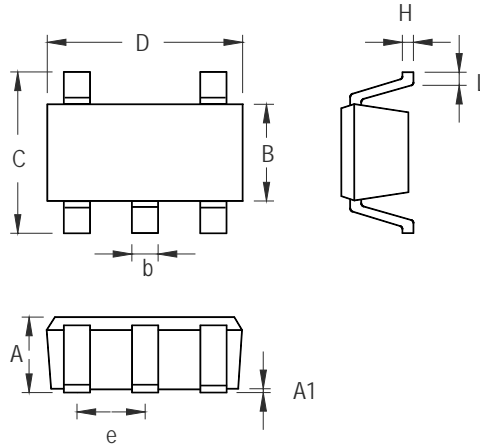

Symbol	Dimensions In Millimeters		Dimensions In Inches	
	Min	Max	Min	Max
A	0.800	1.100	0.031	0.044
A1	0.000	0.100	0.000	0.004
B	1.150	1.350	0.045	0.054
b	0.150	0.400	0.006	0.016
C	1.800	2.450	0.071	0.096
D	1.800	2.250	0.071	0.089
e	0.650		0.026	
H	0.080	0.260	0.003	0.010
L	0.210	0.460	0.008	0.018

SC-70-5 Surface Mount Package

Richtek Technology Corporation

Headquarter
 5F, No. 20, Taiyuen Street, Chupei City
 Hsinchu, Taiwan, R.O.C.
 Tel: (8863)5526789 Fax: (8863)5526611

Richtek Technology Corporation

Taipei Office (Marketing)
 8F, No. 137, Lane 235, Paochiao Road, Hsintien City
 Taipei County, Taiwan, R.O.C.
 Tel: (8862)89191466 Fax: (8862)89191465
 Email: marketing@richtek.com

Information that is provided by Richtek Technology Corporation is believed to be accurate and reliable. Richtek reserves the right to make any change in circuit design, specification or other related things if necessary without notice at any time. No third party intellectual property infringement of the applications should be guaranteed by users when integrating Richtek products into any application. No legal responsibility for any said applications is assumed by Richtek.