



# Buck-Boost DC/DC and LDO Power Management IC

The 900842 is comprised of a fully integrated, 4-switch synchronous Buck-Boost DC/DC regulator and a low noise, low dropout linear regulator (LDO).

The 900842 is supplied from a single Li-Ion battery cell, and steps up or down an input voltage range of 3.0 to 4.4 V to provide a fixed output voltage of 3.3 V. It provides two pins to monitor the status of the IC: a digital status signal, and an analog voltage proportional to the average output current.

The 900842 is housed in a 3x3 mm, Pb-free, wafer level chip scale package (WLCSP) with a 0.4 mm pitch.

## Features

- Operates from a single Li-Ion cell  $3.0\text{ V} \leq V_{IN} \leq 4.4\text{ V}$
- Fixed 3.3 V output voltage
- Uses internal MOSFETS
- 1.625 MHz PWM switching frequency
- Seamless transition between Buck and Boost modes
- Peak current limiting and output current reporting
- Uses internal compensation
- Low-power operating mode

## Applications

- Mobile internet devices
- Tablet PCs
- Netbooks

**900842**

**POWER MANAGEMENT**

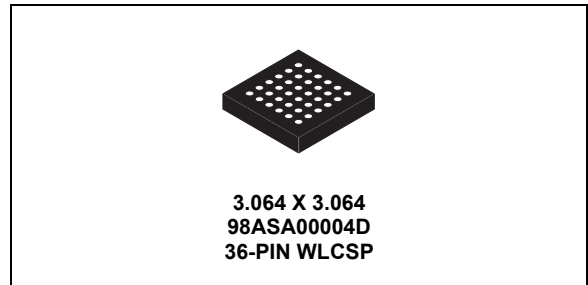

ORDERING INFORMATION		
Device	Temperature Range (T <sub>A</sub> )	Package
SCCSP900842/R2	-40 °C to 85 °C	36-PIN WLCSP

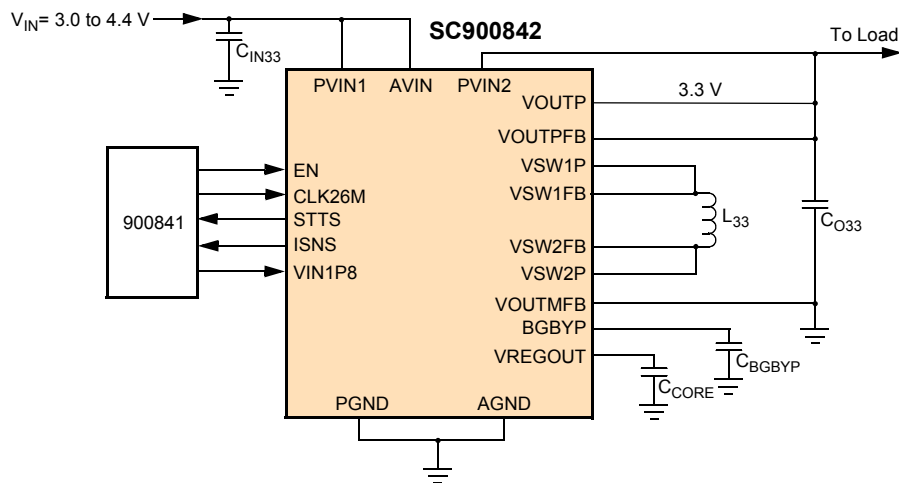

Figure 1. 900842 Simplified Application Diagram

\* This document contains certain information on a new product. Specifications and information herein are subject to change without notice.

© Freescale Semiconductor, Inc., 2010. All rights reserved.



## INTERNAL BLOCK DIAGRAM

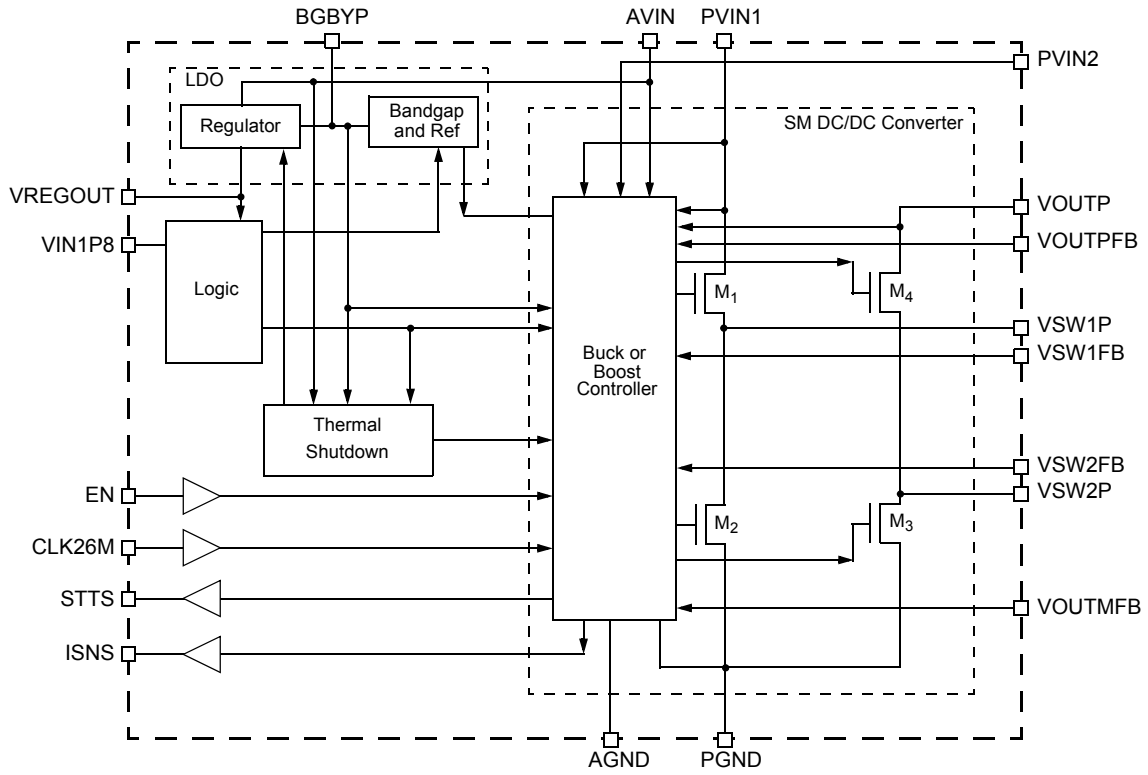

Figure 2. 900842 Internal Block Diagram

## PIN CONNECTIONS

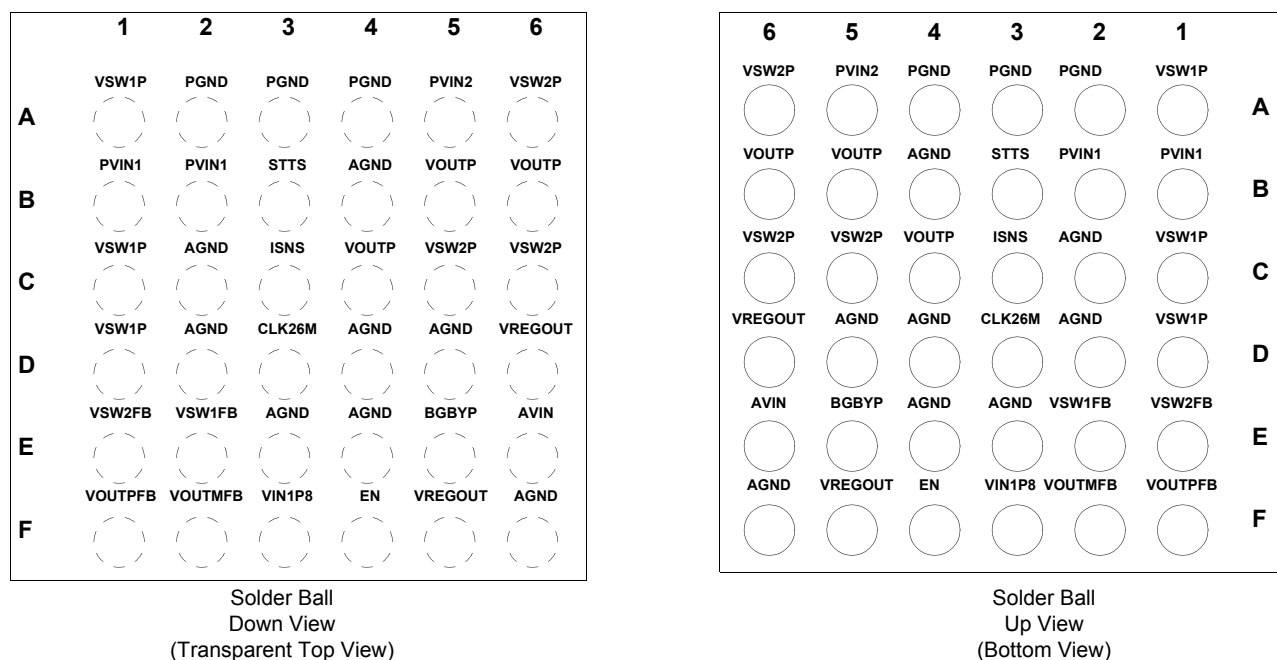

Figure 3. 900842 Pin Connections

Table 1. 900842 Pin Definitions

A functional description of each pin can be found in the Functional Pin Description section beginning on [page 10](#).

Pin Number	Name	Type	I/O	Definition	Voltage
A1	VSW1P	Analog	O	Switching Node 1	0 - 4.7 V
A2	PGND	Ground	G	Power Ground	0 V
A3	PGND	Ground	G	Power Ground	0 V
A4	PGND	Ground	G	Power Ground	0 V
A5	PVIN2	Supply	P	Power VIN	2.8 - 4.7 V
A6	VSW2P	Analog	O	Switching Node 2	0 - 4.7 V
B1	PVIN1	Supply	P	Power VIN	2.8 - 4.7 V
B2	PVIN1	Supply	P	Power VIN	2.8 - 4.7 V
B3	STTS	Digital	O	Power Good Signal - Active Low	1.8 V
B4	AGND	Ground	G	Analog Ground	0 V
B5	VOUTP	Analog	O	Output Voltage	3.3 V
B6	VOUTP	Analog	O	Output Voltage	3.3 V
C1	VSW1P	Analog	O	Switching Node 1	0 - 4.7 V
C2	AGND	Ground	G	Analog Ground	0 V
C3	ISNS	Analog	O	Current Sense Signal	0 - 4.7 V
C4	VOUTP	Analog	O	Output Voltage	3.3 V
C5	VSW2P	Analog	O	Switching Node 2	0 - 4.7 V

**Table 1. 900842 Pin Definitions**

A functional description of each pin can be found in the Functional Pin Description section beginning on [page 10](#).

Pin Number	Name	Type	I/O	Definition	Voltage
C6	VSW2P	Analog	O	Switching Node 2	0 - 4.7 V
D1	VSW1P	Analog	O	Switching Node 1	0 - 4.7 V
D2	AGND	Ground	G	Analog Ground	0 V
D3	CLK26M	Digital	I	26 MHz Clock input	1.8 V
D4	AGND	Ground	G	Analog Ground	0 V
D5	AGND	Ground	G	Analog Ground	0 V
D6	VREGOUT	Analog	O	LDO Output	2.775 V
E1	VSW2FB	Analog	I	Switching Node 2 Feedback	0 - 4.7 V
E2	VSW1FB	Analog	I	Switching Node 1 Feedback	0 - 4.7 V
E3	AGND	Ground	G	Analog Ground	0 V
E4	AGND	Ground	G	Analog Ground	0 V
E5	BGBYP	Analog	O	Reference Bypass Cap	1.2 V
E6	AVIN	Supply	P	Analog VIN	2.8 - 4.7 V
F1	VOUFPFB	Analog	I	Output Voltage Differential Feedback, Positive	3.3 V
F2	VOU MF B	Analog	I	Output Voltage Differential Feedback, Reference	0 V
F3	VIN1P8	Supply	P	1.8 V Supply	1.8 V
F4	EN	Digital	I	Enable Signal	1.2 V / 1.8 V
F5	VREGOUT	Analog	O	LDO Output	2.775 V
F6	AGND	Ground	G	Analog Ground	0 V

## ELECTRICAL CHARACTERISTICS

## MAXIMUM RATINGS

**Table 2. Absolute Maximum Ratings**

All voltages are with respect to ground unless otherwise noted. Exceeding these ratings may cause a malfunction or permanent damage to the device.

Pin / Parameter	Min	Max	Unit
<b>Maximum Voltage</b>			V
PVIN1, PVIN2, VSW1P, VSW2P, VOUTP, VSW1FB, and VSW2FB	-0.3	+7.5	
AVIN, VOUTPFB, STTS, ISNS	-0.3	+5.5	
VREGOUT	-0.3	+3.1	
BGBYP, EN, VIN1P8, and CLK26M	-0.3	+2.5	
All other pins	-0.3	+2.5	
<b>ESD Voltage, All Pins<sup>(1)</sup></b>			
Human Body Model	-2	+2	kV
Machine Model	-200	+200	V
Charge Device Model	-500	+500	V

## THERMAL RATINGS

Ambient Operating Temperature	-40	+85	°C
Operating Junction Temperature	-40	+150	°C
Storage Temperature	-65	+150	°C
Peak Package Reflow Temperature <sup>(2),(3)</sup>		+260	°C
Maximum Power Dissipation ( $T_A = 25\text{ °C}$ ), $P_D$ <sup>(4)</sup>		940	mW

## THERMAL RESISTANCE

Parameter	Symbol	Value	Unit
Thermal Resistance			
Junction to Ambient (Single Layer Board)	$R_{\theta JA(1)}$	144	°C/W
Junction to Ambient (Four Layer Board)	$R_{\theta JA(4)}$	69	°C/W
Junction to Board	$R_{\theta JB}$	27	°C/W

## Notes:

- ESD testing is performed in accordance with the Human Body Model (HBM) (CZAP = 100 pF, RZAP = 1500  $\Omega$ ), the Machine Model (MM) (CZAP = 200 pF, RZAP = 0  $\Omega$ ), and the Charge Device Model (CDM), Robotic (CZAP = 4.0 pF).
- Pin soldering temperature limit is for 10 seconds maximum duration. Not designed for immersion soldering. Exceeding these limits may cause malfunction or permanent damage to the device.
- Freescale's Package Reflow capability meets Pb-free requirements for JEDEC standard J-STD-020C for Peak Package Reflow Temperature and Moisture Sensitivity Levels (MSL).
- For  $T_J=150\text{ °C}$ ,  $T_A=85\text{ °C}$  and  $R_{\theta JA}=69\text{ °C/W}$ , application with a 4-layer board.

**ELECTRICAL CHARACTERISTICS**

**Table 3. System Electrical Characteristics**

T<sub>A</sub> = -40 °C to 85 °C, unless otherwise noted. Typical values are characterized at VPWR = 3.6 V and 25°C

Parameter	Symbol	Min	Typ	Max	Unit
<b>GENERAL</b>					
Typical Input Voltage Range	V <sub>IN</sub>	3.0	3.6	4.4	V
Extended Input Voltage Range <sup>(5)</sup>	V <sub>IN</sub>	2.8	3.6	4.7	V
Leakage Current EN=0	I <sub>LEAK</sub>	-	10	-	μA
Bandgap Voltage <sup>(6)</sup>	V <sub>BGBYP</sub>	-	1.2	-	V
<b>BUCK/BOOST CONVERTER</b>					
Output Voltage	V <sub>33</sub>	-	3.3	-	V
Output Voltage Accuracy		-4.0	-	5.0	%
Continuous Output Load Current <sup>(7)</sup>	I <sub>33</sub>	0	0.7	1.4	A
Short Circuit Output Current Limit <sup>(8)</sup> PVIN1 = 3.6 V	I <sub>LIM33</sub>	-	1.5	-	A
Transient Load Change <sup>(9)</sup>	ΔI <sub>33</sub>	-	-	0.5	A
Soft Start Time EN=1.8 V to STTS=0	t <sub>SS33</sub>	-	-	700	μs
Turn Off Time EN=0 to STTS=1	t <sub>33OFF</sub>	-	-	1.0	ms
Switching Frequency	f <sub>SW</sub>	-	1.625	-	MHz
EN Input Voltage - Normal Mode			1.8		V
EN Input Voltage - Low Power Mode			1.2		V
<b>LINEAR REGULATOR</b>					
Output Voltage	V <sub>REGOUT</sub>	-	2.775	-	V
Output Voltage Accuracy	V <sub>REGOUT</sub>	-5.0	-	5.0	%
Load Current	I <sub>L</sub>	0	-	100	mA
Maximum Short-circuit Output Current V <sub>IN</sub> >V <sub>IN-MIN</sub> , Short-circuit V <sub>REGOUT</sub>	I <sub>LSC</sub>	100	-	200	mA
Load Regulation 1.0 mA < I <sub>L</sub> < 100 mA		-1.0	-	0.5	mV/mA
Line Regulation 3.0 V < V <sub>IN</sub> < 4.4 V		-25	-	25	mV

Notes

- The IC will operate below 3.0 V, but will not meet the specifications.
- No external DC loading is allowed at the BGBYP pin.
- The maximum output current of 1.4 A is specified for V<sub>IN</sub>=3.6 V, with the IC operating in Buck mode.
- The IC has an input peak current limit in which M1 is the current sense device (Figure 2). This maximum current is different than the output current if the IC is in Boost mode
- The maximum speed of change of a transient load should be 0.1 A/μs

**Table 3. System Electrical Characteristics (continued)** $T_A = -40\text{ }^{\circ}\text{C}$  to  $85\text{ }^{\circ}\text{C}$ , unless otherwise noted. Typical values are characterized at VPWR = 3.6 V and  $25\text{ }^{\circ}\text{C}$ 

Parameter	Symbol	Min	Typ	Max	Unit
<b>EXTERNAL COMPONENTS</b>					
Output Inductor	$L_{33}$	-	1.0	-	$\mu\text{H}$
Output Inductor DCR	$L_{33\text{DCR}}$	-	-	55	$\text{m}\Omega$
Output Capacitor - Ceramic	$C_{O33}$	-	22		$\mu\text{F}$
Input Capacitor - Ceramic	$C_{IN33}$	-	10		$\mu\text{F}$
Internal Regulator Capacitor - Ceramic	$C_{\text{CORE}}$	-	1.0		$\mu\text{F}$
Bandgap Bypass Capacitor - Ceramic	$C_{\text{BGBYP}}$	-	0.1		$\mu\text{F}$

ELECTRICAL PERFORMANCE CURVES

900842 EFFICIENCY

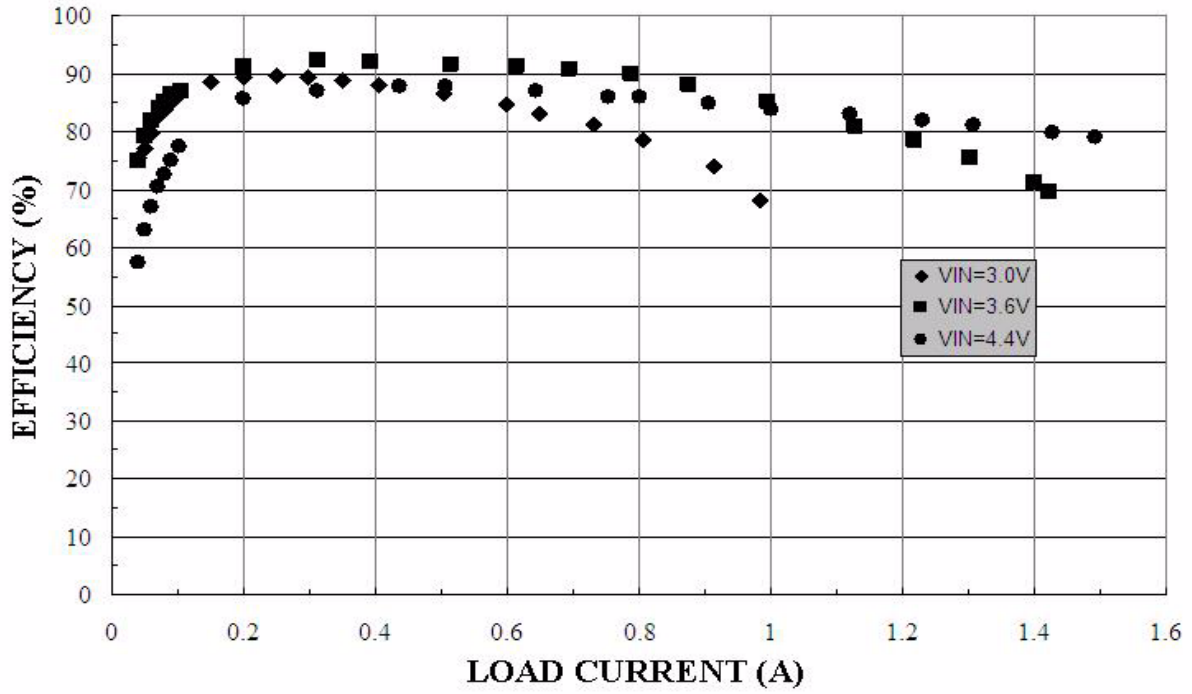

Figure 4. Switcher Efficiency vs. Output Current



## FUNCTIONAL DESCRIPTION

### INTRODUCTION

The 900842 consists of an integrated switched-mode synchronous Buck-Boost DC/DC converter and its control circuit, a linear regulator, and a bandgap voltage reference.

The 900842 is supplied from a single Lithium-Ion battery cell, and steps down or up an input voltage range of 2.8 -

4.7 V, to a fixed output voltage of 3.3 V. A high switching frequency of 1.625 MHz enables the use of small passive filter components, and improves the dynamic response of the converter.

### BUCK/BOOST CONVERTER

The integrated Buck-Boost converter is used to generate the fixed output voltage of 3.3 V. The IC operates in Buck mode when  $V_{IN}$  is greater than 3.3 V and in Boost mode otherwise.

When in Buck mode, M1 is used as a high side FET, M2 is used as a low side synchronous rectifier FET, M4 is on, and M3 is open (Figure 2). When in Boost mode, M1 is on, M2 is open, M3 is the switching FET, and M4 is the synchronous rectifier FET.

The IC transitions seamlessly between Buck and Boost mode following the variation in the input voltage,  $V_{IN}$ . The Buck-Boost converter is compensated internally.

There are 2 output pins that can be used to monitor the status of the IC:

STTS - Status output pin, active low.

STTS = 0 if the output voltage  $V_{OUTP}$  is up

STTS = 1 if the IC is under thermal shutdown, IC is in current limit, or  $V_{OUTP}$  is too low.

ISNS - Current sense pin

The ISNS pin voltage is proportional to the average output current. When  $PVIN = 3.6$  V, a typical ratio is 2.084 V/A.

### Current Limiting

A peak current limit circuit protects the converter during overload conditions. If the current through the PMOS power switch M1 exceeds the  $I_{LIM33}$  value, M1 will turn off and the converter will skip the next cycle. This forces the inductor current to be reduced to a safe value. The PMOS power switch M1 is turned on again and the cycle is repeated until the load current is reduced.

### Low Power Mode

A Low Power Mode is provided in the IC to minimize system power dissipation at low loads. In Low Power Mode, the IC operates as an LDO, with a quiescent current of 1mA.

To enter Low Power Mode, a voltage of 1.2 V must be applied to the EN pin. The Low Power Mode can only be entered after the Buck-Boost has started up in Normal Operation ( $EN = 1.8$  V).

### LOW DROPOUT LINEAR REGULATOR

The low dropout (LDO) linear regulator uses the bandgap as a reference and provides a low noise supply. The nominal regulator output voltage,  $V_{REGOUT}$ , is 2.775 V and is

designed for a steady state maximum current of 100 mA. The  $V_{REGOUT}$  voltage will decrease when the load demands currents exceeding the current limit.

## **FUNCTIONAL PIN DESCRIPTION**

### **POWER SUPPLY INPUT VOLTAGE (PVIN1)**

This is the input voltage for the Buck-Boost DC/DC converter. Input decoupling/filtering is required for proper operation.

### **POWER GROUND (PGND)**

Power Ground connection.

### **OUTPUT VOLTAGE (VOUTP)**

This is the 3.3 V output node.

### **SWITCHING NODE 1 (VSW1P)**

This output pin is the switching node when the device operates in Buck mode. The inductor is connected between this pin and the VSW2P pin.

### **SWITCHING NODE 2 (VSW2P)**

This output pin is the switching node when the device operates in Boost mode. The inductor is connected between this pin and the VSW1P pin.

### **SWITCHING NODE 1 FEEDBACK (VSW1FB)**

Feedback voltage from Switching Node 1. This pin must be directly connected to the inductor terminal.

### **SWITCHING NODE 2 FEEDBACK (VSW2FB)**

Feedback voltage from Switching Node 2. This pin must be directly connected to the inductor terminal.

### **OUTPUT VOLTAGE POSITIVE FEEDBACK (VOUTPFB)**

This input must be connected to the positive end of the output capacitor.

### **OUTPUT VOLTAGE NEGATIVE FEEDBACK (VOUTMFB)**

This input must be connected to the negative end (ground) of the output capacitor.

### **ANALOG SUPPLY INPUT VOLTAGE (AVIN)**

Supply voltage for the Buck-or-Boost Controller and LDO regulator.

### **ANALOG GROUND (AGND)**

Analog ground of the IC.

### **BOOST GATE DRIVE SUPPLY (PVIN2)**

This pin is connected to the output pin, VOUTP.

### **LDO REGULATED OUTPUT (VREGOUT)**

2.775 V LDO regulated output voltage.

### **REFERENCE BYPASS CAPACITOR (BGBYP)**

Connect a 0.1  $\mu$ F decoupling filter capacitor between this pin and GND.

### **1.8 V SUPPLY INPUT VOLTAGE (VIN1P8)**

1.8 V supply for digital sub-circuits.

### **26 MHz CLOCK INPUT (CLK26M)**

A 26 MHz clock input reference signal.

### **ENABLE (EN)**

Active high enable input signal to turn on the 3.3 V output.

- EN = 1.8 V to enter Normal Operation Mode.
- EN = 1.2 V to enter Low Power Mode.

The Low Power Mode can only be entered after the Buck-Boost has started up in Normal Operation.

### **POWER GOOD STATUS SIGNAL (STTS)**

This is an active low output signal that indicates the status of the output voltage. This signal will be high if the IC is under thermal shutdown, IC is in current limit, or  $V_{OUTP}$  is too low.

### **CURRENT SENSE SIGNAL (ISNS)**

This output pin provides an analog voltage proportional to the average output current.

## TYPICAL APPLICATIONS

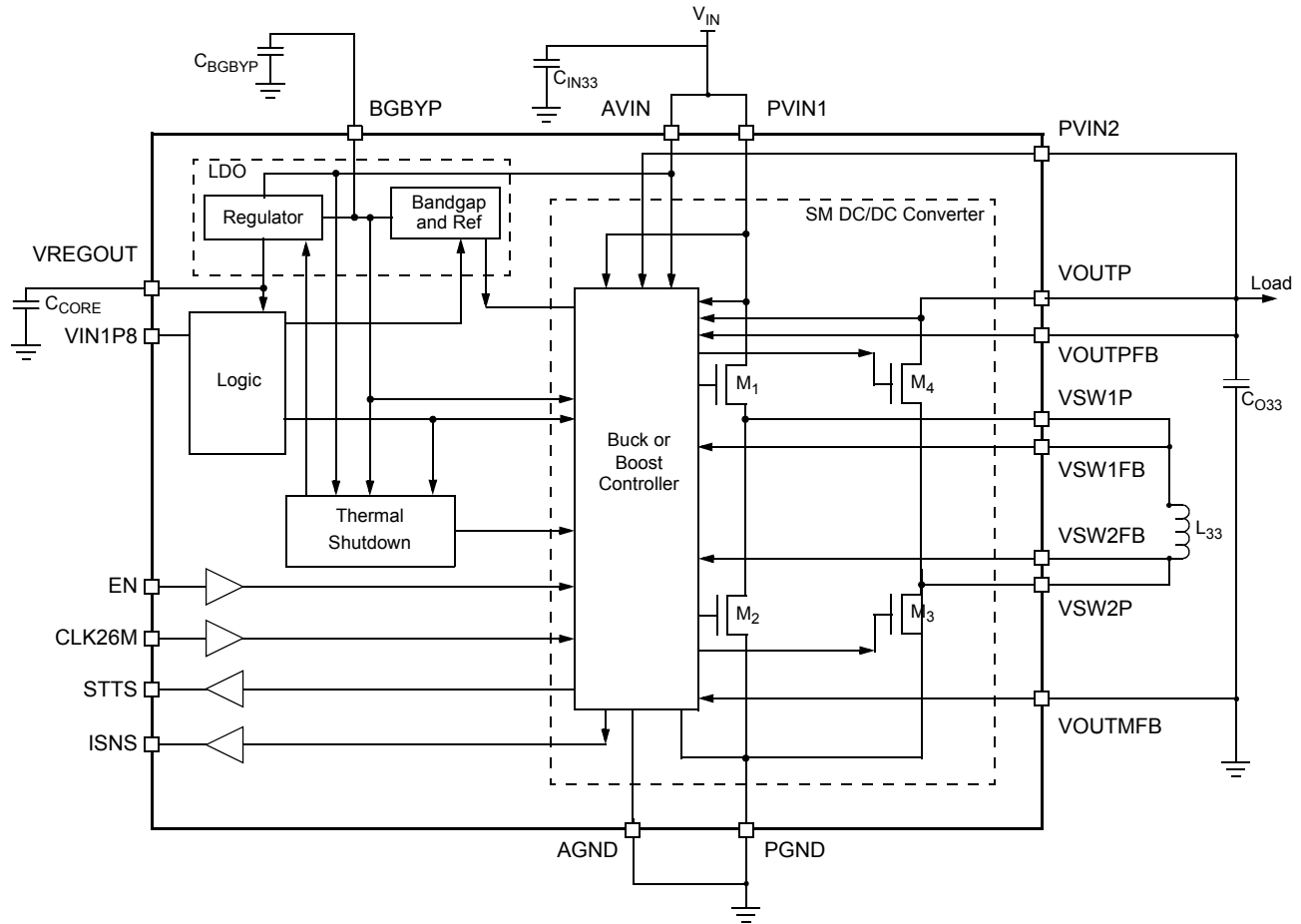

Figure 5. 900842 Typical Applications

### TYPICAL CIRCUIT

Figure 5. 900842 Typical Applications, shows the schematic for a typical application. A 1- $\mu$ H inductor with saturation current rating over 2.5 A is recommended for the SM DC/DC converter. The inductor series DC resistance (DCR) should be less than 55 mohm to achieve good efficiency and a low drop-out voltage. If a smaller inductance is used, the 900842 may become unstable under line and load transients and the transient response time may be affected. The 900842 is designed for ceramic capacitor in its input and output filters. The input filter capacitor, CIN33, reduces the voltage ripple on VIN, by providing the AC current drawn to the M1 switch during the first part of each

switching cycle. A 10  $\mu$ F ceramic capacitor should be used for CIN33 as close as possible to the PVIN1 and PGND pins of the IC. The triangular AC component of the inductor current passes through the output filter capacitor, CO33, which reduces the output voltage ripple and maintains a constant output voltage during load and line transients. A 22  $\mu$ F ceramic capacitor should be used for CO33 as close as possible to the VOUTP and PGND pins. A 100 nF ceramic capacitor should be used for CBGBYP as close as possible to the BGBYP and AGND pins. A 1.0  $\mu$ F ceramic capacitor should be used for CCORE as close as possible to the VREGOUT and AGND pins. Ceramic capacitor types such as X5R and X7R are recommended.

# PACKAGING

## PACKAGE DIMENSIONS

For the most current package revision, visit [www.freescale.com](http://www.freescale.com) and perform a keyword search using the “98A” listed below.

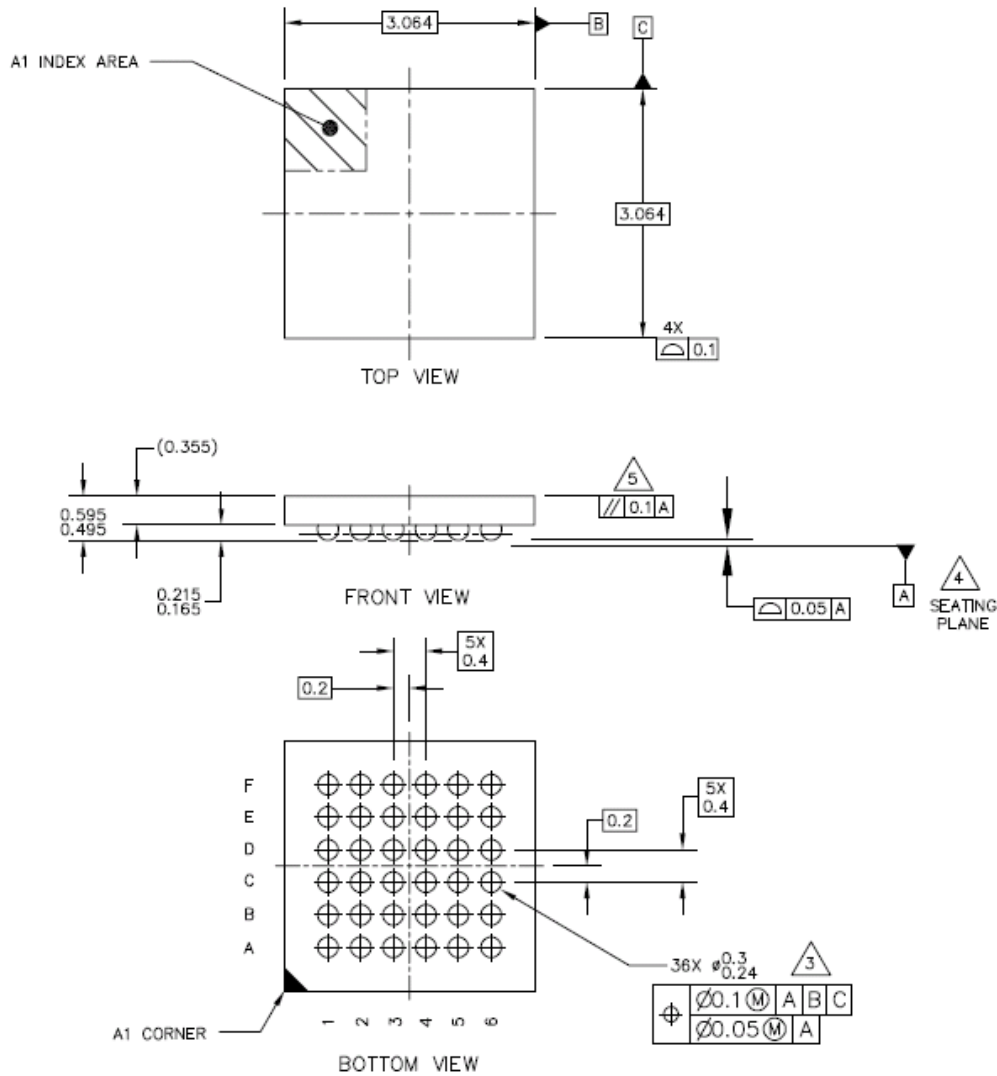

© FREESCALE SEMICONDUCTOR, INC. ALL RIGHTS RESERVED.	<b>MECHANICAL OUTLINE</b>	PRINT VERSION NOT TO SCALE	
TITLE: WAFER LEVEL CSP 36 I/O, 3.064 X 3.064 PKG, 0.4 MM PITCH	DOCUMENT NO: 98ASA00004D	REV: 0	
	CASE NUMBER: 2047-01	10 NOV 2008	
	STANDARD: NON-JEDEC		

36-PIN  
98ASA00004D  
REVISION 0

**PACKAGE DIMENSIONS (CONTINUED)**

NOTES:

1. ALL DIMENSIONS IN MILLIMETERS.
2. DIMENSIONING AND TOLERANCING PER ASME Y14.5M-1994.
3. MAXIMUM SOLDER BALL DIAMETER MEASURED PARALLEL TO DATUM A.
4. DATUM A, THE SEATING PLANE, IS DETERMINED BY THE SPHERICAL CROWNS OF THE SOLDER BALLS.
5. PARALLELISM MEASUREMENT SHALL EXCLUDE ANY EFFECT OF MARK ON TOP SURFACE OF PACKAGE.

© FREESCALE SEMICONDUCTOR, INC. ALL RIGHTS RESERVED.	<b>MECHANICAL OUTLINE</b>	PRINT VERSION NOT TO SCALE	
TITLE:           WAFER LEVEL CSP 36 I/O, 3.064 X 3.064 PKG, 0.4 MM PITCH	DOCUMENT NO: 98ASA00004D	REV: 0	
	CASE NUMBER: 2047-01	10 NOV 2008	
	STANDARD: NON-JEDEC		

36-PIN  
 98ASA00004D  
 REVISION 0

## REVISION HISTORY

REVISION	DATE	DESCRIPTION OF CHANGES
1.0	3/2010	<ul style="list-style-type: none"><li>• Initial Release</li></ul>
2.0	11/2010	<ul style="list-style-type: none"><li>• Corrected format and typos</li><li>• Removed Bill of Materials and Board Layout sections</li></ul>

## How to Reach Us:

### Home Page:

[www.freescale.com](http://www.freescale.com)

### Web Support:

<http://www.freescale.com/support>

### USA/Europe or Locations Not Listed:

Freescale Semiconductor, Inc.  
Technical Information Center, EL516  
2100 East Elliot Road  
Tempe, Arizona 85284  
1-800-521-6274 or +1-480-768-2130  
[www.freescale.com/support](http://www.freescale.com/support)

### Europe, Middle East, and Africa:

Freescale Halbleiter Deutschland GmbH  
Technical Information Center  
Schatzbogen 7  
81829 Muenchen, Germany  
+44 1296 380 456 (English)  
+46 8 52200080 (English)  
+49 89 92103 559 (German)  
+33 1 69 35 48 48 (French)  
[www.freescale.com/support](http://www.freescale.com/support)

### Japan:

Freescale Semiconductor Japan Ltd.  
Headquarters  
ARCO Tower 15F  
1-8-1, Shimo-Meguro, Meguro-ku,  
Tokyo 153-0064  
Japan  
0120 191014 or +81 3 5437 9125  
[support.japan@freescale.com](mailto:support.japan@freescale.com)

### Asia/Pacific:

Freescale Semiconductor China Ltd.  
Exchange Building 23F  
No. 118 Jianguo Road  
Chaoyang District  
Beijing 100022  
China  
+86 10 5879 8000  
[support.asia@freescale.com](mailto:support.asia@freescale.com)

### For Literature Requests Only:

Freescale Semiconductor Literature Distribution Center  
P.O. Box 5405  
Denver, Colorado 80217  
1-800-441-2447 or +1-303-675-2140  
Fax: +1-303-675-2150  
[LDCForFreescaleSemiconductor@hibbertgroup.com](mailto:LDCForFreescaleSemiconductor@hibbertgroup.com)

Information in this document is provided solely to enable system and software implementers to use Freescale Semiconductor products. There are no express or implied copyright licenses granted hereunder to design or fabricate any integrated circuits or integrated circuits based on the information in this document.

Freescale Semiconductor reserves the right to make changes without further notice to any products herein. Freescale Semiconductor makes no warranty, representation or guarantee regarding the suitability of its products for any particular purpose, nor does Freescale Semiconductor assume any liability arising out of the application or use of any product or circuit, and specifically disclaims any and all liability, including without limitation consequential or incidental damages. "Typical" parameters that may be provided in Freescale Semiconductor data sheets and/or specifications can and do vary in different applications and actual performance may vary over time. All operating parameters, including "Typicals", must be validated for each customer application by customer's technical experts. Freescale Semiconductor does not convey any license under its patent rights nor the rights of others. Freescale Semiconductor products are not designed, intended, or authorized for use as components in systems intended for surgical implant into the body, or other applications intended to support or sustain life, or for any other application in which the failure of the Freescale Semiconductor product could create a situation where personal injury or death may occur. Should Buyer purchase or use Freescale Semiconductor products for any such unintended or unauthorized application, Buyer shall indemnify and hold Freescale Semiconductor and its officers, employees, subsidiaries, affiliates, and distributors harmless against all claims, costs, damages, and expenses, and reasonable attorney fees arising out of, directly or indirectly, any claim of personal injury or death associated with such unintended or unauthorized use, even if such claim alleges that Freescale Semiconductor was negligent regarding the design or manufacture of the part.



Freescale™ and the Freescale logo are trademarks of Freescale Semiconductor, Inc. All other product or service names are the property of their respective owners.

© Freescale Semiconductor, Inc. 2010. All rights reserved.

SC900842  
Rev. 2.0  
11/2010