

## FAN4146 — Ground Fault Interrupter

### Features

- For Two-Wire ALCI and RCD Applications
- Precision Sense Amplifier and Bandgap Reference
- Built-in AC Rectifier
- Direct DC Coupled to Sense Coil
- Built-in Noise Filter
- Low-Voltage SCR Disable
- SCR Gate Driver
- Adjustable Sensitivity
- Minimum External Components
- Meets UL 943B Requirements
- Ideal for 120V or 220V Systems
- Space-Saving SuperSOT™ 6-Pin Package

### Applications

- Personal Care Products
- Two-Wire Electrical Outlets, Circuit Breakers, and Power Cords Requiring GFI Safety Features
- ALCI and RCCB Circuits

### Description

The FAN4146 is a low-power controller for AC outlet Appliance Leakage Circuit Interrupters (ALCI) and two-wire Residual Current Devices (RCD). The FAN4146 detects hazardous grounding conditions and open circuits the line before a harmful shock occurs.

Internally, the FAN4146 contains a diode rectifier, precision bandgap 12V shunt regulator, precision low  $V_{OS}$  offset-sense amplifier, time delay noise filter, window-detection comparators, and a SCR driver. With the addition of a minimum number of external components, the FAN4146 detects and protects against a hot-wire-to-ground fault. The minimum number of components and the small SuperSOT™ package allow for a small-form-factor, low-cost application solution.

The FAN4146 circuitry has a built-in rectifier and shunt regulator that operates with a low quiescent current. This allows for a high-value, low-wattage-series supply resistor. The internal temperature compensated shunt regulator, sense amplifier, and bias circuitry provide for precision ground-fault detection. The low  $V_{OS}$  offset-sense amplifier allows direct coupling of the sense coil to the amplifier's feedback signal. This eliminates the large 50/60Hz AC-coupling capacitor. The internal delay filter rejects high-frequency noise spikes common with inductive loads. This decreases false nuisance tripping. The internal SCR driver is temperature compensated and designed to satisfy the current requirements for a wide selection of external SCRs.

The minimum number of external components and the 6-pin SuperSOT™ package enable for a low-cost, compact design and layout. The FAN4146ESX is an enhanced temperature range device.

### Ordering Information

Part Number	Operating Temperature Range	Package	Packing Method
FAN4146SX	0°C to +70°C	6-Lead SUPERSOT6, JEDEC MO-193, 1.6mm	Tape and Reel
FAN4146ESX	-25°C to +80°C	6-Lead SUPERSOT6, JEDEC MO-193, 1.6mm	Tape and Reel

## Typical Applications

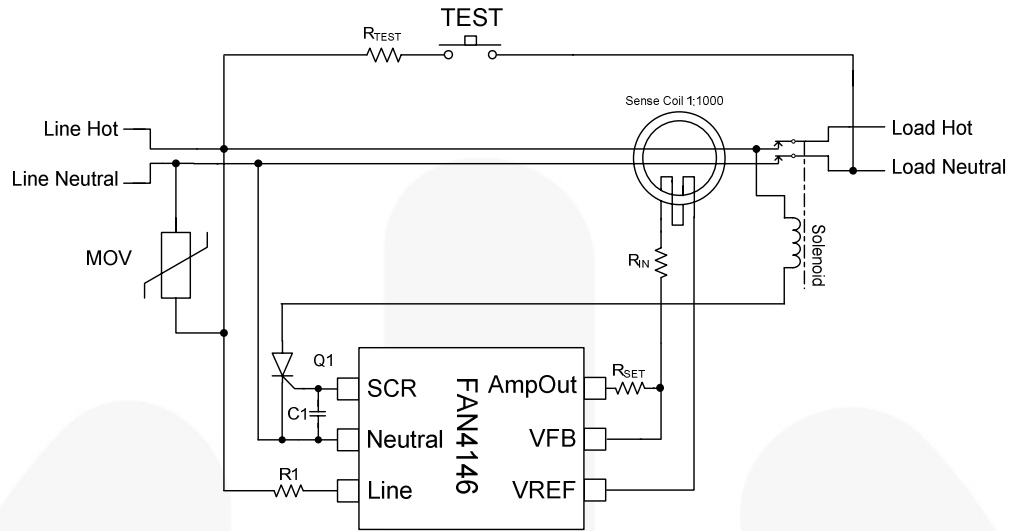

Figure 1. 120/220V<sub>AC</sub> LCI Application<sup>(2)</sup>

### Typical Values

R1: 91K $\Omega$  (Wattage Determined by Maximum V<sub>AC</sub>)      R<sub>IN</sub>: 470 $\Omega$   
 R<sub>TEST</sub>: 15K $\Omega$       C1: 22nF  
 R<sub>SET</sub>: 511K $\Omega$ <sup>(1)</sup>

#### Note:

1. Value depends on sense-coil characteristics and application (value chosen for 5mA trip threshold).
2. Contact Fairchild for best application practices for nuisance tripping rejection.

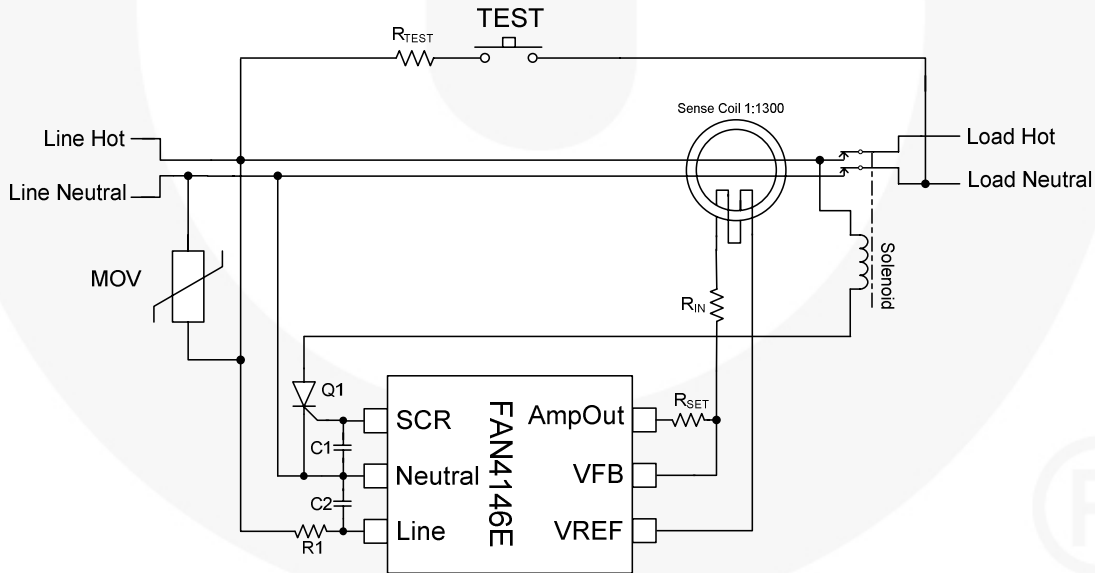

Figure 2. 220V<sub>AC</sub> RCD Application<sup>(4)</sup>

### Typical Values

R1: 174K $\Omega$  (Wattage Determined by Maximum V<sub>AC</sub>)      R<sub>SET</sub>: 324K $\Omega$ <sup>(3)</sup>      C1: 22nF  
 R<sub>TEST</sub>: 15K $\Omega$       R<sub>IN</sub>: 470 $\Omega$       C2: 10nF

#### Note:

3. Value depends on sense-coil characteristics and application (value chosen for 10mA trip threshold).
4. Contact Fairchild for best application practices for nuisance tripping rejection.

### Block Diagram

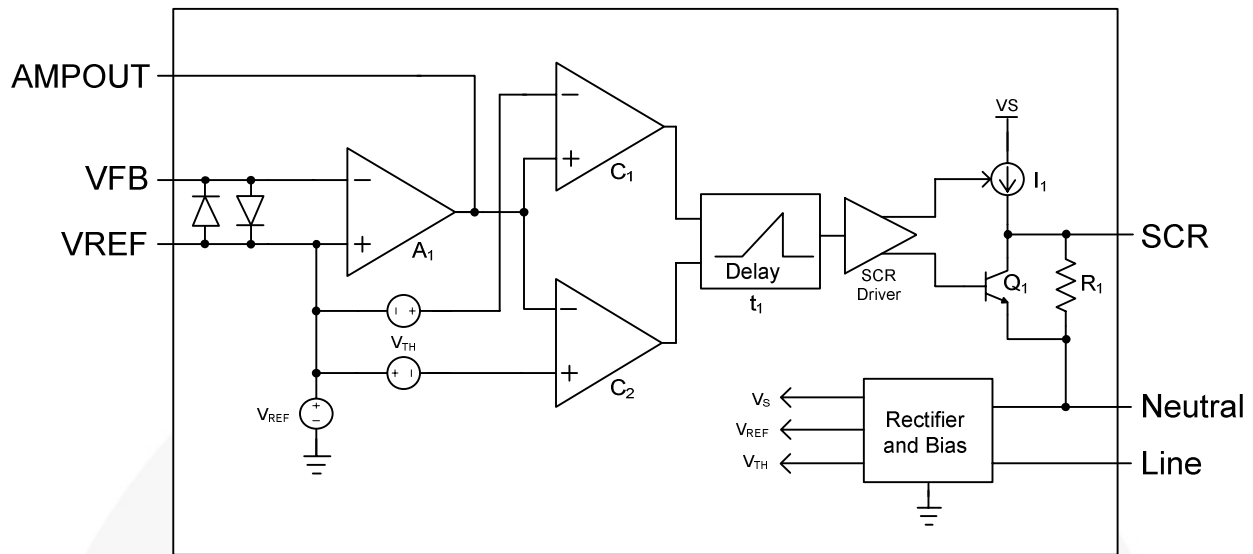

Figure 3. Block Diagram

### Pin Configuration



Figure 4. Pin Configuration

### Pin Definitions

Pin #	Name	Description
1	SCR	Gate drive for external SCR
2	Neutral	Supply input for FAN4146 circuitry
3	Line	Supply input for FAN4146 circuitry
4	VREF	Non-inverting input for current-sense amplifier
5	VFB	Inverting input for current-sense amplifier
6	AmpOut	External resistor connected to VFB sets the $I_{\text{fault}}$ sensitivity threshold

## Absolute Maximum Ratings

Stresses exceeding the absolute maximum ratings may damage the device. The device may not function or be operable above the recommended operating conditions and stressing the parts to these levels is not recommended. In addition, extended exposure to stresses above the recommended operating conditions may affect device reliability. The absolute maximum ratings are stress ratings only.

Symbol	Parameter	Condition	Min.	Max.	Unit
$I_{CC}$	Supply Current	Continuous Current, Line to Neutral		15	mA
$V_{CC}$	Supply Voltage		-1.5	16.0	V
		All other pins	-0.8	15.0	V
$T_{STG}$	Storage Temperature Range		-65	+150	°C
ESD	Electrostatic Discharge Capability	Human Body Model, JESD22-A114		2500	V
		Charged Device Model, JESD22-C101		1000	
		Machine Model, JESD22-A115		200	

## DC Electrical Characteristics

Unless otherwise specified,  $T_A=25^\circ\text{C}$ ,  $I_{shunt}=1\text{mA}$ .

Symbol	Parameter	Conditions	Min.	Typ.	Max.	Units
$V_{REG}$	Power Supply Shunt Regulator Voltage	Line to Neutral	12.2	12.7	13.2	V
		Line to Neutral, $I_{shunt}=-2\text{mA}$	-0.9	-0.7		
$I_Q$	Quiescent Current	Line to Neutral=10V	350	400	450	$\mu\text{A}$
$V_{REF}$	Reference Voltage	$V_{REF}$ to Neutral	5.8	6.0	6.2	V
$V_{TH}$	Trip Threshold	AmpOut to $V_{REF}$	3.4	3.5	3.6	V
$V_{OS}$	Amplifier Offset	$R_{SET}=511\text{K}\Omega$ , $R_{IN}=500\Omega$	-450	0	450	$\mu\text{V}$
$I_{OS}$	Amplifier Input Offset <sup>(5)</sup>	Design Value	-50	0	50	nA
G	Amplifier DC Gain <sup>(5)</sup>	Design Value		100		dB
$f_{GBW}$	Amplifier Gain Bandwidth <sup>(5)</sup>	Design Value		1.5		MHz
$V_{SW+}$	Amplifier Positive Voltage Swing	AmpOut to $V_{REF}$ , $I_{FAULT}=10\mu\text{A}$	4.0			V
$V_{SW-}$	Amplifier Negative Voltage Swing	$V_{REF}$ to AmpOut, $I_{FAULT}=-10\mu\text{A}$	4.0			V
$I_{SINK}$	Amplifier Current Sink	AmpOut= $V_{REF} + 3\text{V}$ , $V_{FB}=V_{REF} + 100\text{mV}$	400			$\mu\text{A}$
$I_{SRL}$	Amplifier Current Source	AmpOut= $V_{REF} - 3\text{V}$ , $V_{FB}=V_{REF} - 100\text{mV}$	400			$\mu\text{A}$
$t_d$	Delay Filter	Delay from $C_1$ Trip to SCR, LOW to HIGH	0.75	1.00	1.25	ms
$R_{OUT}$	SCR Output Resistance	SCR to Neutral=250mV, AmpOut= $V_{REF}$		0.5	1.0	$\text{K}\Omega$
$V_{OUT}$	SCR Output Voltage	SCR to Neutral, AmpOut= $V_{REF}$		1	10	mV
		SCR to Neutral, AmpOut= $V_{REF} + 4\text{V}$	2.5			V
$I_{OUT}$	SCR Output Current	SCR to Neutral=1V AmpOut= $V_{REF} + 4\text{V}$	350	500		$\mu\text{A}$

### Note:

5. Guaranteed by design; not tested in production.

## Functional Description

Refer to Figure 1 and Figure 3.

The FAN4146 is a two-wire GFCI controller for AC ground-fault-circuit interrupters. The internal rectifier circuit is biased by the AC line during the positive half cycle of the AC line voltage. The internal 12V shunt regulator uses a precision temperature-compensated bandgap reference. The combination of precision reference circuitry and precision sense amplifier provides for an accurate ground-fault tolerance. This allows for selection of external components with wider and lower-cost parameter variation. Due to the low quiescent current, a high value external series resistor ( $R_1$ ) can be used which reduces the maximum power wattage required for this resistor. The 12V shunt regulator generates the reference voltage  $V_{REF}$  for the sense amplifier's ( $A_1$ ) non-inverting input (AC ground reference) and supplies the bias for the delay timer ( $t_1$ ), comparators ( $C_1$  &  $C_2$ ), and the SCR driver.

The secondary winding of the sense transformer is directly DC coupled to the inverting input of the sense amplifier at pin 5 ( $V_{FB}$ ). The  $R_{SET}$  resistor converts the sense transformer's secondary current to a voltage at pin 6 (AmpOut). This voltage is compared to the internal window comparator ( $C_1$  &  $C_2$ ) and, when the AmpOut voltage exceeds the  $\pm V_{TH}$  threshold voltage, the window comparator triggers the internal delay timer. The output of the window comparator must stay HIGH for the duration of the  $t_1$  timer. If the window comparator's output momentarily goes LOW, the  $t_1$  timer resets. If the window comparator's output is still HIGH at the end of the  $t_1$  pulse, the SCR driver enables the current source  $I_1$  and disables  $Q_1$ . The current source  $I_1$  then enables the external SCR, which energizes the solenoid, opens the contact switches to the load, and removes the hazardous ground fault. The window comparator allows detection of a positive or negative  $I_{FAULT}$  signal independent from the phase of the line voltage. An internal under-voltage lockout circuit disables the SCR driver if the voltage at pin 3 (LINE) is below 7.5V. This prevents the SCR from energizing the solenoid when the SCR's anode voltage is below 65V.

The sense transformer typically has a toroidal core made of laminated steel rings or solid ferrite material. The secondary of the transformer is typically 1000 turns of #40 wire wound through the toroid. The primary is typically one turn made by passing the AC hot and neutral wires through the center of the toroid. When a ground fault exists, a difference exists between the current flowing in hot and neutral wires. The primary difference current divided by the primary-to-secondary turns ratio is the current that flows through the secondary wire of the transformer.

## Calculation of $R_{SET}$ Resistor

The AmpOut signal must exceed the window comparator's  $V_{TH}$  threshold voltage for longer than the delay timer and calculated by:

$$V_{TH} = I_{FAULT} \times 1.41 \times R_{SET} \times \cos(2\pi \times (t/2P)) / N \quad (1)$$

$$R_{SET} = (V_{TH} \times N) / (1.41 \times I_{FAULT} \times \cos(\pi \times t/P)) \quad (2)$$

where:

$$V_{TH} = 3.5V$$

$$I_{FAULT} = 5mA \text{ (UL943B)}$$

$$t = 1ms \text{ (timer delay)}$$

$$P = \text{Period of the AC Line (1/60Hz)}$$

$$N = \text{Ratio of secondary to primary turns (1000:1)}$$

$$R_{SET} = 505K\Omega \text{ (511K}\Omega \text{ standard 1\% value)}$$

In practice, the transformer is non-ideal, so  $R_{SET}$  may need to be adjusted by up to 30% to obtain the desired  $I_{fault}$  trip threshold.

## Calculation of $V_{OS}$ Trip Threshold Error

Since the sense coil is directly connected to the feedback of the sense amplifier, the  $V_{OS}$  offset introduces an  $I_{fault}$  threshold error. This error can be calculated as follows:

$$\%Error = 100 \times (V_{OS} \times R_{SET}) / (R_{IN} + R_{LDC} + R_{LAC}) / V_{TH} \quad (3)$$

where:

$$V_{OS} = \begin{matrix} +/-450\mu V \text{ (worst case)} \\ +/-150\mu V \text{ (typical)} \end{matrix}$$

$$R_{SET} = 511K\Omega$$

$$R_{IN} = 470\Omega \text{ (typical value)}$$

$$R_{LDC} = 75\Omega \text{ (sense coil secondary DC resistance)}$$

$$R_{LAC} = 1.5 K\Omega \text{ (AC}_{(j\omega L)} \text{ impedance of sense coil),}$$

$$L = 4H, f = 60Hz)$$

$$V_{TH} = 3.5V$$

$$\%Error = \begin{matrix} +/- 3.2\% \text{ (worst case)} \\ +/- 1.1\% \text{ (typical)} \end{matrix}$$

## Typical Performance Characteristics

Unless otherwise specified,  $T_A=25^\circ\text{C}$  and according to Figure 1 with SCR disconnected.

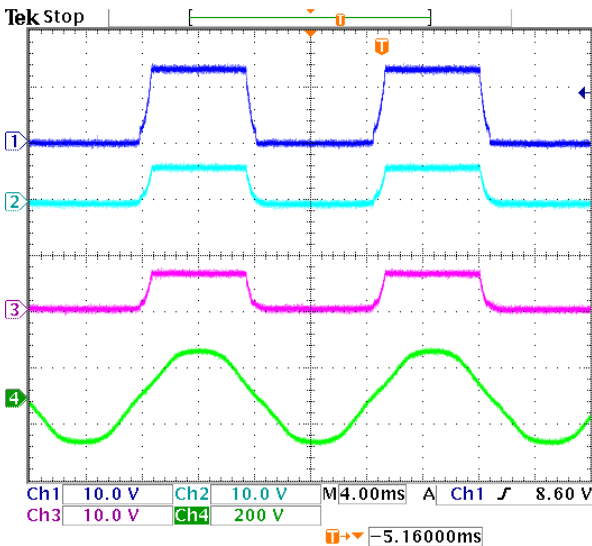

Ch1:  $V_{Line}$  (Pin 3), 10V/Div  
 Ch2: AmpOut (Pin 6), 10V/Div  
 Ch3:  $V_{REF}$  (Pin 4), 10V/Div  
 Ch4:  $V_{AC}$  Input, 200V/Div

**Figure 5. Typical Waveforms, No Ground Fault**

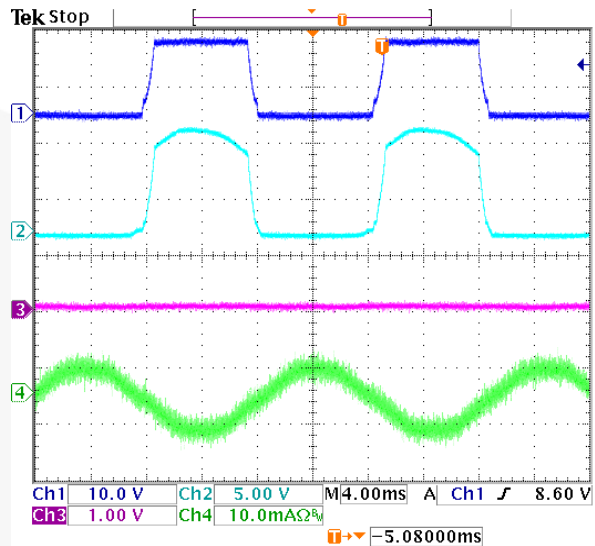

Ch1:  $V_{Line}$  (Pin 3), 10V/Div  
 Ch2: AmpOut (Pin 6), 5V/Div  
 Ch3: SCR (Pin 1), 1V/Div  
 Ch4:  $I_{FAULT}$ , 10mA/Div

**Figure 6. Typical Waveforms, 4mA Ground Fault**

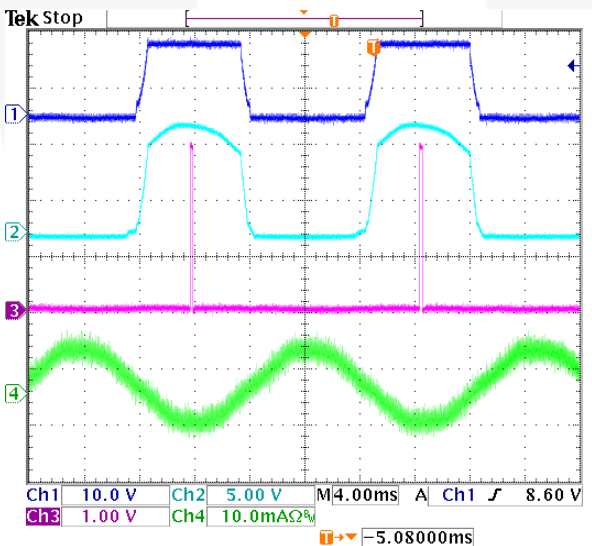

Ch1:  $V_{Line}$  (Pin 3), 10V/Div  
 Ch2: AmpOut (Pin 6), 5V/Div  
 Ch3: SCR (Pin 1), 1V/Div  
 Ch4:  $I_{FAULT}$ , 10mA/Div

**Figure 7. Typical Waveforms, 5mA Ground Fault**

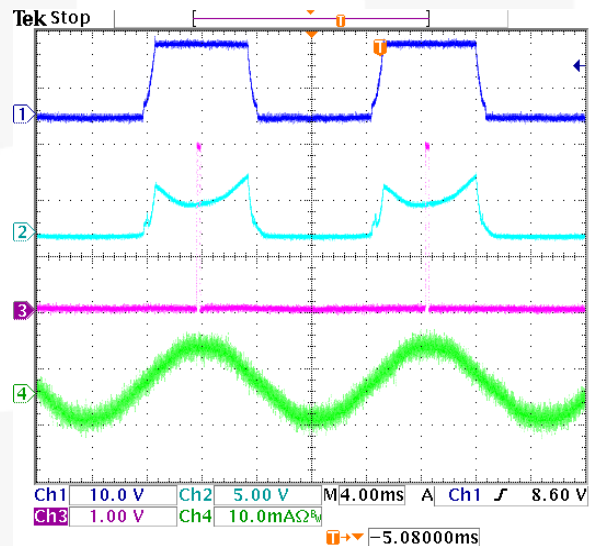

Ch1:  $V_{Line}$  (Pin 3), 10V/Div  
 Ch2: AmpOut (Pin 6), 5V/Div  
 Ch3: SCR (Pin 1), 1V/Div  
 Ch4:  $I_{FAULT}$ , 10mA/Div

**Figure 8. Typical Waveforms, 5mA Ground Fault (Line Polarity Reversal)**

*Continued on the following page...*

### Typical Performance Characteristics (Continued)

Unless otherwise specified,  $T_A=25^\circ\text{C}$  and according to Figure 1 with SCR disconnected.

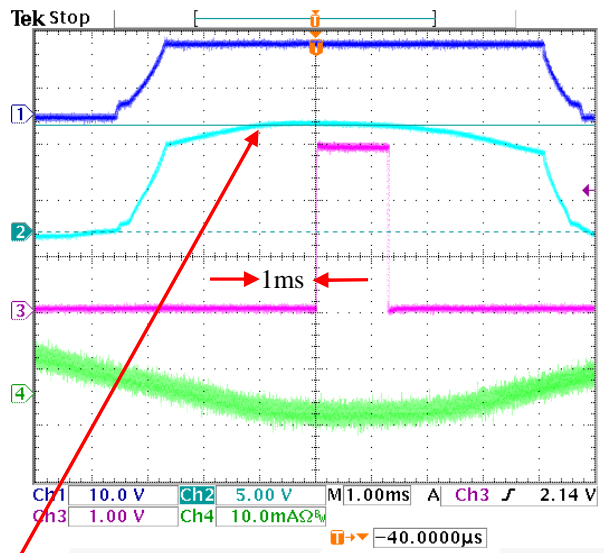

1ms after AmpOut signal reaches 9.5V, SCR is triggered.

- Ch1:  $V_{Line}$  (Pin 3), 10V/Div
- Ch2: AmpOut (Pin 6), 5V/Div
- Ch3: SCR (Pin 1), 1V/Div
- Ch4:  $I_{FAULT}$ , 10mA/Div

Figure 9. AmpOut Threshold, Internal 1ms Delay

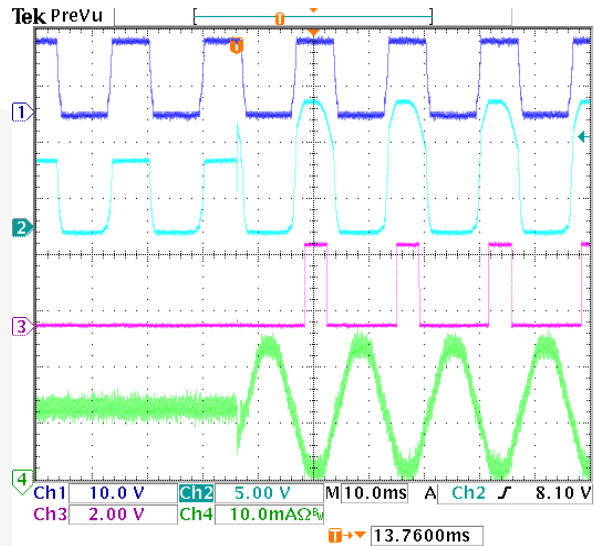

- Ch1:  $V_{Line}$  (Pin 3), 10V/Div
- Ch2: AmpOut (Pin 6), 5V/Div
- Ch3: SCR (Pin 1), 2V/Div
- Ch4:  $I_{FAULT}$ , 10mA/Div

Figure 10. 15KΩ Ground Fault

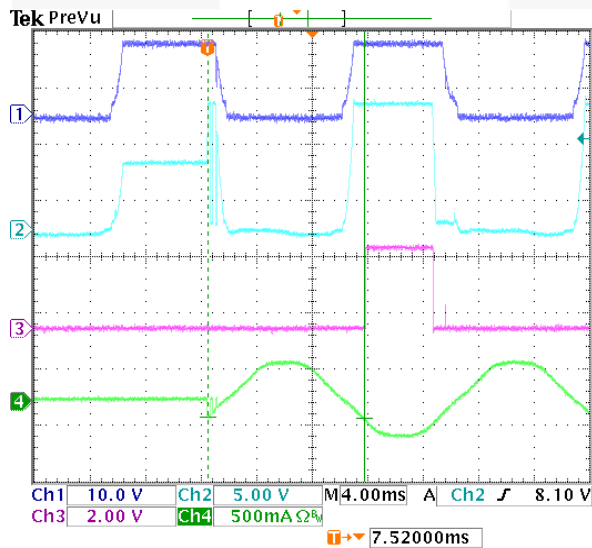

- Ch1:  $V_{Line}$  (Pin 3), 10V/Div
- Ch2: AmpOut (Pin 6), 5V/Div
- Ch3: SCR (Pin 1), 2V/Div
- Ch4:  $I_{FAULT}$ , 500mA/Div

Figure 11. 500Ω Ground Fault<sup>(6,7)</sup>

**Note:**

- 6. Maximum trip time ~12ms.
- 7. Fault occurs at the end of the positive AC cycle.



Typical Temperature Characteristics (FAN4146E)

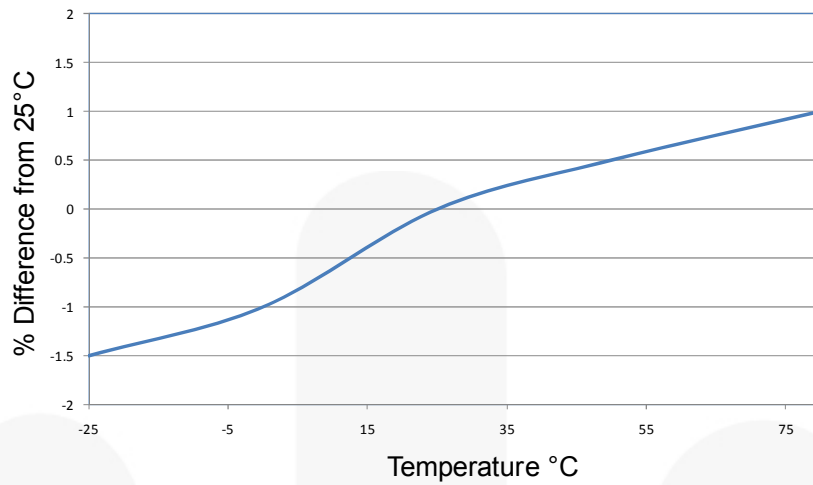

Figure 12. V<sub>Threshold</sub> (V<sub>TH</sub>) vs. Temperature

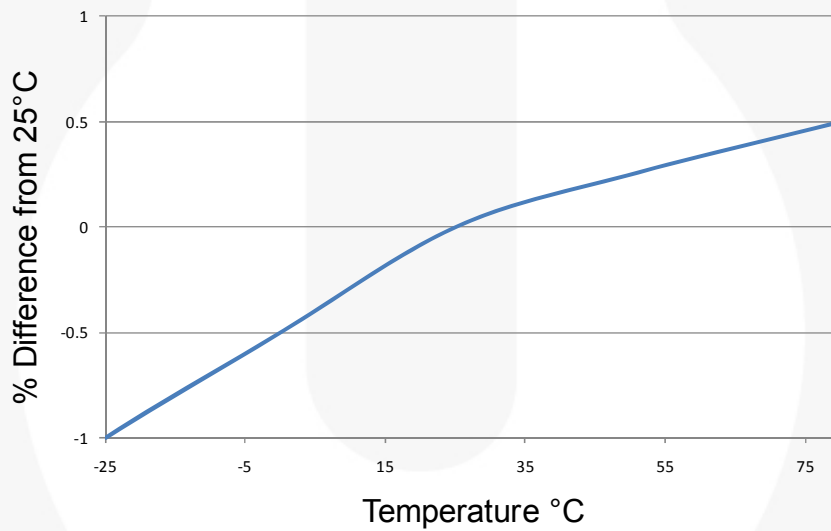

Figure 13. V<sub>Reference</sub> (V<sub>REF</sub>) vs. Temperature

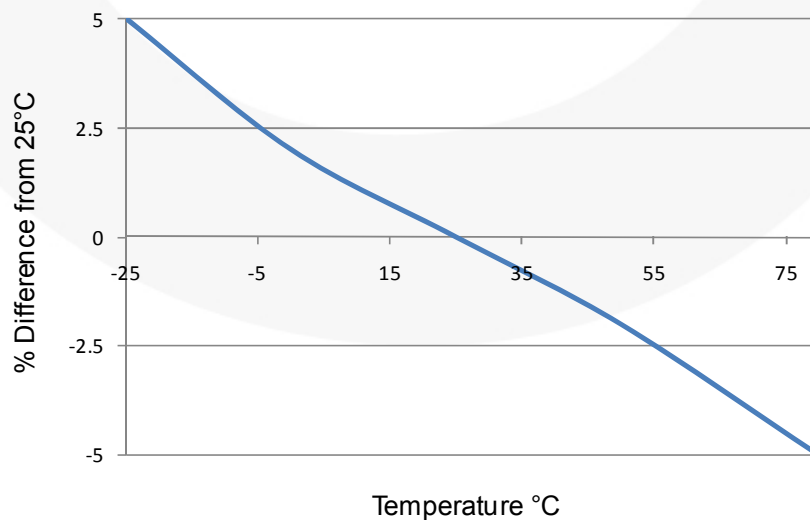

Figure 14. SCR Output Current (I<sub>OUT</sub>) vs. Temperature



Physical Dimensions

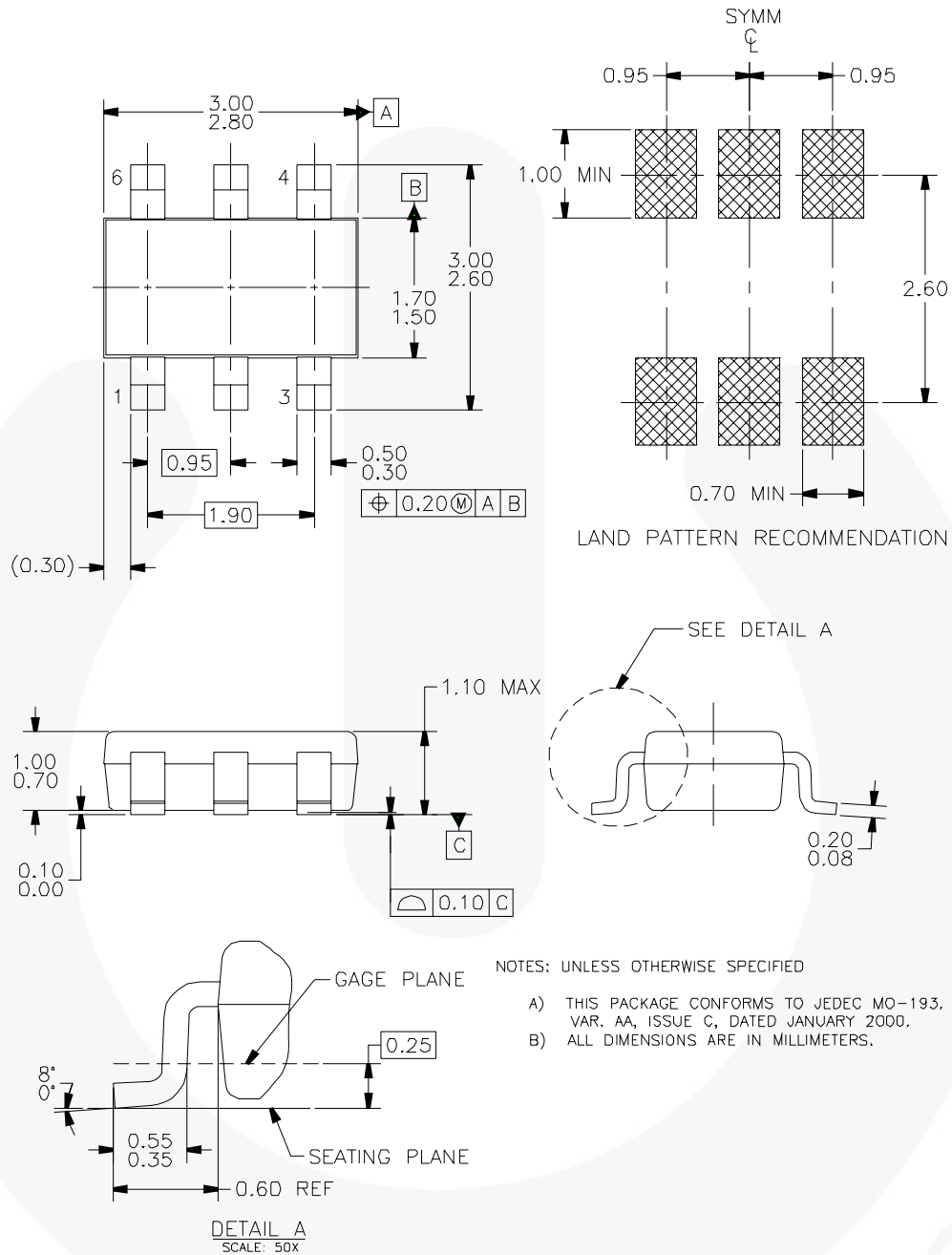

Figure 15. 6-Lead SUPERSOT6, JEDEC MO-193, 1.6mm Wide

Package drawings are provided as a service to customers considering Fairchild components. Drawings may change in any manner without notice. Please note the revision and/or date on the drawing and contact a Fairchild Semiconductor representative to verify or obtain the most recent revision. Package specifications do not expand the terms of Fairchild's worldwide terms and conditions, specifically the warranty therein, which covers Fairchild products.

Always visit Fairchild Semiconductor's online packaging area for the most recent package drawings:  
<http://www.fairchildsemi.com/packaging/>.



**TRADEMARKS**

The following includes registered and unregistered trademarks and service marks, owned by Fairchild Semiconductor and/or its global subsidiaries, and is not intended to be an exhaustive list of all such trademarks.

AccuPower™  
Auto-SPM™  
Build it Now™  
CorePLUS™  
CorePOWER™  
CROSSVOLT™  
CTL™  
Current Transfer Logic™  
DEUXPEED®  
Dual Cool™  
EcoSPARK®  
EfficientMax™  
ESBCT™  
**F**®  
Fairchild®  
Fairchild Semiconductor®  
FACT Quiet Series™  
FACT®  
FAST®  
FastvCore™  
FETBench™  
FlashWriter®  
FPST™

F-PFS™  
FRFET®  
Global Power Resource™  
Green FPST™  
Green FPST™ e-Series™  
Gmax™  
GTO™  
IntelliMAX™  
ISOPLANAR™  
MegaBuck™  
MICROCOUPLER™  
MicroFET™  
MicroPak™  
MicroPak2™  
MillerDrive™  
MotionMax™  
Motion-SPM™  
OptoHIT™  
OPTOLOGIC®  
OPTOPLANAR®  
 PDP SPM™

Power-SPM™  
PowerTrench®  
PowerXS™  
Programmable Active Droop™  
QFET®  
QS™  
Quiet Series™  
RapidConfigure™  
™  
Saving our world, 1mW/W/kW at a time™  
SignalWise™  
SmartMax™  
SMART START™  
SPM®  
STEALTH™  
SuperFET™  
SuperSOT™.3  
SuperSOT™.8  
SuperSOT™.8  
SupreMOS®  
SyncFET™  
Sync-Lock™

**SYSTEM GENERAL**®  
The Power Franchise®  
**the power franchise**  
QS™  
TinyBoost™  
TinyBuck™  
TinyCalc™  
TinyLogic®  
TINYOPTO™  
TinyPower™  
TinyPWM™  
TinyWire™  
TriFault Detect™  
TRUECURRENT™  
µSerDes™  
 SerDes™  
UHC®  
Ultra FRFET™  
UniFET™  
VCX™  
VisualMax™  
XS™

\* Trademarks of System General Corporation, used under license by Fairchild Semiconductor.

**DISCLAIMER**

FAIRCHILD SEMICONDUCTOR RESERVES THE RIGHT TO MAKE CHANGES WITHOUT FURTHER NOTICE TO ANY PRODUCTS HEREIN TO IMPROVE RELIABILITY, FUNCTION, OR DESIGN. FAIRCHILD DOES NOT ASSUME ANY LIABILITY ARISING OUT OF THE APPLICATION OR USE OF ANY PRODUCT OR CIRCUIT DESCRIBED HEREIN, NEITHER DOES IT CONVEY ANY LICENSE UNDER ITS PATENT RIGHTS, NOR THE RIGHTS OF OTHERS. THESE SPECIFICATIONS DO NOT EXPAND THE TERMS OF FAIRCHILD'S WORLDWIDE TERMS AND CONDITIONS, SPECIFICALLY THE WARRANTY THEREIN, WHICH COVERS THESE PRODUCTS.

**LIFE SUPPORT POLICY**

FAIRCHILD'S PRODUCTS ARE NOT AUTHORIZED FOR USE AS CRITICAL COMPONENTS IN LIFE SUPPORT DEVICES OR SYSTEMS WITHOUT THE EXPRESS WRITTEN APPROVAL OF FAIRCHILD SEMICONDUCTOR CORPORATION.

As used herein:

1. Life support devices or systems are devices or systems which, (a) are intended for surgical implant into the body or (b) support or sustain life, and (c) whose failure to perform when properly used in accordance with instructions for use provided in the labeling, can be reasonably expected to result in a significant injury of the user.
2. A critical component in any component of a life support, device, or system whose failure to perform can be reasonably expected to cause the failure of the life support device or system, or to affect its safety or effectiveness.

**ANTI-COUNTERFEITING POLICY**

Fairchild Semiconductor Corporation's Anti-Counterfeiting Policy. Fairchild's Anti-Counterfeiting Policy is also stated on our external website, [www.fairchildsemi.com](http://www.fairchildsemi.com), under Sales Support.

Counterfeiting of semiconductor parts is a growing problem in the industry. All manufacturers of semiconductor products are experiencing counterfeiting of their parts. Customers who inadvertently purchase counterfeit parts experience many problems such as loss of brand reputation, substandard performance, failed applications, and increased cost of production and manufacturing delays. Fairchild is taking strong measures to protect ourselves and our customers from the proliferation of counterfeit parts. Fairchild strongly encourages customers to purchase Fairchild parts either directly from Fairchild or from Authorized Fairchild Distributors who are listed by country on our web page cited above. Products customers buy either from Fairchild directly or from Authorized Fairchild Distributors are genuine parts, have full traceability, meet Fairchild's quality standards for handling and storage and provide access to Fairchild's full range of up-to-date technical and product information. Fairchild and our Authorized Distributors will stand behind all warranties and will appropriately address any warranty issues that may arise. Fairchild will not provide any warranty coverage or other assistance for parts bought from Unauthorized Sources. Fairchild is committed to combat this global problem and encourage our customers to do their part in stopping this practice by buying direct or from authorized distributors.

**PRODUCT STATUS DEFINITIONS**

**Definition of Terms**

Datasheet Identification	Product Status	Definition
Advance Information	Formative / In Design	Datasheet contains the design specifications for product development. Specifications may change in any manner without notice.
Preliminary	First Production	Datasheet contains preliminary data; supplementary data will be published at a later date. Fairchild Semiconductor reserves the right to make changes at any time without notice to improve design.
No Identification Needed	Full Production	Datasheet contains final specifications. Fairchild Semiconductor reserves the right to make changes at any time without notice to improve the design.
Obsolete	Not In Production	Datasheet contains specifications on a product that is discontinued by Fairchild Semiconductor. The datasheet is for reference information only.

Rev. I49