

## Tiny Package, Low Dropout Current Source

### General Description

The RT9300A/B low-dropout bias supply for white LEDs is a high-performance alternative to the simple ballast resistors used in conventional white LED designs. The RT9300A/B uses an internal resistor to set the bias current for four LEDs, which are matched to 5%. The RT9300A/B's advantages over ballast resistors include much lower bias variation with supply voltage variation, significantly lower dropout voltage, and in some applications, significantly improved efficiency. The RT9300A/B requires only a 60/45mV dropout voltage at a 20/15mA load on each output to match the LED brightness.

### Ordering Information

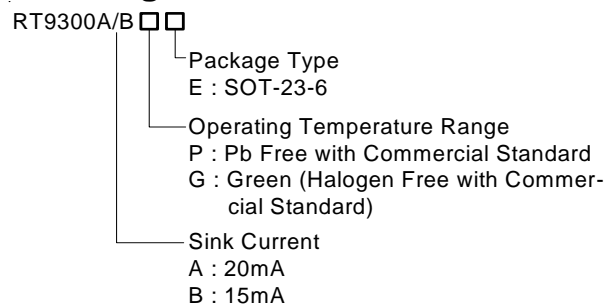

Note :

Richtek Pb-free and Green products are :

- ▶ RoHS compliant and compatible with the current requirements of IPC/JEDEC J-STD-020.
- ▶ Suitable for use in SnPb or Pb-free soldering processes.

### Features

- Low 60/45mV Dropout at 20/15mA
- 5% LED Current Matching
- Simple LED Brightness Control
- 2.5V to 5.5V Supply Voltage Range
- Thermal Shutdown Protection
- RoHS Compliant and 100% Lead (Pb)-Free

### Applications

- Next-Generation Wireless Handsets
- PDAs, Palmtops, and Handy Terminals
- Digital Cameras, Camcorders
- Battery-Powered Equipment

### Pin Configurations

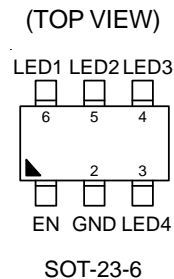

### Marking Information

For marking information, contact our sales representative directly or through a Richtek distributor located in your area, otherwise visit our website for detail.

### Typical Application Circuit

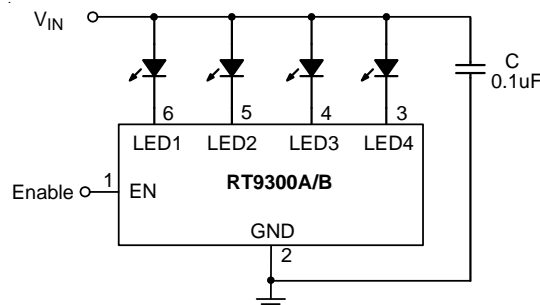

Figure 1. Application Circuit for Backlight.

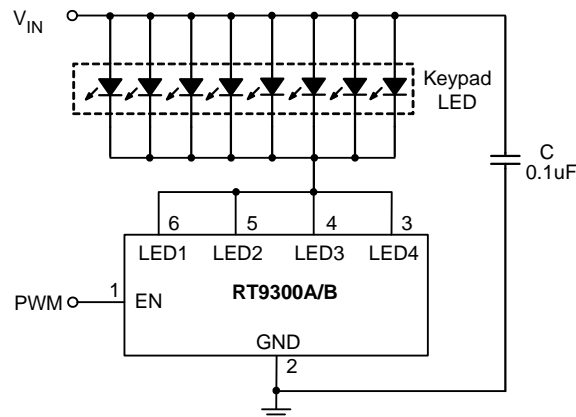
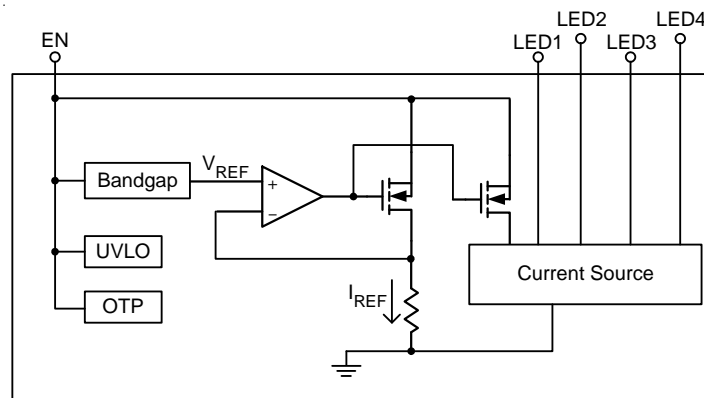

Figure 2. Application Circuit for Keypad.

### Function Block Diagram



### Functional Pin Description

Pin	Name	Function
1	EN	Chip Enable (Active High).
2	GND	Ground
3	LED4	LED4 Cathode Connection. Current flowing into LED4 is Constant. (20mA/15 mA) LED4 is High Impedance when EN is Low.
4	LED3	LED3 Cathode Connection. Current flowing into LED3 is Constant. (20mA/15 mA) LED3 is High Impedance when EN is Low.
5	LED2	LED2 Cathode Connection. Current flowing into LED2 is Constant. (20mA/15 mA) LED2 is High Impedance when EN is Low.
6	LED1	LED1 Cathode Connection. Current flowing into LED1 is Constant. (20mA/15 mA) LED1 is High Impedance when EN is Low.

**Absolute Maximum Ratings** (Note 1)

- Supply Input Voltage,  $V_{IN}$  ----- -0.3V to 6V
- The other pins ----- -0.3V to 6V
- Power Dissipation,  $P_D$  @  $T_A = 25^\circ\text{C}$   
   SOT-23-6 ----- 0.4W
- Package Thermal Resistance (Note 4)  
   SOT-23-6,  $\theta_{JA}$  ----- 250°C/W
- Lead Temperature (Soldering, 10 sec.) ----- 260°C
- Operation Temperature Range ----- -40°C to 85°C
- Junction Temperature ----- 150°C
- Storage Temperature Range ----- -65°C to 150°C
- ESD Susceptibility (Note 2)  
   HBM (Human Body Mode) ----- 2kV  
   MM (Machine Mode) ----- 200V

**Recommended Operating Conditions** (Note 3)

- Junction Temperature Range ----- -40°C to 125°C
- Ambient Temperature Range ----- -40°C to 85°C

**Electrical Characteristics**

( $V_{IN} = 3.7\text{V}$ ,  $T_A = 25^\circ\text{C}$ , Unless Otherwise specification)

Parameter	Symbol	Test Condition	Min	Typ	Max	Units
<b>System Supply Input</b>						
Operation Voltage Range	$V_{EN}$		2.5	--	5.5	V
Under Voltage Lock Out	$V(\text{UVLO})$	Falling	--	2.1	--	V
UVLO Hysteresis			--	100	--	mV
LED Sink Current		RT9300A	18	20	22	mA
		RT9300B	13.5	15	16.5	
Quiescent Current	$I_{EN}$	$I_{LED} = 0$	--	--	600	uA
LED Dropout Voltage		$I_{LED} = 20\text{mA}$	--	60	--	mV
		$I_{LED} = 15\text{mA}$	--	45	--	
LED Current Deviation Matching			--	--	5	%
EN High-Level Input Voltage	$V_{EN\_H}$		2.5	--	--	V
EN Low-Level Input Voltage	$V_{EN\_L}$		--	--	0.7	V
OTP			--	170	--	°C
OTP Hysteresis			--	10	--	°C
Shutdown Current	$I_{SHDN}$	$V_{EN} < 0.4\text{V}$	--	--	1	uA

**Note 1.** Stresses listed as the above "Absolute Maximum Ratings" may cause permanent damage to the device. These are for stress ratings. Functional operation of the device at these or any other conditions beyond those indicated in the operational sections of the specifications is not implied. Exposure to absolute maximum rating conditions for extended periods may remain possibility to affect device reliability.

**Note 2.** Devices are ESD sensitive. Handling precaution is recommended.

**Note 3.** The device is not guaranteed to function outside its operating conditions.

**Note 4.**  $\theta_{JA}$  is measured in the natural convection at  $T_A = 25^\circ\text{C}$  on a low effective single layer thermal conductivity test board of JEDEC 51-3 thermal measurement standard.

**Note 5.** Floating connection or pull low to disable this function.

**Typical Operating Characteristics**

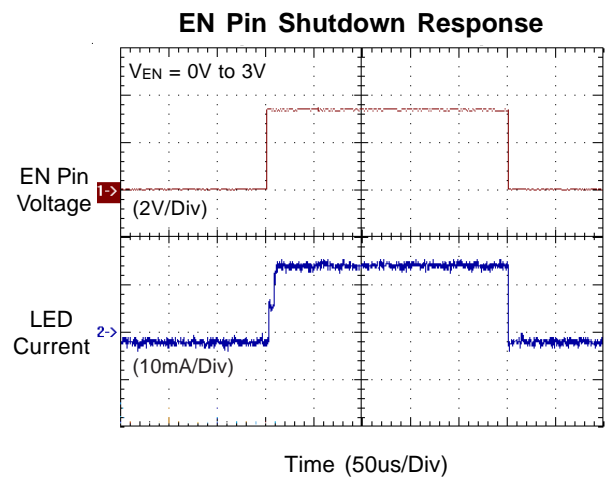
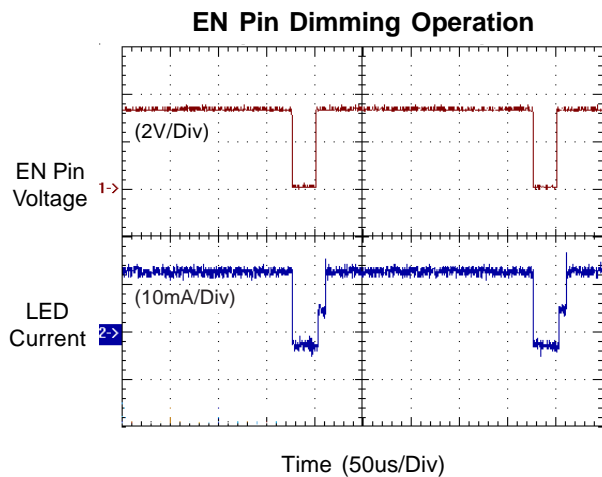
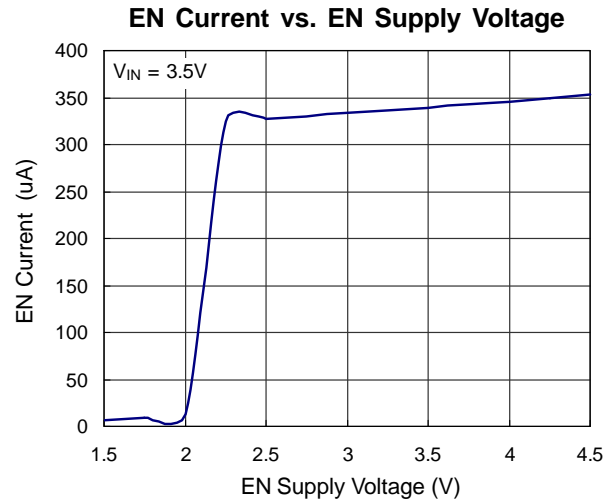
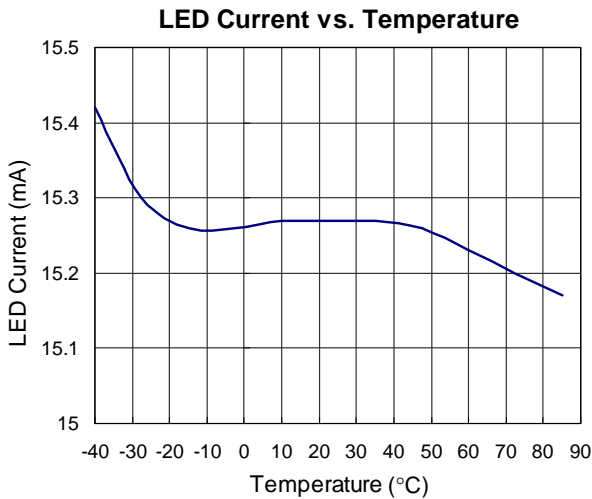
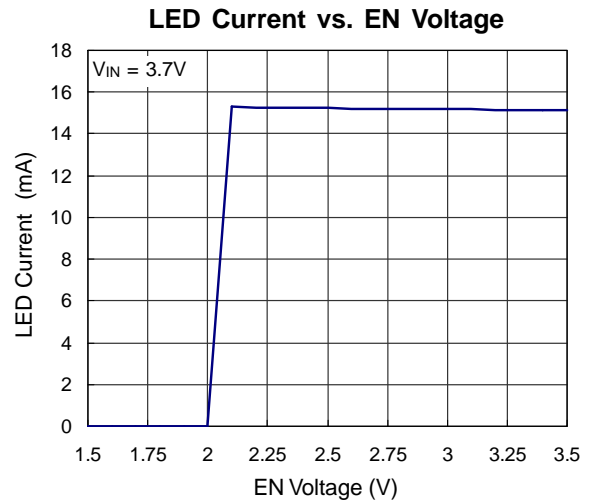
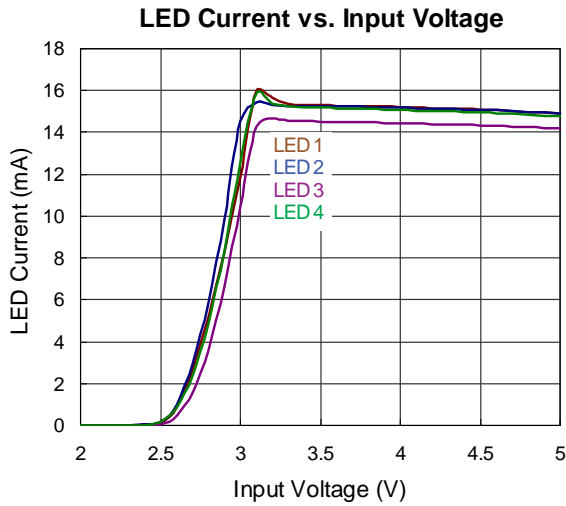

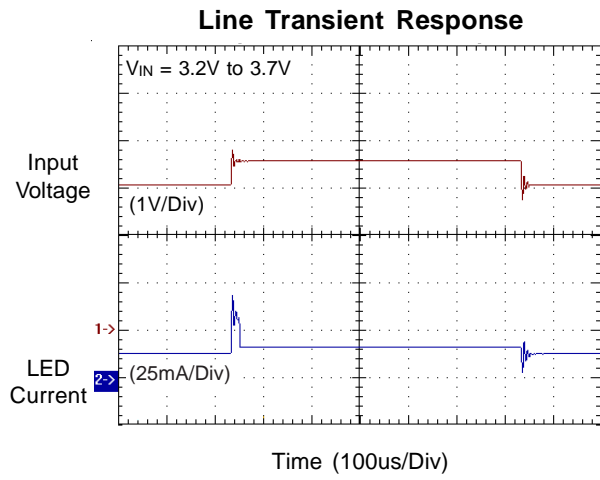

**Applications Information**

The RT9300A/B is a 4-Channel current source driver for white LEDs.

**Enable Input**

EN powers the input of the RT9300A/B. This IC provides an under voltage lockout (UVLO) function to prevent it from unstable issue when startup. The UVLO threshold of input falling voltage is set at 2.1V typically with a hysteresis 0.1V. Drive EN high to enable the device; drive EN low to disable the device. When driven high, EN draws 350uA to power the IC. Driving EN low forces LED1, LED2, LED3, and LED4 into a high-impedance state.

**LED Current**

RT9300A/B provides a constant current for white LED. Figure 1 shows a typical application circuit for 4 white LEDs. Each channel supports up to 20mA/15mA current and regulates a constant current for uniform intensity. For keypad LED application, the all channels must be connected to LED as shown in Figure 2. In order to maintain LED constant current, the input voltage must provide the required LED forward voltage and current source dropout voltage. If the forward voltage of white LEDs is 3.3V, the input voltage should be higher than 3.4V to provide enough voltage headroom for maintaining constant brightness.

**LED Brightness Dimming Control**

For controlling the LED brightness, the RT9300A/B can perform the dimming control by applying a PWM signal to EN pin. When an external PWM signal is connected to the EN pin, brightness of white LED is adjusted by the duty cycle. The average LED current is proportional to the PWM signal duty cycle. The magnitude of the PWM signal must be higher than the minimum level of enable input high level, in order to let the dimming control perform correctly, the suggested PWM frequency range is 10kHz to 200Hz.

**Thermal Considerations**

For continuous operation, do not exceed absolute maximum operation junction temperature 125°C. The maximum power dissipation depends on the thermal resistance of IC package, PCB layout, the rate of

surroundings airflow and temperature difference between junction to ambient. The maximum power dissipation can be calculated by following formula :

$$P_{D(MAX)} = ( T_{J(MAX)} - T_A ) / \theta_{JA}$$

Where  $T_{J(MAX)}$  is the maximum operation junction temperature 125°C,  $T_A$  is the ambient temperature and the  $\theta_{JA}$  is the junction to ambient thermal resistance.

For recommended operating conditions specification of RT9300, where  $T_{J(MAX)}$  is the maximum junction temperature of the die (125°C) and  $T_A$  is the maximum ambient temperature. The junction to ambient thermal resistance  $\theta_{JA}$  is layout dependent. For SOT-23-6 packages, the thermal resistance  $\theta_{JA}$  is 250°C/W on the standard JEDEC 51-3 single-layer thermal test board. The maximum power dissipation at  $T_A = 25^\circ\text{C}$  can be calculated by following formula :

$$P_{D(MAX)} = ( 125^\circ\text{C} - 25^\circ\text{C} ) / ( 250^\circ\text{C/W} ) = 0.4\text{W for SOT-23-6 packages}$$

The maximum power dissipation depends on operating ambient temperature for fixed  $T_{J(MAX)}$  and thermal resistance  $\theta_{JA}$ . For RT9300 packages, the Figure 1 of derating curves allows the designer to see the effect of rising ambient temperature on the maximum power allowed.

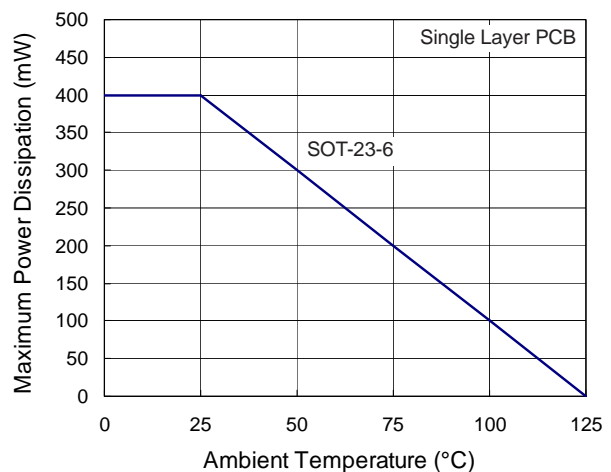

Figure 1. Derating Curves for RT9300 Packages

### Layout Considerations

For best performance, careful PCB layout is necessary. All peripheral components should be placed as close to the IC as possible. A short connection is highly recommended. The following guidelines should be strictly followed when designing a PCB layout for the RT9300A/B.

- ▶ All the traces of LED and VIN running from chip to LEDs should be wide and short to reduce the parasitic connection resistance.
- ▶ The capacitor should be placed close to the anodes of LEDs and connected to ground plane.
- ▶ The GND should be connected to a strong ground plane for heat sinking and noise protection.

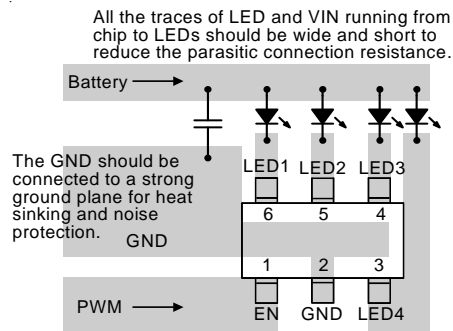
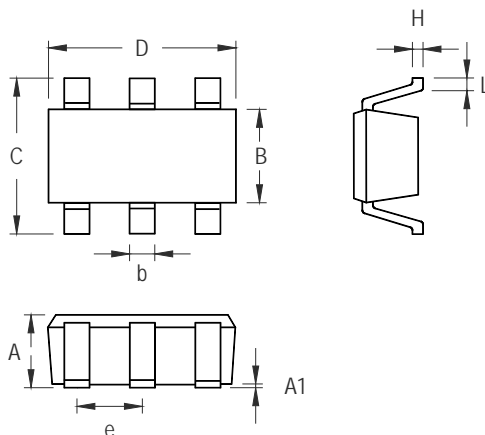

Figure 2



**Outline Dimension**



Symbol	Dimensions In Millimeters		Dimensions In Inches	
	Min	Max	Min	Max
A	0.889	1.295	0.031	0.051
A1	0.000	0.152	0.000	0.006
B	1.397	1.803	0.055	0.071
b	0.250	0.560	0.010	0.022
C	2.591	2.997	0.102	0.118
D	2.692	3.099	0.106	0.122
e	0.838	1.041	0.033	0.041
H	0.080	0.254	0.003	0.010
L	0.300	0.610	0.012	0.024

**SOT-23-6 Surface Mount Package**

**Richtek Technology Corporation**

Headquarter  
 5F, No. 20, Taiyuen Street, Chupei City  
 Hsinchu, Taiwan, R.O.C.  
 Tel: (8863)5526789 Fax: (8863)5526611

**Richtek Technology Corporation**

Taipei Office (Marketing)  
 8F, No. 137, Lane 235, Paochiao Road, Hsintien City  
 Taipei County, Taiwan, R.O.C.  
 Tel: (8862)89191466 Fax: (8862)89191465  
 Email: marketing@richtek.com

Information that is provided by Richtek Technology Corporation is believed to be accurate and reliable. Richtek reserves the right to make any change in circuit design, specification or other related things if necessary without notice at any time. No third party intellectual property infringement of the applications should be guaranteed by users when integrating Richtek products into any application. No legal responsibility for any said applications is assumed by Richtek.