

# LM3444

## AC-DC Offline LED Driver

### General Description

The LM3444 is an adaptive constant off-time AC/DC buck (step-down) constant current controller that provides a constant current for illuminating high power LEDs. The high frequency capable architecture allows the use of small external passive components. A passive PFC circuit ensures good power factor by drawing current directly from the line for most of the cycle, and provides a constant positive voltage to the buck regulator. Additional features include thermal shutdown, current limit and  $V_{CC}$  under-voltage lockout. The LM3444 is available in a low profile MSOP-10 package.

### Features

- Application voltage range  $80V_{AC} - 277V_{AC}$
- Capable of controlling LED currents greater than 1A
- Adjustable switching frequency
- Low quiescent current
- Adaptive programmable off-time allows for constant ripple current
- Thermal shutdown
- No 120Hz flicker
- Low profile 10 pin MSOP package
- Patent pending drive architecture

### Applications

- Solid State Lighting
- Industrial and Commercial Lighting
- Residential Lighting

### Typical LM3444 LED Driver Application Circuit

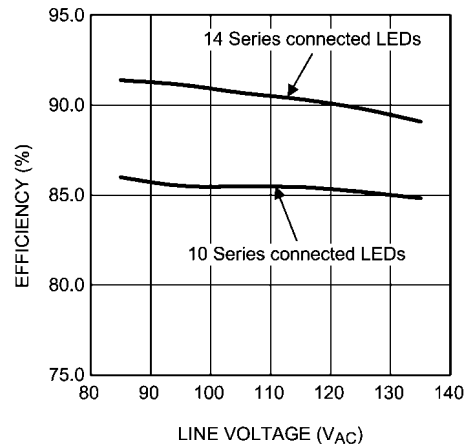
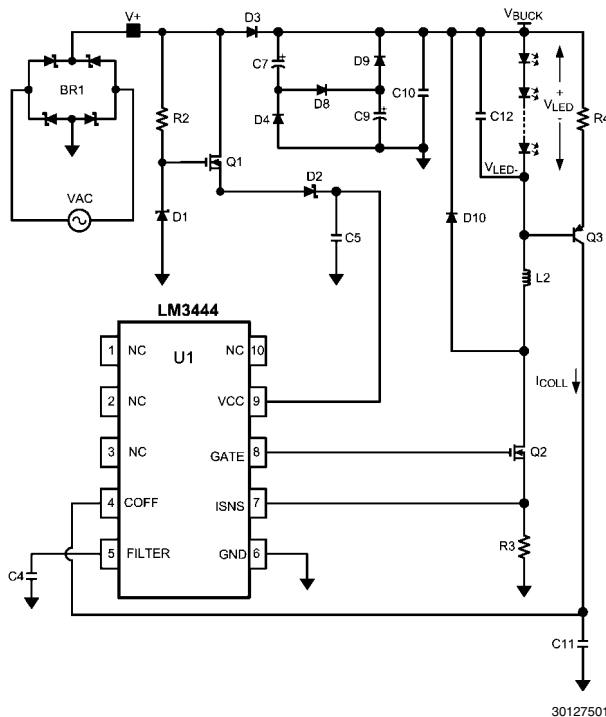

30127505

## Connection Diagram

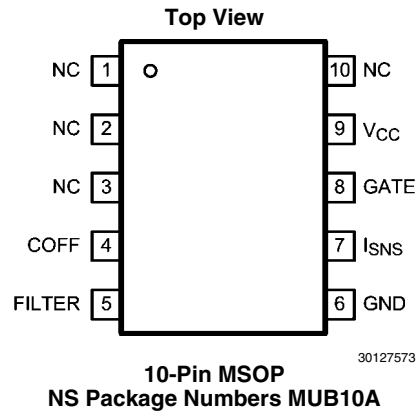

## Ordering Information

Order Number	Spec.	Package Type	NSC Package Drawing	Top Mark	Supplied As
LM3444MM	NOPB	MSOP-10	MUB10A	SZTB	1000 Units, Tape and Reel
LM3444MMX	NOPB	MSOP-10	MUB10A	SZTB	3500 Units, Tape and Reel

## Pin Descriptions

MSOP	Name	Description
1	NC	No internal connection. Leave this pin open.
2	NC	No internal connection. Leave this pin open.
3	NC	No internal connection. Leave this pin open.
4	COFF	OFF time setting pin. A user set current and capacitor connected from the output to this pin sets the constant OFF time of the switching controller.
5	FILTER	Filter input. A low pass filter tied to this pin can filter a PWM dimming signal to supply a DC voltage to control the LED current. Can also be used as an analog dimming input. If not used for dimming connect a 0.1 $\mu$ F capacitor from this pin to ground.
6	PGND	Circuit ground connection.
7	ISNS	LED current sense pin. Connect a resistor from main switching MOSFET source, ISNS to GND to set the maximum LED current.
8	GATE	Power MOSFET driver pin. This output provides the gate drive for the power switching MOSFET of the buck controller.
9	V <sub>CC</sub>	Input voltage pin. This pin provides the power for the internal control circuitry and gate driver.
10	NC	No internal connection. Leave this pin open.

## Absolute Maximum Ratings *(Note 1)*

If Military/Aerospace specified devices are required, please contact the National Semiconductor Sales Office/Distributors for availability and specifications.

$V_{CC}$ and GATE to GND	-0.3V to +14V
ISNS to GND	-0.3V to +2.5V
FILTER and COFF to GND	-0.3V to +7.0V
COFF Input Current	60mA
Continuous Power Dissipation	Internally Limited

*(Note 2)*

ESD Susceptibility

HBM <i>(Note 3)</i>	2 kV
Junction Temperature ( $T_{J-MAX}$ )	150°C
Storage Temperature Range	-65°C to +150°C
Maximum Lead Temp. Range (Soldering)	260°C

## Operating Conditions

$V_{CC}$	8.0V to 13V
Junction Temperature	-40°C to +125°C

**Electrical Characteristics** Limits in standard type face are for  $T_J = 25^\circ\text{C}$  and those with **boldface type** apply over the full **Operating Temperature Range** ( $T_J = -40^\circ\text{C}$  to  $+125^\circ\text{C}$ ). Minimum and Maximum limits are guaranteed through test, design, or statistical correlation. Typical values represent the most likely parametric norm at  $T_J = +25^\circ\text{C}$ , and are provided for reference purposes only. Unless otherwise stated the following conditions apply:  $V_{CC} = 12\text{V}$ .

Symbol	Parameter	Conditions	Min	Typ	Max	Units
<b><math>V_{CC}</math> SUPPLY</b>						
$I_{VCC}$	Operating supply current			1.58	<b>2.25</b>	mA
$V_{CC-UVLO}$	Rising threshold			7.4	<b>7.7</b>	V
	Falling threshold		<b>6.0</b>	6.4		
	Hysteresis			1		
<b>COFF</b>						
$V_{COFF}$	Time out threshold		<b>1.225</b>	1.276	<b>1.327</b>	V
$R_{COFF}$	Off timer sinking impedance			33	<b>60</b>	$\Omega$
$t_{COFF}$	Restart timer			180		$\mu\text{s}$
<b>CURRENT LIMIT</b>						
$V_{ISNS}$	ISNS limit threshold		<b>1.174</b>	1.269	<b>1.364</b>	V
$t_{ISNS}$	Leading edge blanking time			125		ns
	Current limit reset delay			180		$\mu\text{s}$
	ISNS limit to GATE delay	ISNS = 0 to 1.75V step		33		ns
<b>CURRENT SENSE COMPARATOR</b>						
$V_{FILTER}$	FILTER open circuit voltage		<b>720</b>	750	<b>780</b>	mV
$R_{FILTER}$	FILTER impedance			1.12		$M\Omega$
$V_{OS}$	Current sense comparator offset voltage		<b>-4.0</b>	0.1	<b>4.0</b>	mV
<b>GATE DRIVE OUTPUT</b>						
$V_{DRVH}$	GATE high saturation	$I_{GATE} = 50\text{ mA}$		0.24	<b>0.50</b>	V
$V_{DRVL}$	GATE low saturation	$I_{GATE} = 100\text{ mA}$		0.22	<b>0.50</b>	
$I_{DRV}$	Peak source current	$GATE = V_{CC}/2$		-0.77		A
	Peak sink current	$GATE = V_{CC}/2$		0.88		
$t_{DV}$	Rise time	$C_{load} = 1\text{ nF}$		15		ns
	Fall time	$C_{load} = 1\text{ nF}$		15		
<b>THERMAL SHUTDOWN</b>						
$T_{SD}$	Thermal shutdown temperature	<i>(Note 4)</i>		165		$^\circ\text{C}$
	Thermal shutdown hysteresis			20		
<b>THERMAL SPECIFICATION</b>						
$R_{\theta JA}$	MSOP-10 junction to ambient			124		$^\circ\text{C/W}$
$R_{\theta JC}$	MSOP-10 junction to case			76		

**Note 1:** Absolute maximum ratings are limits beyond which damage to the device may occur. Operating Ratings are conditions for which the device is intended to be functional, but device parameter specifications may not be guaranteed. For guaranteed specifications and test conditions, see the Electrical Characteristics. All voltages are with respect to the potential at the GND pin, unless otherwise specified.

**Note 2:** Internal thermal shutdown circuitry protects the device from permanent damage. Thermal shutdown engages at  $T_J = 165^\circ\text{C}$  (typ.) and disengages at  $T_J = 145^\circ\text{C}$  (typ.).

**Note 3:** Human Body Model, applicable std. JESD22-A114-C.

**Note 4:** Junction-to-ambient thermal resistance is highly application and board-layout dependent. In applications where high maximum power dissipation exists, special care must be paid to thermal dissipation issues in board design. In applications where high power dissipation and/or poor package thermal resistance is present, the maximum ambient temperature may have to be derated. Maximum ambient temperature ( $T_{A-MAX}$ ) is dependent on the maximum operating junction temperature ( $T_{J-MAX-OP} = 125^{\circ}C$ ), the maximum power dissipation of the device in the application ( $P_{D-MAX}$ ), and the junction-to-ambient thermal resistance of the part/package in the application ( $R_{\theta JA}$ ), as given by the following equation:  $T_{A-MAX} = T_{J-MAX-OP} - (R_{\theta JA} \times P_{D-MAX})$ .

## Typical Performance Characteristics

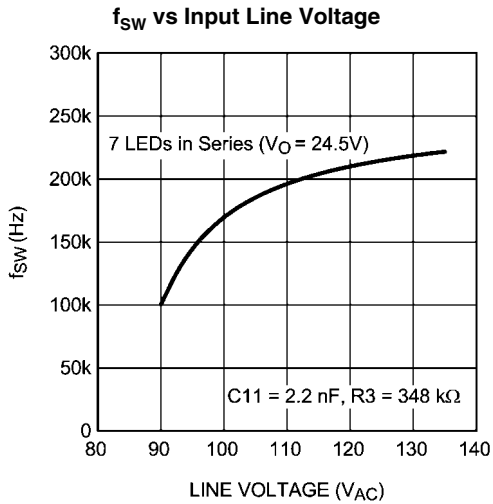

30127504

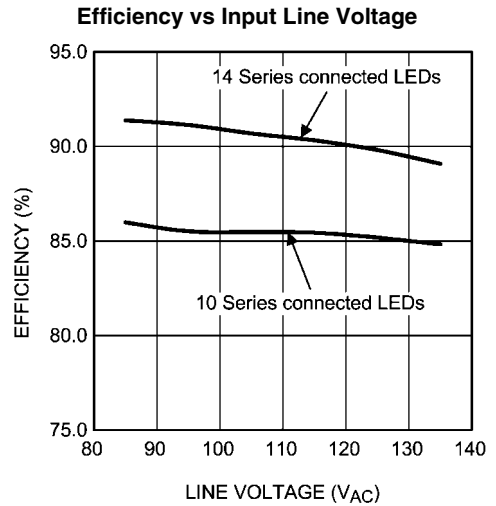

30127505

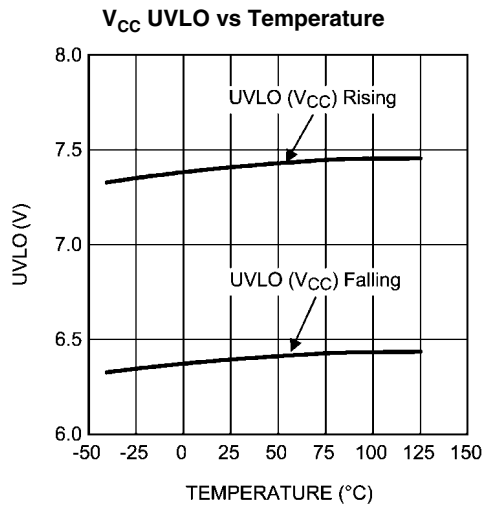

30127507

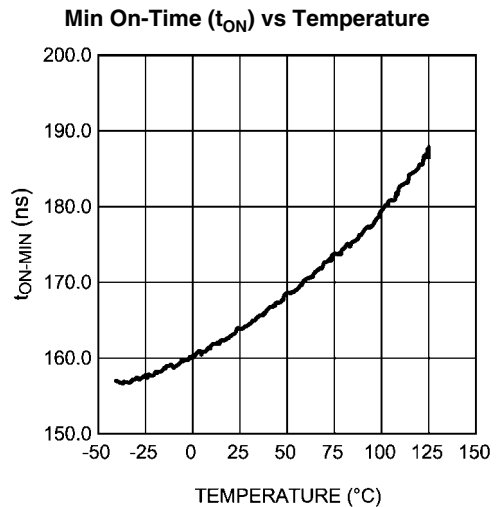

30127508

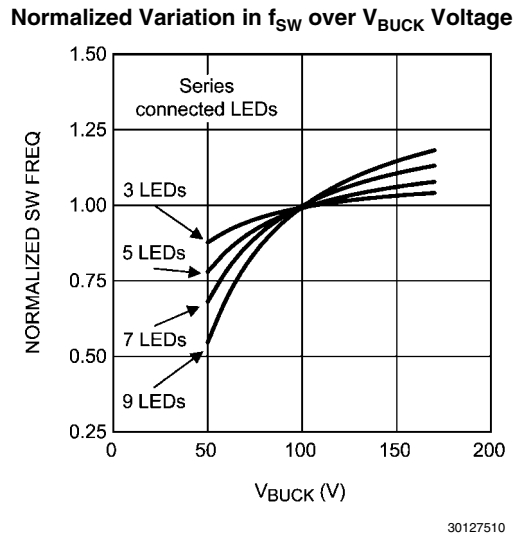
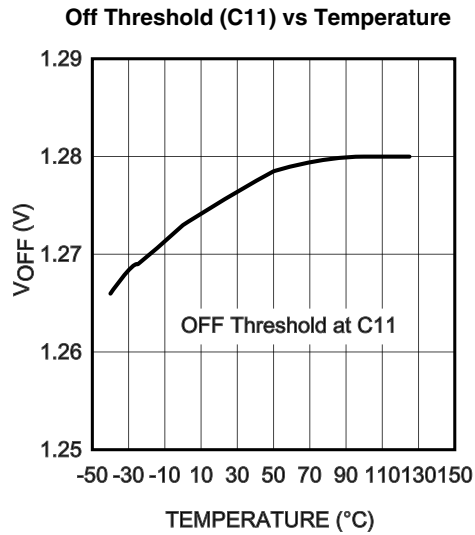

### Leading Edge Blanking Variation Over Temperature

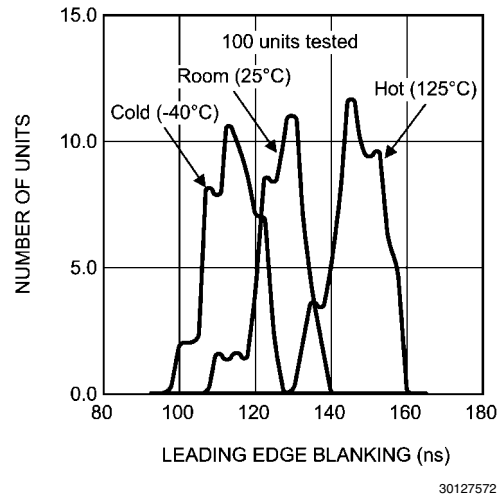

# Simplified Internal Block Diagram

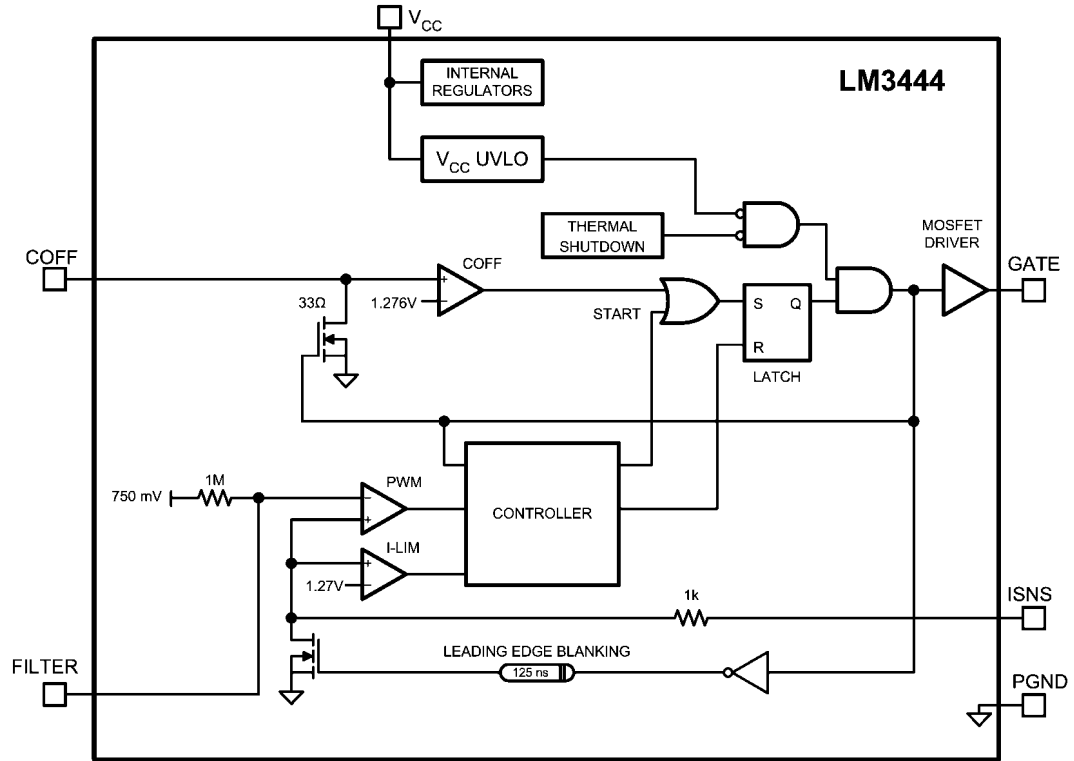

30127511

**FIGURE 1. Simplified Block Diagram**

## Application Information

### FUNCTIONAL DESCRIPTION

The LM3444 contains all the necessary circuitry to build a line-powered (mains powered) constant current LED driver.

## Theory of Operation

Refer to *Figure 2* below which shows the LM3444 along with basic external circuitry.

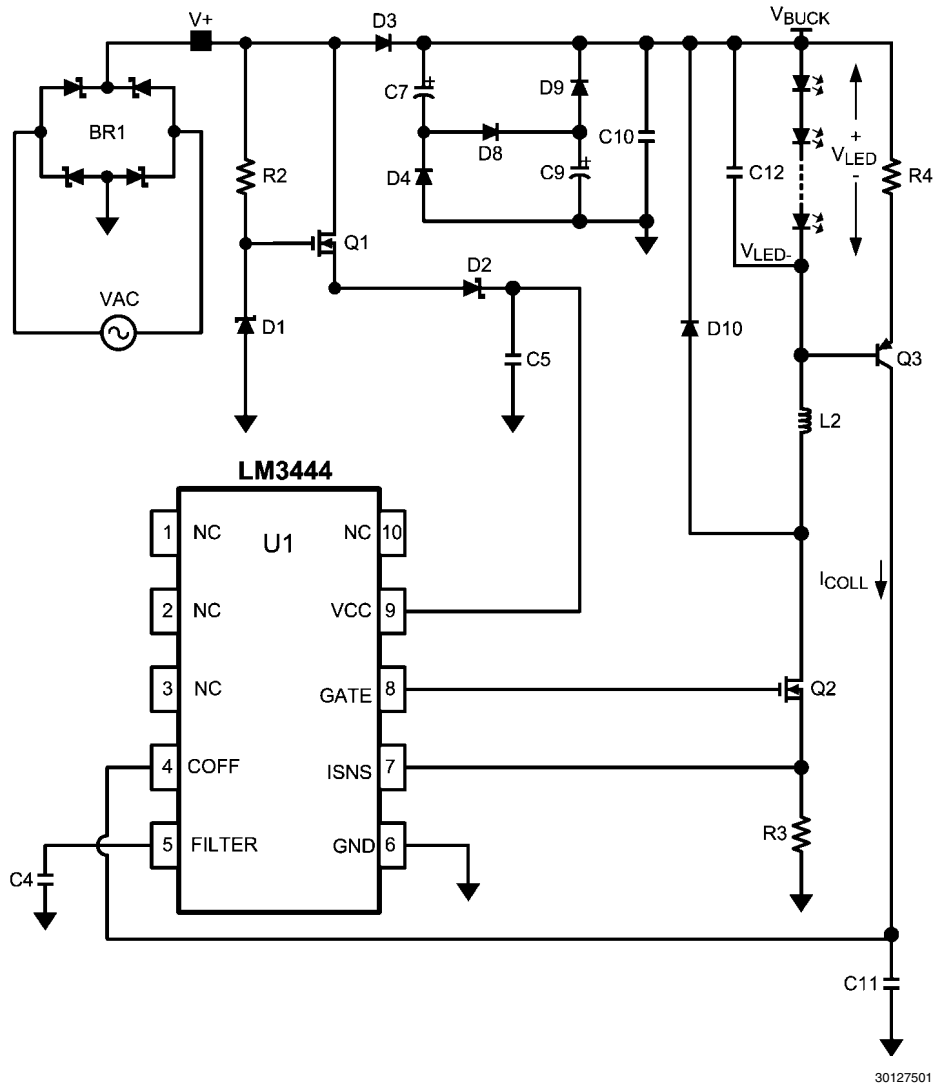
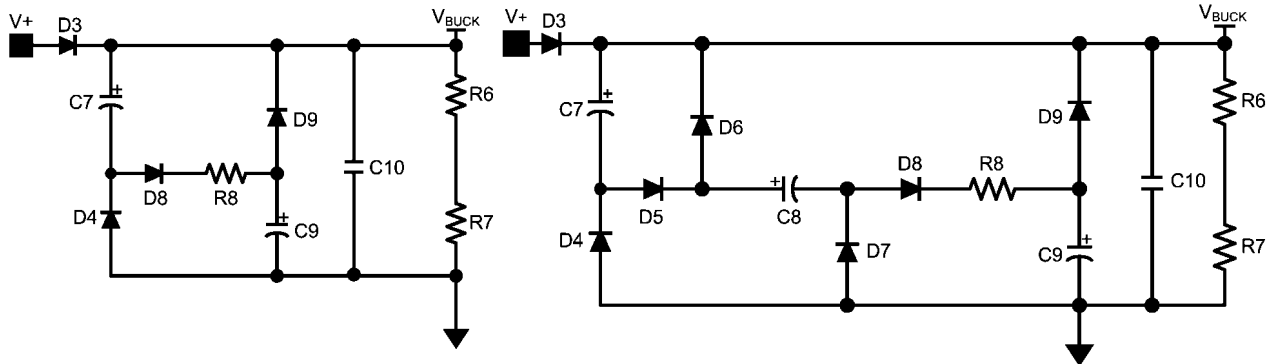

FIGURE 2. LM3444 Schematic

### VALLEY-FILL CIRCUIT

$V_{BUCK}$  supplies the power which drives the LED string. Diode D3 allows  $V_{BUCK}$  to remain high while  $V_+$  cycles on and off.  $V_{BUCK}$  has a relatively small hold capacitor C10 which reduces the voltage ripple when the valley fill capacitors are being

charged. However, the network of diodes and capacitors shown between D3 and C10 make up a "valley-fill" circuit. The valley-fill circuit can be configured with two or three stages. Figure 3 illustrates a two and three stage valley-fill circuit.



30127518

FIGURE 3. Two and Three Stage Valley Fill Circuit

The valley-fill circuit allows the buck regulator to draw power throughout a larger portion of the AC line. This allows the capacitance needed at  $V_{BUCK}$  to be lower than if there were no valley-fill circuit, and adds passive power factor correction (PFC) to the application.

### VALLEY-FILL OPERATION

When the "input line is high", power is derived directly through D3. The term "input line is high" can be explained as follows. The valley-fill circuit charges capacitors C7 and C9 in series (Figure 4) when the input line is high.

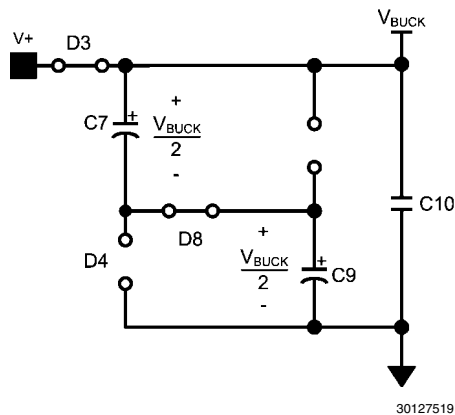

30127519

FIGURE 4. Two stage Valley-Fill Circuit when AC Line is High

The peak voltage of a two stage valley-fill capacitor is:

$$V_{VF-CAP} = \frac{V_{AC-RMS}\sqrt{2}}{2}$$

As the AC line decreases from its peak value every cycle, there will be a point where the voltage magnitude of the AC line is equal to the voltage that each capacitor is charged. At this point diode D3 becomes reversed biased, and the ca-

pacitors are placed in parallel to each other (Figure 5), and  $V_{BUCK}$  equals the capacitor voltage.

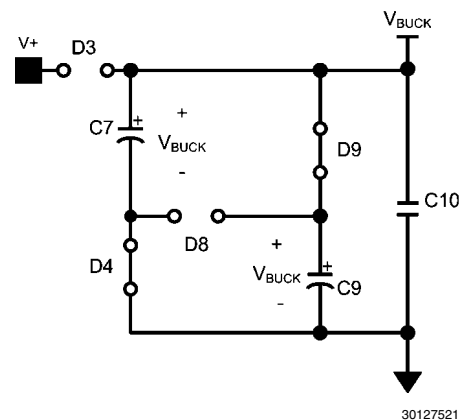

30127521

FIGURE 5. Two stage Valley-Fill Circuit when AC Line is Low

A three stage valley-fill circuit performs exactly the same as two-stage valley-fill circuit except now three capacitors are now charged in series, and when the line voltage decreases to:

$$V_{VF-CAP} = \frac{V_{AC-RMS}\sqrt{2}}{3}$$

Diode D3 is reversed biased and three capacitors are in parallel to each other.

The valley-fill circuit can be optimized for power factor, voltage hold up and overall application size and cost. The LM3444 will operate with a single stage or a three stage valley-fill circuit as well. Resistor R8 functions as a current limiting resistor during start-up, and during the transition from series to parallel connection. Resistors R6 and R7 are 1 MΩ bleeder resistors, and may or may not be necessary for each application.



## BUCK CONVERTER

The LM3444 is a buck controller that uses a proprietary constant off-time method to maintain constant current through a string of LEDs. While transistor Q2 is on, current ramps up through the inductor and LED string. A resistor R3 senses this current and this voltage is compared to the reference voltage at FILTER. When this sensed voltage is equal to the reference

voltage, transistor Q2 is turned off and diode D10 conducts the current through the inductor and LEDs. Capacitor C12 eliminates most of the ripple current seen in the inductor. Resistor R4, capacitor C11, and transistor Q3 provide a linear current ramp that sets the constant off-time for a given output voltage.

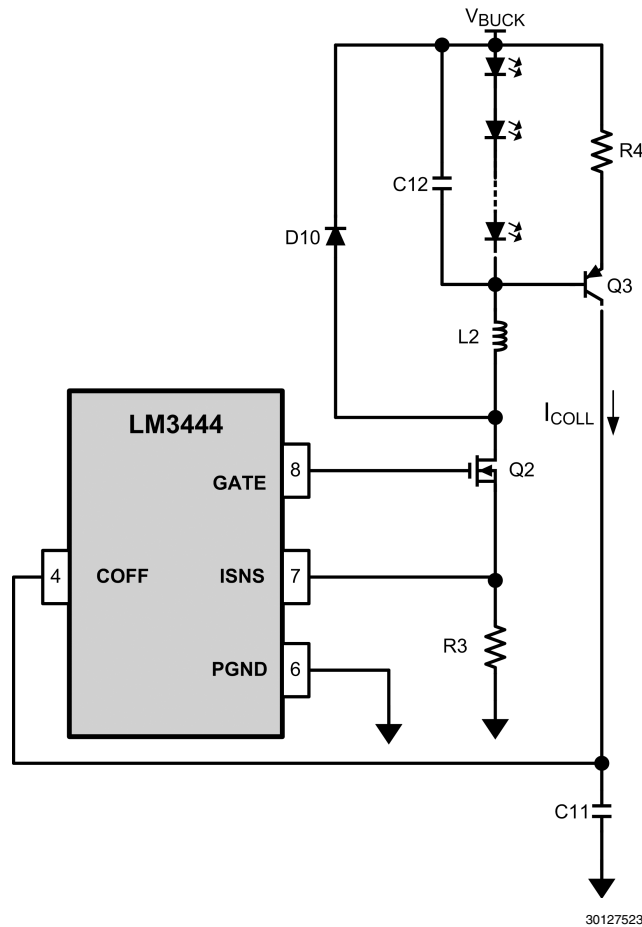

FIGURE 6. LM3444 Buck Regulation Circuit

## OVERVIEW OF CONSTANT OFF-TIME CONTROL

A buck converter's conversion ratio is defined as:

$$\frac{V_O}{V_{IN}} = D = \frac{t_{ON}}{t_{ON} + t_{OFF}} = t_{ON} \times f_{SW}$$

Constant off-time control architecture operates by simply defining the off-time and allowing the on-time, and therefore the switching frequency, to vary as either  $V_{IN}$  or  $V_O$  changes. The output voltage is equal to the LED string voltage ( $V_{LED}$ ), and should not change significantly for a given application. The input voltage or  $V_{BUCK}$  in this analysis will vary as the input line varies. The length of the on-time is determined by the sensed inductor current through a resistor to a voltage reference at a comparator. During the on-time, denoted by  $t_{ON}$ , MOSFET switch Q2 is on causing the inductor current to increase. During the on-time, current flows from  $V_{BUCK}$ , through the LEDs, through L2, Q2, and finally through R3 to ground. At some point in time, the inductor current reaches a maximum ( $I_{L2-PK}$ ) determined by the voltage sensed at R3 and

the ISNS pin. This sensed voltage across R3 is compared against the voltage of FILTER, at which point Q2 is turned off by the controller.

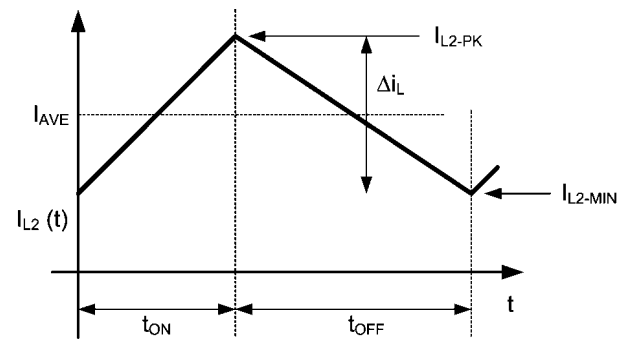

FIGURE 7. Inductor Current Waveform in CCM

During the off-period denoted by  $t_{OFF}$ , the current through L2 continues to flow through the LEDs via D10.

### THERMAL SHUTDOWN

Thermal shutdown limits total power dissipation by turning off the output switch when the IC junction temperature exceeds 165°C. After thermal shutdown occurs, the output switch doesn't turn on until the junction temperature drops to approximately 145°C.

## Design Guide

### DETERMINING DUTY-CYCLE (D)

Duty cycle (D) approximately equals:

$$\frac{V_{LED}}{V_{BUCK}} = D = \frac{t_{ON}}{t_{ON} + t_{OFF}} = t_{ON} \times f_{SW}$$

With efficiency considered:

$$\frac{1}{\eta} \times \frac{V_{LED}}{V_{BUCK}} = D$$

For simplicity, choose efficiency between 75% and 85%.

### CALCULATING OFF-TIME

The "Off-Time" of the LM3444 is set by the user and remains fairly constant as long as the voltage of the LED stack remains constant. Calculating the off-time is the first step in determining the switching frequency of the converter, which is integral in determining some external component values.

PNP transistor Q3, resistor R4, and the LED string voltage define a charging current into capacitor C11. A constant current into a capacitor creates a linear charging characteristic.

$$i = C \frac{dv}{dt}$$

Resistor R4, capacitor C11 and the current through resistor R4 ( $i_{COLL}$ ), which is approximately equal to  $V_{LED}/R4$ , are all fixed. Therefore,  $dv$  is fixed and linear, and  $dt$  ( $t_{OFF}$ ) can now be calculated.

$$t_{OFF} = C11 \times 1.276V \times \left( \frac{R4}{V_{LED}} \right)$$

Common equations for determining duty cycle and switching frequency in any buck converter:

$$f_{SW} = \frac{1}{t_{OFF} + t_{ON}}$$

$$D = \frac{t_{ON}}{t_{ON} + t_{OFF}} = \frac{V_{LED}}{V_{BUCK}}$$

$$D' = \frac{t_{OFF}}{t_{ON} + t_{OFF}}$$

Therefore:

$$f_{SW} = \frac{D}{t_{ON}}, \text{ and } f_{SW} = \frac{1 - D}{t_{OFF}}$$

With efficiency of the buck converter in mind:

$$\frac{V_{LED}}{V_{BUCK}} = \eta \times D$$

Substitute equations and rearrange:

$$f_{SW} = \frac{\left( 1 - \frac{1}{\eta} \times \frac{V_{LED}}{V_{BUCK}} \right)}{t_{OFF}}$$

Off-time, and switching frequency can now be calculated using the equations above.

### SETTING THE SWITCHING FREQUENCY

Selecting the switching frequency for nominal operating conditions is based on tradeoffs between efficiency (better at low frequency) and solution size/cost (smaller at high frequency).

The input voltage to the buck converter ( $V_{BUCK}$ ) changes with both line variations and over the course of each half-cycle of the input line voltage. The voltage across the LED string will, however, remain constant, and therefore the off-time remains constant.

The on-time, and therefore the switching frequency, will vary as the  $V_{BUCK}$  voltage changes with line voltage. A good design practice is to choose a desired nominal switching frequency knowing that the switching frequency will decrease as the line voltage drops and increase as the line voltage increases (Figure 8).

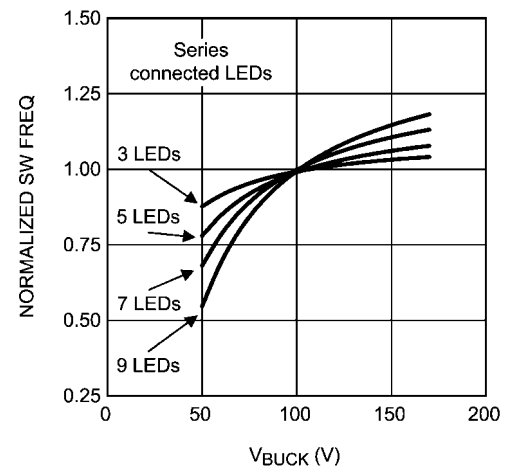

30127510

**FIGURE 8. Graphical Illustration of Switching Frequency vs  $V_{BUCK}$**

The off-time of the LM3444 can be programmed for switching frequencies ranging from 30 kHz to over 1 MHz. A trade-off between efficiency and solution size must be considered when designing the LM3444 application.

The maximum switching frequency attainable is limited only by the minimum on-time requirement (200 ns).

Worst case scenario for minimum on time is when  $V_{BUCK}$  is at its maximum voltage (AC high line) and the LED string voltage ( $V_{LED}$ ) is at its minimum value.

$$t_{ON(MIN)} = \left( \frac{1}{\eta} \times \frac{V_{LED(MIN)}}{V_{BUCK(MAX)}} \right) \frac{1}{f_{SW}}$$

The maximum voltage seen by the Buck Converter is:

$$V_{BUCK(MAX)} = V_{AC-RMS(MAX)} \times \sqrt{2}$$

### INDUCTOR SELECTION

The controlled off-time architecture of the LM3444 regulates the average current through the inductor ( $L2$ ), and therefore the LED string current. The input voltage to the buck converter ( $V_{BUCK}$ ) changes with line variations and over the course of each half-cycle of the input line voltage. The voltage across the LED string is relatively constant, and therefore the current through R4 is constant. This current sets the off-time of the converter and therefore the output volt-second product ( $V_{LED} \times \text{off-time}$ ) remains constant. A constant volt-second product makes it possible to keep the ripple through the inductor constant as the voltage at  $V_{BUCK}$  varies.

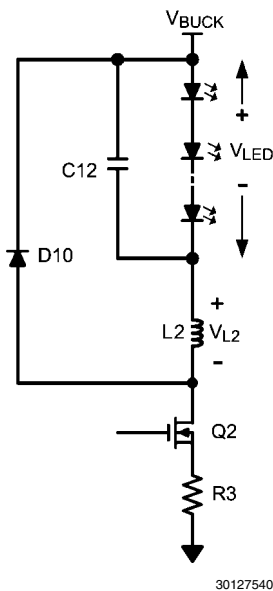

**FIGURE 9. LM3444 External Components of the Buck Converter**

The equation for an ideal inductor is:

$$v = L \frac{di}{dt}$$

Given a fixed inductor value,  $L$ , this equation states that the change in the inductor current over time is proportional to the voltage applied across the inductor.

During the on-time, the voltage applied across the inductor is,

$$V_{L(ON-TIME)} = V_{BUCK} - (V_{LED} + V_{DS(Q2)} + I_{L2} \times R3)$$

Since the voltage across the MOSFET switch ( $Q2$ ) is relatively small, as is the voltage across sense resistor  $R3$ , we can simplify this to approximately,

$$V_{L(ON-TIME)} = V_{BUCK} - V_{LED}$$

During the off-time, the voltage seen by the inductor is approximately:

$$V_{L(OFF-TIME)} = V_{LED}$$

The value of  $V_{L(OFF-TIME)}$  will be relatively constant, because the LED stack voltage will remain constant. If we rewrite the equation for an inductor inserting what we know about the circuit during the off-time, we get:

$$V_{L(OFF-TIME)} = V_{LED} = L \times \frac{\Delta i}{\Delta t}$$

$$V_{L(OFF-TIME)} = V_{LED} = L \times \frac{(I_{L(MAX)} - I_{L(MIN)})}{\Delta t}$$

Re-arranging this gives:

$$\Delta i \cong t_{OFF} \times \frac{V_{LED}}{L2}$$

From this we can see that the ripple current ( $\Delta i$ ) is proportional to off-time ( $t_{OFF}$ ) multiplied by a voltage which is dominated by  $V_{LED}$  divided by a constant ( $L2$ ).

These equations can be rearranged to calculate the desired value for inductor  $L2$ .

$$L2 \cong t_{OFF} \times \frac{V_{LED}}{\Delta i}$$

Where:

$$t_{OFF} = \left( 1 - \frac{1}{\eta} \times \frac{V_{LED}}{V_{BUCK}} \right) \frac{1}{f_{SW}}$$

Finally:

$$L2 = \frac{V_{LED} \left( 1 - \frac{1}{\eta} \times \frac{V_{LED}}{V_{BUCK}} \right)}{f_{SW} \times \Delta i}$$

Refer to "Design Example" section of the datasheet to better understand the design process.

### SETTING THE LED CURRENT

The LM3444 constant off-time control loop regulates the peak inductor current ( $I_{L2}$ ). The average inductor current equals the average LED current ( $I_{AVE}$ ). Therefore the average LED current is regulated by regulating the peak inductor current.

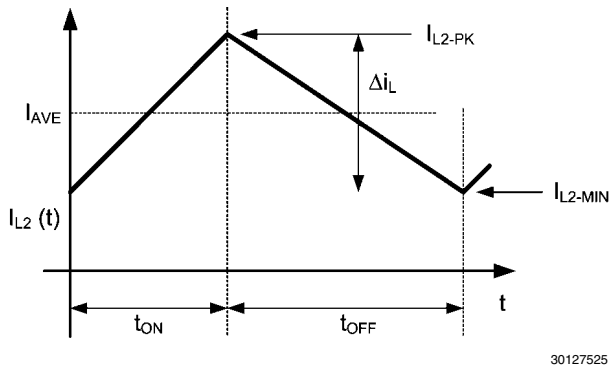

**FIGURE 10. Inductor Current Waveform in CCM**

Knowing the desired average LED current,  $I_{AVE}$  and the nominal inductor current ripple,  $\Delta i_L$ , the peak current for an application running in continuous conduction mode (CCM) is defined as follows:

$$I_{L2-PK} = I_{AVE} + \frac{\Delta i_L}{2}$$

Or the LED current would then be,

$$I_{AVE(UNDIM)} = I_{L2-PK(UNDIM)} - \frac{\Delta i_L}{2}$$

This is important to calculate because this peak current multiplied by the sense resistor R3 will determine when the internal comparator is tripped. The internal comparator turns the control MOSFET off once the peak sensed voltage reaches 750 mV.

$$I_{L-PK(UNDIM)} = \frac{750 \text{ mV}}{R3}$$

**Current Limit:** The trip voltage on the PWM comparator is 750 mV. However, if there is a short circuit or an excessive load on the output, higher than normal switch currents will cause a voltage above 1.27V on the ISNS pin which will trip the I-LIM comparator. The I-LIM comparator will reset the RS latch, turning off Q2. It will also inhibit the Start Pulse Generator and the COFF comparator by holding the COFF pin low. A delay circuit will prevent the start of another cycle for 180  $\mu$ s.

### VALLEY FILL CAPACITORS

Determining voltage rating and capacitance value of the valley-fill capacitors:

The maximum voltage seen by the valley-fill capacitors is:

$$V_{VF-CAP} = \frac{V_{AC(MAX)}\sqrt{2}}{\#stages}$$

This is, of course, if the capacitors chosen have identical capacitance values and split the line voltage equally. Often a 20% difference in capacitance could be observed between like capacitors. Therefore a voltage rating margin of 25% to 50% should be considered.

**Determining the capacitance value of the valley-fill capacitors:**

The valley fill capacitors should be sized to supply energy to the buck converter ( $V_{BUCK}$ ) when the input line is less than its peak divided by the number of stages used in the valley fill ( $t_x$ ). The capacitance value should be calculated for the maximum LED current.

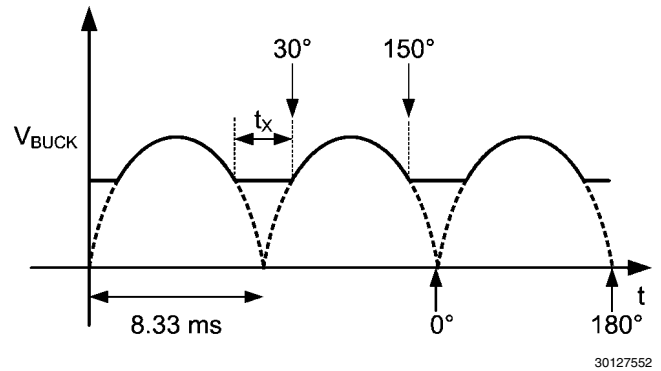

**FIGURE 11. Two Stage Valley-Fill  $V_{BUCK}$  Voltage**

From the above illustration and the equation for current in a capacitor,  $i = C \times dV/dt$ , the amount of capacitance needed at  $V_{BUCK}$  will be calculated as follows:

At 60Hz, and a valley-fill circuit of two stages, the hold up time ( $t_x$ ) required at  $V_{BUCK}$  is calculated as follows. The total angle of an AC half cycle is 180° and the total time of a half AC line cycle is 8.33 ms. When the angle of the AC waveform is at 30° and 150°, the voltage of the AC line is exactly 1/2 of its peak. With a two stage valley-fill circuit, this is the point where the LED string switches from power being derived from AC line to power being derived from the hold up capacitors (C7 and C9). 60° out of 180° of the cycle or 1/3 of the cycle the power is derived from the hold up capacitors (1/3 x 8.33 ms = 2.78 ms). This is equal to the hold up time (dt) from the above equation, and dv is the amount of voltage the circuit is allowed to droop. From the next section ("Determining Maximum Number of Series Connected LEDs Allowed") we know the minimum  $V_{BUCK}$  voltage will be about 45V for a 90V<sub>AC</sub> to 135V<sub>AC</sub> line. At 90V<sub>AC</sub> low line operating condition input, 1/2 of the peak voltage is 64V. Therefore with some margin the voltage at  $V_{BUCK}$  can not droop more than about 15V (dv). (i) is equal to ( $P_{OUT}/V_{BUCK}$ ), where  $P_{OUT}$  is equal to ( $V_{LED} \times I_{LED}$ ). Total capacitance (C7 in parallel with C9) can now be calculated. See "Design Example" section for further calculations of the valley-fill capacitors.

### Determining Maximum Number of Series Connected LEDs Allowed:

The LM3444 is an off-line buck topology LED driver. A buck converter topology requires that the input voltage ( $V_{BUCK}$ ) of the output circuit must be greater than the voltage of the LED stack ( $V_{LED}$ ) for proper regulation. One must determine what the minimum voltage observed by the buck converter will be before the maximum number of LEDs allowed can be determined. Two variables will have to be determined in order to accomplish this.

1. AC line operating voltage. This is usually 90V<sub>AC</sub> to 135V<sub>AC</sub> for North America. Although the LM3444 can operate at much lower and higher input voltages a range is needed to illustrate the design process.
2. How many stages are implemented in the valley-fill circuit (1, 2 or 3).

In this example the most common valley-fill circuit will be used (two stages).

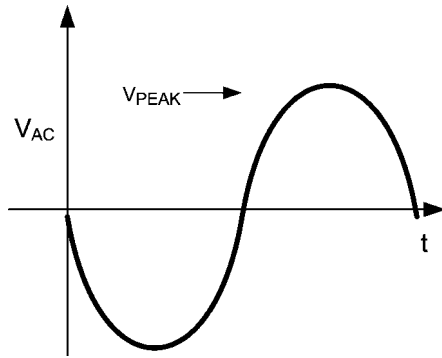

30127554

FIGURE 12. AC Line

Figure 12 shows the AC waveform. One can easily see that the peak voltage ( $V_{PEAK}$ ) will always be:

$$V_{AC-RMS-PK} \sqrt{2}$$

The voltage at  $V_{BUCK}$  with a valley fill stage of two will look similar to the waveforms of Figure 11.

The purpose of the valley fill circuit is to allow the buck converter to pull power directly off of the AC line when the line voltage is greater than its peak voltage divided by two (two stage valley fill circuit). During this time, the capacitors within the valley fill circuit (C7 and C8) are charged up to the peak of the AC line voltage. Once the line drops below its peak divided by two, the two capacitors are placed in parallel and deliver power to the buck converter. One can now see that if the peak of the AC line voltage is lowered due to variations in the line voltage the DC offset ( $V_{DC}$ ) will lower.  $V_{DC}$  is the lowest value that voltage  $V_{BUCK}$  will encounter.

$$V_{BUCK(MIN)} = \frac{V_{AC-RMS(MIN)} \sqrt{2} \times \sin(\theta)}{\#stages}$$

Example:

Line voltage =  $90V_{AC}$  to  $135V_{AC}$

Valley-Fill = two stage

$$V_{BUCK(MIN)} = \frac{90 \sqrt{2} \times \sin(135^\circ)}{2} = 45V$$

Depending on what type and value of capacitors are used, some derating should be used for voltage droop when the capacitors are delivering power to the buck converter. With this derating, the lowest voltage the buck converter will see is about 42.5V in this example.

To determine how many LEDs can be driven, take the minimum voltage the buck converter will see (42.5V) and divide it by the worst case forward voltage drop of a single LED.

Example:  $42.5V/3.7V = 11.5$  LEDs (11 LEDs with margin)

### OUTPUT CAPACITOR

A capacitor placed in parallel with the LED or array of LEDs can be used to reduce the LED current ripple while keeping the same average current through both the inductor and the LED array. With a buck topology the output inductance (L2) can now be lowered, making the magnetics smaller and less expensive. With a well designed converter, you can assume

that all of the ripple will be seen by the capacitor, and not the LEDs. One must ensure that the capacitor you choose can handle the RMS current of the inductor. Refer to manufacturer's datasheets to ensure compliance. Usually an X5R or X7R capacitor between  $1 \mu F$  and  $10 \mu F$  of the proper voltage rating will be sufficient.

### SWITCHING MOSFET

The main switching MOSFET should be chosen with efficiency and robustness in mind. The maximum voltage across the switching MOSFET will equal:

$$V_{DS(MAX)} = V_{AC-RMS(MAX)} \sqrt{2}$$

The average current rating should be greater than:

$$I_{DS-MAX} = I_{LED(AVE)} (D_{MAX})$$

### RE-CIRCULATING DIODE

The LM3444 Buck converter requires a re-circulating diode D10 (see the Typical Application circuit Figure 2) to carry the inductor current during the MOSFET Q2 off-time. The most efficient choice for D10 is a diode with a low forward drop and near-zero reverse recovery time that can withstand a reverse voltage of the maximum voltage seen at  $V_{BUCK}$ . For a common  $110V_{AC} \pm 20\%$  line, the reverse voltage could be as high as 190V.

$$V_D \geq V_{AC-RMS(MAX)} \sqrt{2}$$

The current rating must be at least:

$$I_D = 1 - (D_{MIN}) \times I_{LED(AVE)}$$

Or:

$$I_D = \left( 1 - \frac{V_{LED(MIN)}}{V_{BUCK(MAX)}} \right) \times I_{LED(AVE)}$$

### Design Example

The following design example illustrates the process of calculating external component values.

#### Known:

1. Input voltage range ( $90V_{AC} - 135V_{AC}$ )
2. Number of LEDs in series = 7
3. Forward voltage drop of a single LED = 3.6V
4. LED stack voltage = ( $7 \times 3.6V$ ) = 25.2V

#### Choose:

1. Nominal switching frequency,  $f_{SW-TARGET} = 250$  kHz
2.  $I_{LED(AVE)} = 400$  mA
3.  $\Delta i$  (usually 15% - 30% of  $I_{LED(AVE)}$ ) = ( $0.30 \times 400$  mA) = 120 mA
4. Valley fill stages (1,2, or 3) = 2
5. Assumed minimum efficiency = 80%

#### Calculate:

1. Calculate minimum voltage  $V_{BUCK}$  equals:

$$V_{BUCK(MIN)} = \frac{90 \sqrt{2} \times \sin(135^\circ)}{2} = 45V$$

2. Calculate maximum voltage  $V_{BUCK}$  equals:

$$V_{\text{BUCK(MAX)}} = 135\sqrt{2} = 190\text{V}$$

3. Calculate  $t_{\text{OFF}}$  at  $V_{\text{BUCK}}$  nominal line voltage:

$$t_{\text{OFF}} = \frac{\left(1 - \frac{1}{0.8} \times \frac{25.2\text{V}}{115\sqrt{2}}\right)}{(250 \text{ kHz})} = 3.23 \mu\text{s}$$

4. Calculate  $t_{\text{ON(MIN)}}$  at high line to ensure that  $t_{\text{ON(MIN)}} > 200 \text{ ns}$ :

$$t_{\text{ON(MIN)}} = \frac{\left(\frac{1}{0.8} \times \frac{25.2\text{V}}{135\sqrt{2}}\right)}{\left(1 - \frac{1}{0.8} \times \frac{25.2\text{V}}{135\sqrt{2}}\right)} \times 3.23 \mu\text{s} = 638 \text{ ns}$$

5. Calculate C11 and R4:  
6. Choose current through R4: (between 50  $\mu\text{A}$  and 100  $\mu\text{A}$ )  
70  $\mu\text{A}$

$$R4 = \frac{V_{\text{LED}}}{I_{\text{COLL}}} = 360 \text{ k}\Omega$$

7. Use a standard value of 365  $\text{k}\Omega$

8. Calculate C11:

9.

$$C11 = \left(\frac{V_{\text{LED}}}{R4}\right) \left(\frac{t_{\text{OFF}}}{1.276}\right) = 175 \text{ pF}$$

10. Use standard value of 120 pF  
11. Calculate ripple current: 400 mA X 0.30 = 120 mA  
12. Calculate inductor value at  $t_{\text{OFF}} = 3 \mu\text{s}$ :

$$L2 = \frac{25.2\text{V} \left(1 - \frac{1}{0.8} \times \frac{25.2\text{V}}{115\sqrt{2}}\right)}{(350 \text{ kHz} \times 0.1\text{A})} = 580 \mu\text{H}$$

13. Choose C10: 1.0  $\mu\text{F}$  200V  
14. Calculate valley-fill capacitor values:  $V_{\text{AC}}$  low line = 90V<sub>AC</sub>,  $V_{\text{BUCK}}$  minimum equals 60V. Set droop for 20V maximum at full load and low line.

$$i = C \frac{dv}{dt}$$

i) equals  $P_{\text{OUT}}/V_{\text{BUCK}}$  (270 mA), dV equals 20V, dt equals 2.77 ms, and then  $C_{\text{TOTAL}}$  equals 37  $\mu\text{F}$ . Therefore C7 = C9 = 22  $\mu\text{F}$

# LM3444 Design Example 1

Input = 90V<sub>AC</sub> to 135V<sub>AC</sub>, V<sub>LED</sub> = 7 x HB LED String Application @ 400 mA

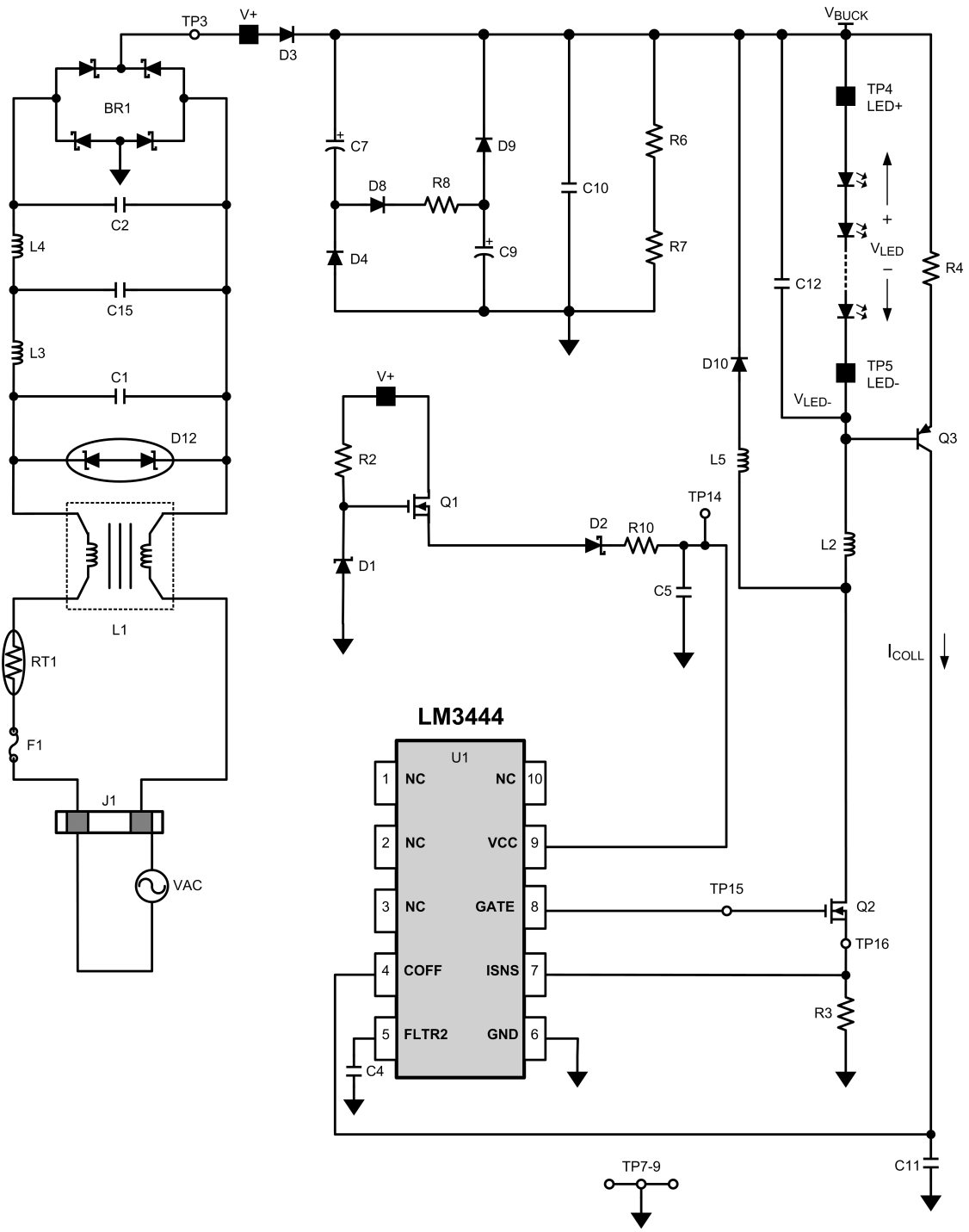

30127569

## Bill of Materials

Qty	Ref Des	Description	Mfr	Mfr PN
1	U1	IC, CTRLR, DRVR-LED, MSOP10	NSC	LM3444MM
1	BR1	Bridge Rectifier, SMT, 400V, 800 mA	DiodesInc	HD04-T
1	L1	Common mode filter DIP4NS, 900 mA, 700 $\mu$ H	Panasonic	ELF-11090E
1	L2	Inductor, SHLD, SMT, 1A, 470 $\mu$ H	Coilcraft	MSS1260-474-KLB
2	L3, L4	Diff mode inductor, 500 mA 1 mH	Coilcraft	MSS1260-105KL-KLB
1	L5	Bead Inductor, 160 $\Omega$ , 6A	Steward	HI1206T161R-10
3	C1, C2, C15	Cap, Film, X2Y2, 12.5MM, 250V <sub>AC</sub> , 20%, 10 nF	Panasonic	ECQ-U2A103ML
1	C4	Cap, X7R, 0603, 16V, 10%, 100 nF	MuRata	GRM188R71C104KA01D
2	C5, C6	Cap, X5R, 1210, 25V, 10%, 22 $\mu$ F	MuRata	GRM32ER61E226KE15L
2	C7, C9	Cap, AL, 200V, 105C, 20%, 33 $\mu$ F	UCC	EKXG201ELL330MK20S
1	C10	Cap, Film, 250V, 5%, 10 nF	Epcos	B32521C3103J
1	C12	Cap, X7R, 1206, 50V, 10%, 1.0 $\mu$ F	Kemet	C1206F105K5RACTU
1	C11	Cap, C0G, 0603, 100V, 5%, 120 pF	MuRata	GRM1885C2A121JA01D
1	D1	Diode, ZNR, SOT23, 15V, 5%	OnSemi	BZX84C15LT1G
2	D2, D13	Diode, SCH, SOD123, 40V, 120 mA	NXP	BAS40H
4	D3, D4, D8, D9	Diode, FR, SOD123, 200V, 1A	Rohm	RF071M2S
1	D10	Diode, FR, SMB, 400V, 1A	OnSemi	MURS140T3G
1	D12	TVS, VBR = 144V	Fairchild	SMBJ130CA
1	R2	Resistor, 1206, 1%, 100 k $\Omega$	Panasonic	ERJ-8ENF1003V
1	R3	Resistor, 1210, 5%, 1.8 $\Omega$	Panasonic	ERJ-14RQJ1R8U
1	R4	Resistor, 0603, 1%, 576 k $\Omega$	Panasonic	ERJ-3EKF5763V
2	R6, R7	Resistor, 0805, 1%, 1.00 M $\Omega$	Rohm	MCR10EZHF1004
2	R8, R10	Resistor, 1206, 0.0 $\Omega$	Yageo	RC1206JR-070RL
1	R9	Resistor, 1812, 0.0 $\Omega$		
1	RT1	Thermistor, 120V, 1.1A, 50 $\Omega$ @ 25°C	Thermometrics	CL-140
2	Q1, Q2	XSTR, NFET, DPAK, 300V, 4A	Fairchild	FQD7N30TF
1	Q3	XSTR, PNP, SOT23, 300V, 500 mA	Fairchild	MMBTA92
1	J1	Terminal Block 2 pos	Phoenix Contact	1715721
1	F1	Fuse, 125V, 1,25A	bel	SSQ 1.25



**Physical Dimensions** inches (millimeters) unless otherwise noted

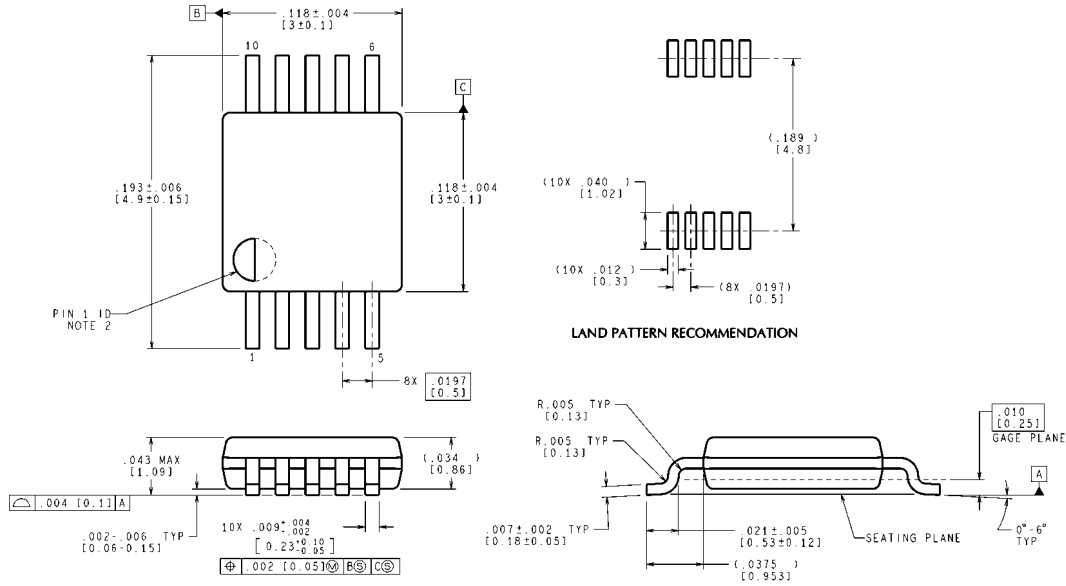

CONTROLLING DIMENSION IS INCH  
 VALUES IN [ ] ARE MILLIMETERS  
 DIMENSIONS IN ( ) FOR REFERENCE ONLY

**MSOP-10 Pin Package (MM)**  
**For Ordering, Refer to Ordering Information Table**  
**NS Package Number MUB10A**

MUB10A (Rev B)

## Notes

For more National Semiconductor product information and proven design tools, visit the following Web sites at:  
[www.national.com](http://www.national.com)

Products		Design Support	
Amplifiers	<a href="http://www.national.com/amplifiers">www.national.com/amplifiers</a>	WEBENCH® Tools	<a href="http://www.national.com/webench">www.national.com/webench</a>
Audio	<a href="http://www.national.com/audio">www.national.com/audio</a>	App Notes	<a href="http://www.national.com/appnotes">www.national.com/appnotes</a>
Clock and Timing	<a href="http://www.national.com/timing">www.national.com/timing</a>	Reference Designs	<a href="http://www.national.com/refdesigns">www.national.com/refdesigns</a>
Data Converters	<a href="http://www.national.com/adc">www.national.com/adc</a>	Samples	<a href="http://www.national.com/samples">www.national.com/samples</a>
Interface	<a href="http://www.national.com/interface">www.national.com/interface</a>	Eval Boards	<a href="http://www.national.com/evalboards">www.national.com/evalboards</a>
LVDS	<a href="http://www.national.com/lvds">www.national.com/lvds</a>	Packaging	<a href="http://www.national.com/packaging">www.national.com/packaging</a>
Power Management	<a href="http://www.national.com/power">www.national.com/power</a>	Green Compliance	<a href="http://www.national.com/quality/green">www.national.com/quality/green</a>
Switching Regulators	<a href="http://www.national.com/switchers">www.national.com/switchers</a>	Distributors	<a href="http://www.national.com/contacts">www.national.com/contacts</a>
LDOs	<a href="http://www.national.com/lido">www.national.com/lido</a>	Quality and Reliability	<a href="http://www.national.com/quality">www.national.com/quality</a>
LED Lighting	<a href="http://www.national.com/led">www.national.com/led</a>	Feedback/Support	<a href="http://www.national.com/feedback">www.national.com/feedback</a>
Voltage References	<a href="http://www.national.com/vref">www.national.com/vref</a>	Design Made Easy	<a href="http://www.national.com/easy">www.national.com/easy</a>
PowerWise® Solutions	<a href="http://www.national.com/powerwise">www.national.com/powerwise</a>	Applications & Markets	<a href="http://www.national.com/solutions">www.national.com/solutions</a>
Serial Digital Interface (SDI)	<a href="http://www.national.com/sdi">www.national.com/sdi</a>	Mil/Aero	<a href="http://www.national.com/milaero">www.national.com/milaero</a>
Temperature Sensors	<a href="http://www.national.com/tempensors">www.national.com/tempensors</a>	SolarMagic™	<a href="http://www.national.com/solarmagic">www.national.com/solarmagic</a>
PLL/VCO	<a href="http://www.national.com/wireless">www.national.com/wireless</a>	PowerWise® Design University	<a href="http://www.national.com/training">www.national.com/training</a>

THE CONTENTS OF THIS DOCUMENT ARE PROVIDED IN CONNECTION WITH NATIONAL SEMICONDUCTOR CORPORATION ("NATIONAL") PRODUCTS. NATIONAL MAKES NO REPRESENTATIONS OR WARRANTIES WITH RESPECT TO THE ACCURACY OR COMPLETENESS OF THE CONTENTS OF THIS PUBLICATION AND RESERVES THE RIGHT TO MAKE CHANGES TO SPECIFICATIONS AND PRODUCT DESCRIPTIONS AT ANY TIME WITHOUT NOTICE. NO LICENSE, WHETHER EXPRESS, IMPLIED, ARISING BY ESTOPPEL OR OTHERWISE, TO ANY INTELLECTUAL PROPERTY RIGHTS IS GRANTED BY THIS DOCUMENT.

TESTING AND OTHER QUALITY CONTROLS ARE USED TO THE EXTENT NATIONAL DEEMS NECESSARY TO SUPPORT NATIONAL'S PRODUCT WARRANTY. EXCEPT WHERE MANDATED BY GOVERNMENT REQUIREMENTS, TESTING OF ALL PARAMETERS OF EACH PRODUCT IS NOT NECESSARILY PERFORMED. NATIONAL ASSUMES NO LIABILITY FOR APPLICATIONS ASSISTANCE OR BUYER PRODUCT DESIGN. BUYERS ARE RESPONSIBLE FOR THEIR PRODUCTS AND APPLICATIONS USING NATIONAL COMPONENTS. PRIOR TO USING OR DISTRIBUTING ANY PRODUCTS THAT INCLUDE NATIONAL COMPONENTS, BUYERS SHOULD PROVIDE ADEQUATE DESIGN, TESTING AND OPERATING SAFEGUARDS.

EXCEPT AS PROVIDED IN NATIONAL'S TERMS AND CONDITIONS OF SALE FOR SUCH PRODUCTS, NATIONAL ASSUMES NO LIABILITY WHATSOEVER, AND NATIONAL DISCLAIMS ANY EXPRESS OR IMPLIED WARRANTY RELATING TO THE SALE AND/OR USE OF NATIONAL PRODUCTS INCLUDING LIABILITY OR WARRANTIES RELATING TO FITNESS FOR A PARTICULAR PURPOSE, MERCHANTABILITY, OR INFRINGEMENT OF ANY PATENT, COPYRIGHT OR OTHER INTELLECTUAL PROPERTY RIGHT.

#### LIFE SUPPORT POLICY

**NATIONAL'S PRODUCTS ARE NOT AUTHORIZED FOR USE AS CRITICAL COMPONENTS IN LIFE SUPPORT DEVICES OR SYSTEMS WITHOUT THE EXPRESS PRIOR WRITTEN APPROVAL OF THE CHIEF EXECUTIVE OFFICER AND GENERAL COUNSEL OF NATIONAL SEMICONDUCTOR CORPORATION.** As used herein:

Life support devices or systems are devices which (a) are intended for surgical implant into the body, or (b) support or sustain life and whose failure to perform when properly used in accordance with instructions for use provided in the labeling can be reasonably expected to result in a significant injury to the user. A critical component is any component in a life support device or system whose failure to perform can be reasonably expected to cause the failure of the life support device or system or to affect its safety or effectiveness.

National Semiconductor and the National Semiconductor logo are registered trademarks of National Semiconductor Corporation. All other brand or product names may be trademarks or registered trademarks of their respective holders.

Copyright© 2011 National Semiconductor Corporation

For the most current product information visit us at [www.national.com](http://www.national.com)



**National Semiconductor  
Americas Technical  
Support Center**  
Email: [support@nsc.com](mailto:support@nsc.com)  
Tel: 1-800-272-9959

**National Semiconductor Europe  
Technical Support Center**  
Email: [europe.support@nsc.com](mailto:europe.support@nsc.com)

**National Semiconductor Asia  
Pacific Technical Support Center**  
Email: [ap.support@nsc.com](mailto:ap.support@nsc.com)

**National Semiconductor Japan  
Technical Support Center**  
Email: [jpn.feedback@nsc.com](mailto:jpn.feedback@nsc.com)