

FEATURES

1Mb Serial SPI MRAM

- No write delays
- Unlimited write endurance
- Data retention greater than 20 years
- Automatic data protection on power loss
- Fast, simple SPI interface with up to 40 MHz clock rate
- 2.7 to 3.6 Volt power supply range
- 3 μ A sleep mode standby current
- Industrial, automotive temperatures
- Small footprint 8-pin DFN RoHS-compliant package
- Direct replacement for serial EEPROM, Flash, FeRAM



INTRODUCTION



The **MR25H10** is a 1,048,576-bit magnetoresistive random access memory (MRAM) device organized as 131,072 words of 8 bits. The **MR25H10** offers serial EEPROM and serial Flash compatible read/write timing with no write delays and unlimited read/write endurance.

Unlike other serial memories, both reads and writes can occur randomly in memory with no delay between writes. The **MR25H10** is the ideal memory solution for applications that must store and retrieve data and programs quickly using a small number of I/O pins

The **MR25H10** is available in a small footprint 5 mm x 6 mm 8-pin DFN package that is compatible with serial EEPROM, Flash, and FeRAM products.

The **MR25H10** provides highly reliable data storage over a wide range of temperatures. The product is offered with industrial temperature (-40° to +85 °C), and automotive temperature (-40° to +125° C) range options.

CONTENTS

1. DEVICE PIN ASSIGNMENT.....	2
2. SPI COMMUNICATIONS PROTOCOL.....	4
3. ELECTRICAL SPECIFICATIONS.....	10
4. TIMING SPECIFICATIONS.....	12
5. ORDERING INFORMATION.....	12
6. MECHANICAL DRAWING.....	13
7. REVISION HISTORY.....	15
How to Reach Us.....	15

1. DEVICE PIN ASSIGNMENT

Overview

The MR25H10 is a serial MRAM with memory array logically organized as 128Kx8 using the four pin interface of chip select (\overline{CS}), serial input (SI), serial output (SO) and serial clock (SCK) of the serial peripheral interface (SPI) bus. Serial MRAM implements a subset of commands common to today's SPI EEPROM and Flash components allowing MRAM to replace these components in the same socket and interoperate on a shared SPI bus. Serial MRAM offers superior write speed, unlimited endurance, low standby & operating power, and more reliable data retention compared to available serial memory alternatives.

Figure 1.1 Block Diagram

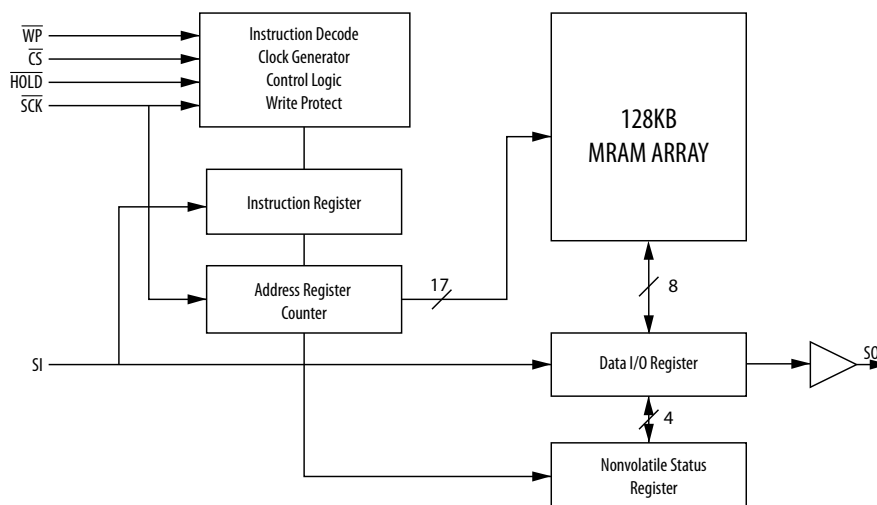

System Configuration

Single or multiple devices can be connected to the bus as show in Figure 1.2. Pins SCK, SO and SI are common among devices. Each device requires \overline{CS} and \overline{HOLD} pins to be driven seperately.

Figure 1.2 System Configuration

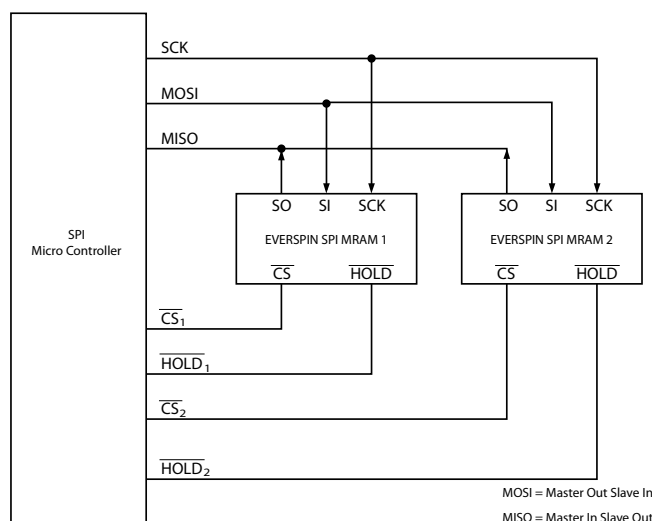
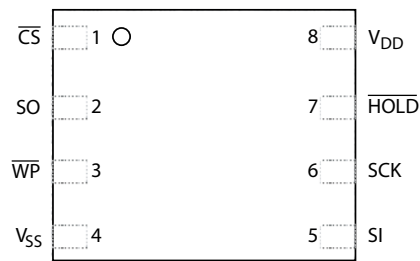

Figure 1.3 Pin Diagrams (Top View)



8-Pin DFN

Table 1.1 Pin Functions

Signal Name	Pin	I/O	Function	Description
\overline{CS}	1	Input	Chip Select	An active low chip select for the serial MRAM. When chip select is high, the memory is powered down to minimize standby power, inputs are ignored and the serial output pin is Hi-Z. Multiple serial memories can share a common set of data pins by using a unique chip select for each memory.
SO	2	Output	Serial Output	The data output pin is driven during a read operation and remains Hi-Z at all other times. SO is Hi-Z when HOLD is low. Data transitions on the data output occur on the falling edge of SCK.
\overline{WP}	3	Input	Hold	A low on the write protect input prevents write operations to the Status Register.
V_{SS}	4	Supply	Ground	Power supply ground pin.
SI	5	Input	Serial Input	All data is input to the device through this pin. This pin is sampled on the rising edge of SCK and ignored at other times. SI can be tied to SO to create a single bidirectional data bus if desired.
SCK	6	Input	Serial Clock	Synchronizes the operation of the MRAM. The clock can operate up to 40 MHz to shift commands, address, and data into the memory. Inputs are captured on the rising edge of clock. Data outputs from the MRAM occur on the falling edge of clock. The serial MRAM supports both SPI Mode 0 (CPOL=0, CPHA=0) and Mode 3 (CPOL=1, CPHA=0). In Mode 0, the clock is normally low. In Mode 3, the clock is normally high. Memory operation is static so the clock can be stopped at any time.
HOLD	7	Input	Hold	A low on the Hold pin interrupts a memory operation for another task. When HOLD is low, the current operation is suspended. The device will ignore transitions on the \overline{CS} and SCK when HOLD is low. All transitions of HOLD must occur while \overline{CS} is low.
V_{DD}	8	Supply	Power Supply	Power supply voltage from +2.7 to +3.6 volts.

2. SPI COMMUNICATIONS PROTOCOL

MR25H10 can be operated in either SPI Mode 0 (CPOL=0, CPHA =0) or SPI Mode 3 (CPOL=1, CPHA=1). For both modes, inputs are captured on the rising edge of the clock and data outputs occur on the falling edge of the clock. When not conveying data, SCK remains low for Mode 0; while in Mode 3, SCK is high. The memory determines the mode of operation (Mode 0 or Mode 3) based upon the state of the SCK when \overline{CS} falls.

All memory transactions start when \overline{CS} is brought low to the memory. The first byte is a command code. Depending upon the command, subsequent bytes of address are input. Data is either input or output. There is only one command performed per \overline{CS} active period. \overline{CS} must go inactive before another command can be accepted. To ensure proper part operation according to specifications, it is necessary to terminate each access by raising \overline{CS} at the end of a byte (a multiple of 8 clock cycles from \overline{CS} dropping) to avoid partial or aborted accesses.

Table 2.1 Command Codes

Instruction	Description	Binary Code	Hex Code	Address Bytes	Data Bytes
WREN	Write Enable	0000 0110	06h	0	0
WRDI	Write Disable	0000 0100	04h	0	0
RDSR	Read Status Register	0000 0101	05h	0	1
WRSR	Write Status Register	0000 0001	01h	0	1
READ	Read Data Bytes	0000 0011	03h	3	1 to ∞
WRITE	Write Data Bytes	0000 0010	02h	3	1 to ∞
SLEEP	Enter Sleep Mode	1011 1001	B9h	0	0
WAKE	Exit Sleep Mode	1010 1011	ABh	0	0

Status Register

The status register consists of the 8 bits listed in table 2.1. As seen in table 2.2, the Status Register Write Disable bit (SRWD) is used in conjunction with bit 1 (WEL) and the Write Protection pin (\overline{WP}) to provide hardware memory block protection. Bits BP0 and BP1 define the memory block arrays that are protected as described in table 2.3. The fast writing speed of MR25H10 does not require write status bits. The state of bits 6,5,4, and 0 can be user modified and do not affect memory operation. All bits in the status register are pre-set from the factory in the "0" state.

Table 2.2 Status Register Bit Assignments

Bit 7	Bit 6	Bit 5	Bit 4	Bit 3	Bit 2	Bit 1	Bit 0
SRWD	Don't Care	Don't Care	Don't Care	BP1	BP0	WEL	Don't Care

Table 2.3 Memory Protection Modes

WEL	SRWD	\overline{WP}	Protected Blocks	Unprotected Blocks	Status Register
0	X	X	Protected	Protected	Protected
1	0	X	Protected	Writable	Writable
1	1	Low	Protected	Writable	Protected
1	1	High	Protected	Writable	Writable

Table 2.4 Block Memory Write Protection

Status Register		Memory Contents	
BP1	BP0	Protected Area	Unprotected Area
0	0	None	All Memory
0	1	Upper Quarter	Lower Three-Quarters
1	0	Upper Half	Lower Half
1	1	All	None

Block Protection

The memory enters hardware block protection when the \overline{WP} input is low and the Status Register Write Disable (\overline{SRWD}) bit is set to 0. The memory leaves hardware block protection only when the \overline{WP} pin goes high. While \overline{WP} is low, the write protection blocks for the memory are determined by the status register bits BP0 and BP1 and cannot be modified without taking the \overline{WP} signal high again.

If the \overline{WP} signal is high (independent of the status of \overline{SRWD} bit), the memory is in software protection mode. This means that block write protection is controlled solely by the status register BP0 and BP1 block write protect bits and this information can be modified using the WRSR command.

Read Status Register (RDSR)

The Read Status Register (RDSR) command allows the Status Register to be read. The Status Register can be read at any time to check the status of write enable latch bit, status register write protect bit, and block write protect bits. For MR25H10, the write in progress bit (bit 0) is not written by the memory because there is no write delay. The RDSR command is entered by driving \overline{CS} low, sending the command code, and then driving \overline{CS} high.

Figure 2.1 RDSR

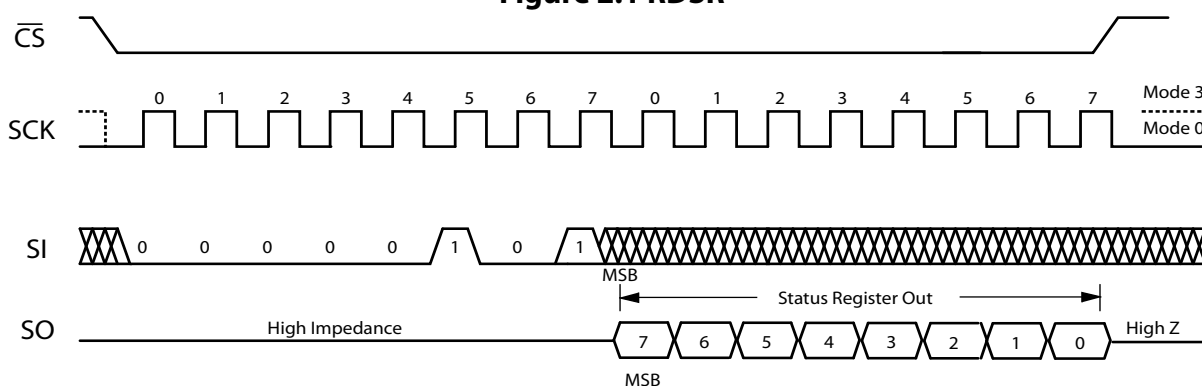

Write Enable (WREN)

The Write Enable (WREN) command sets the Write Enable Latch (WEL) bit in the status register (bit 1). The Write Enable Latch must be set prior to writing either bit in the status register or the memory. The WREN command is entered by driving \overline{CS} low, sending the command code, and then driving \overline{CS} high.

Figure 2.2 WREN

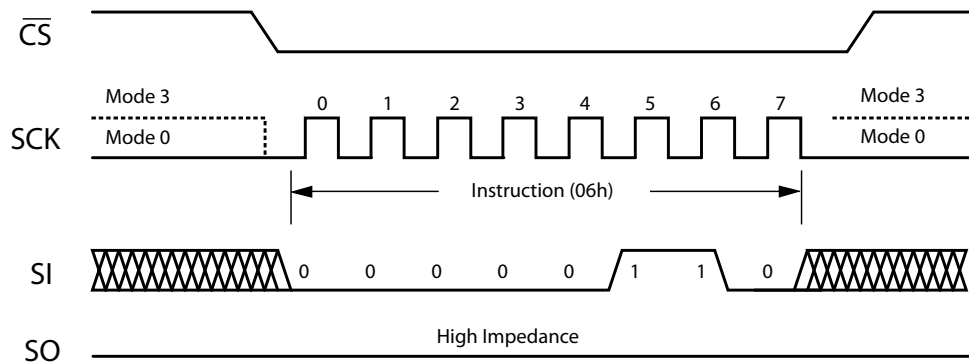

Write Disable (WRDI)

The Write Disable (WRDI) command resets the Write Enable Latch (WEL) bit in the status register (bit 7). This prevents writes to status register or memory. The WRDI command is entered by driving \overline{CS} low, sending the command code, and then driving \overline{CS} high.

The Write Enable Latch (WEL) is reset on power-up or when the WRDI command is completed.

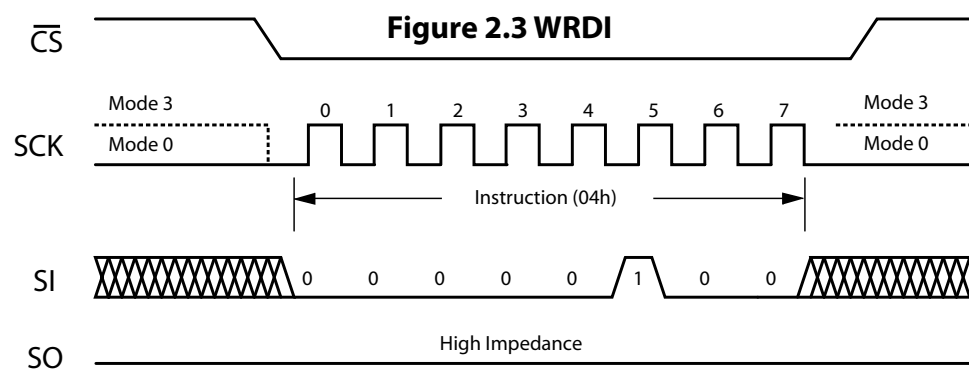

Write Status Register (WRSR)

The Write Status Register (WRSR) command allows new values to be written to the Status Register. The WRSR command is not executed unless the Write Enable Latch (WEL) has been set to 0 by executing a WREN command while pin \overline{WP} and bit SRWD correspond to values that make the status register writable as seen in table 2.2. Status Register bits are non-volatile when the Write Status Register (WRSR) command is issued immediately following a fresh power-up and WREN command. If the WRSR command is issued in a different sequence, i.e. not immediately following power-up and WREN, then upon power cycling the state of the status register bits must be reset before any other part operation.

The WRSR command is entered by driving \overline{CS} low, sending the command code and status register write data byte, and then driving \overline{CS} high.

Figure 2.4 WRSR

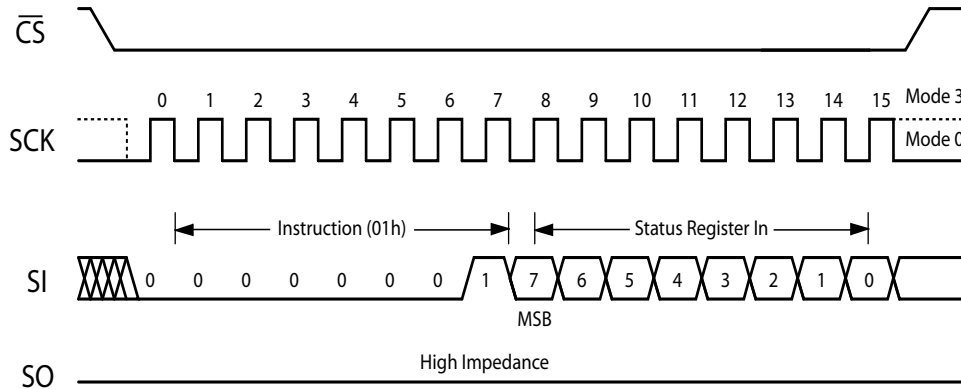

Read Data Bytes (READ)

The Read Data Bytes (READ) command allows data bytes to be read starting at an address specified by the 24-bit address. Only address bits 0-16 are decoded by the memory. The data bytes are read out sequentially from memory until the read operation is terminated by bringing \overline{CS} high. The entire memory can be read in a single command. The address counter will roll over to 0000h when the address reaches the top of memory.

The READ command is entered by driving \overline{CS} low and sending the command code. The memory drives the read data bytes on the SO pin. Reads continue as long as the memory is clocked. The command is terminated by bring \overline{CS} high.

Figure 2.5 READ

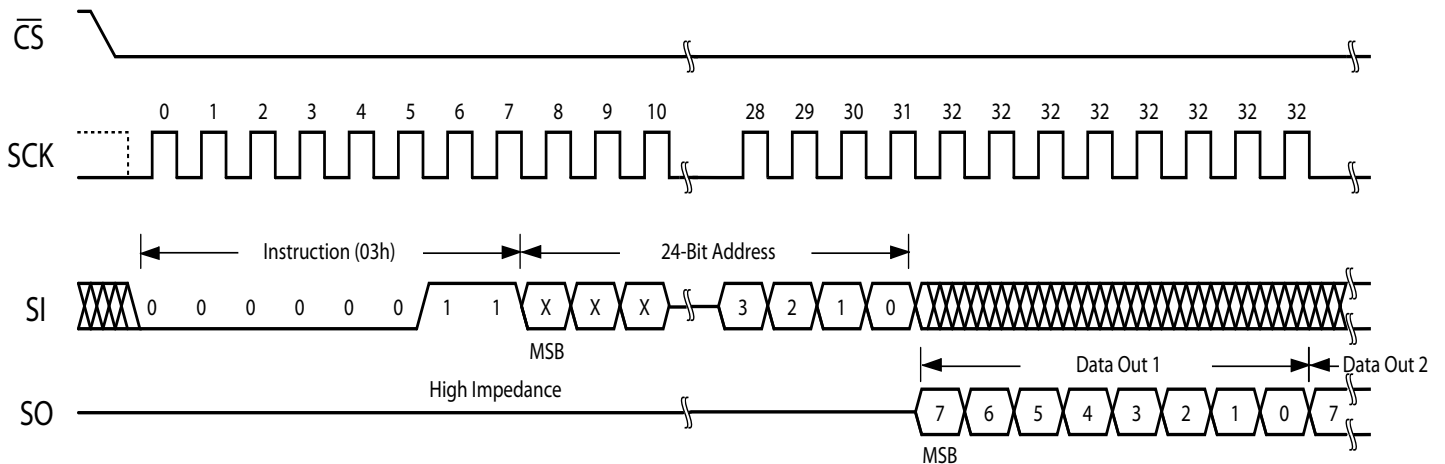

Write Data Bytes (WRITE)

The Write Data Bytes (WRITE) command allows data bytes to be written starting at an address specified by the 24-bit address. Only address bits 0-16 are decoded by the memory. The data bytes are written sequentially in memory until the write operation is terminated by bringing \overline{CS} high. The entire memory can be written in a single command. The address counter will roll over to 0000h when the address reaches the top of memory.

Unlike EEPROM or Flash Memory, MRAM can write data bytes continuously at its maximum rated clock speed without write delays or data polling. Back to back WRITE commands to any random location in memory can be executed without write delay. MRAM is a random access memory rather than a page, sector, or block organized memory so it is ideal for both program and data storage.

The WRITE command is entered by driving \overline{CS} low, sending the command code, and then sequential write data bytes. Writes continue as long as the memory is clocked. The command is terminated by bringing \overline{CS} high.

Figure 2.6 WRITE

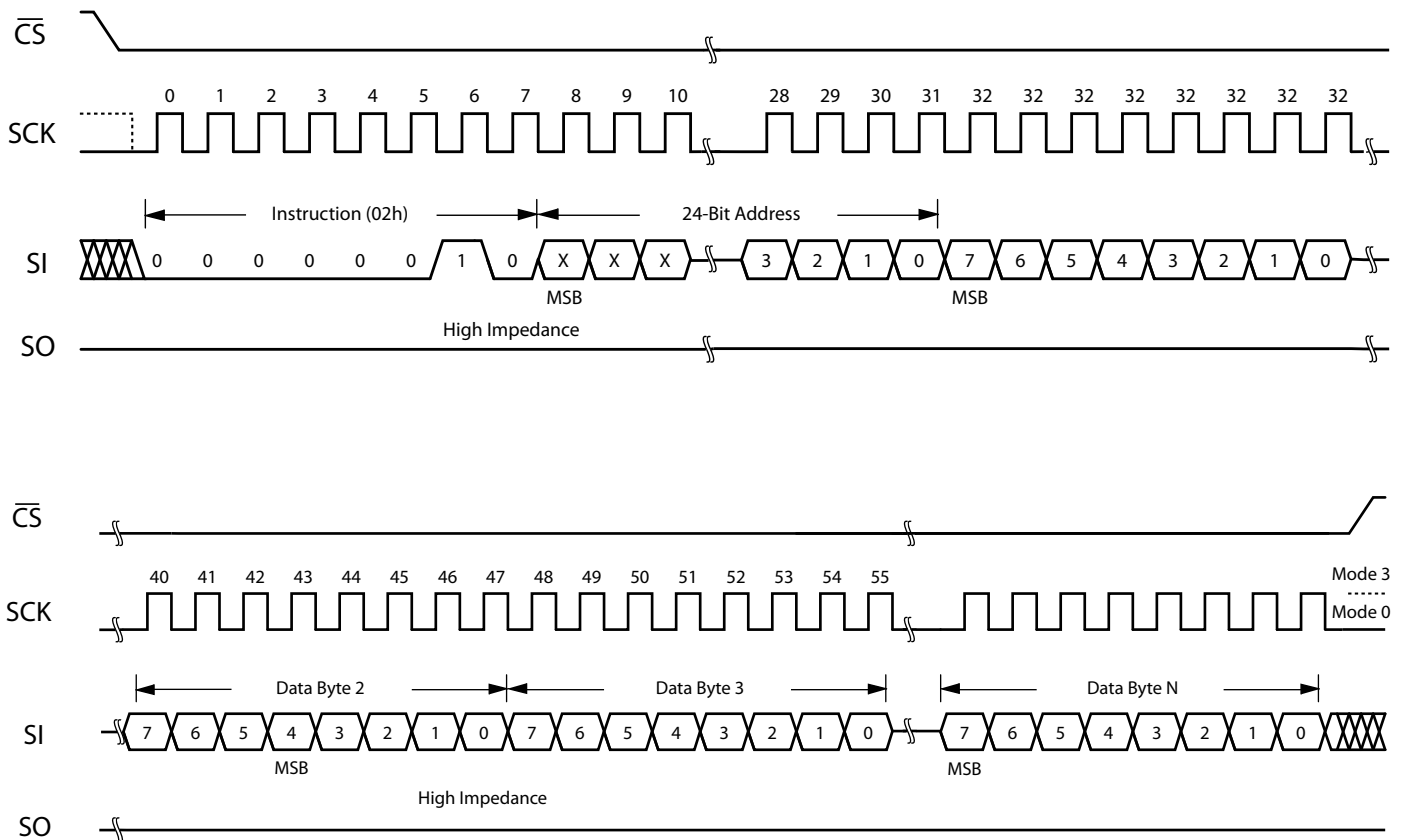

Enter Sleep Mode (SLEEP)

The Enter Sleep Mode (SLEEP) command turns off all MRAM power regulators in order to reduce the overall chip standby power to 3 μ A typical. The SLEEP command is entered by driving \overline{CS} low, sending the command code, and then driving \overline{CS} high. The standby current is achieved after time, t_{DP} .

Figure 2.7 SLEEP

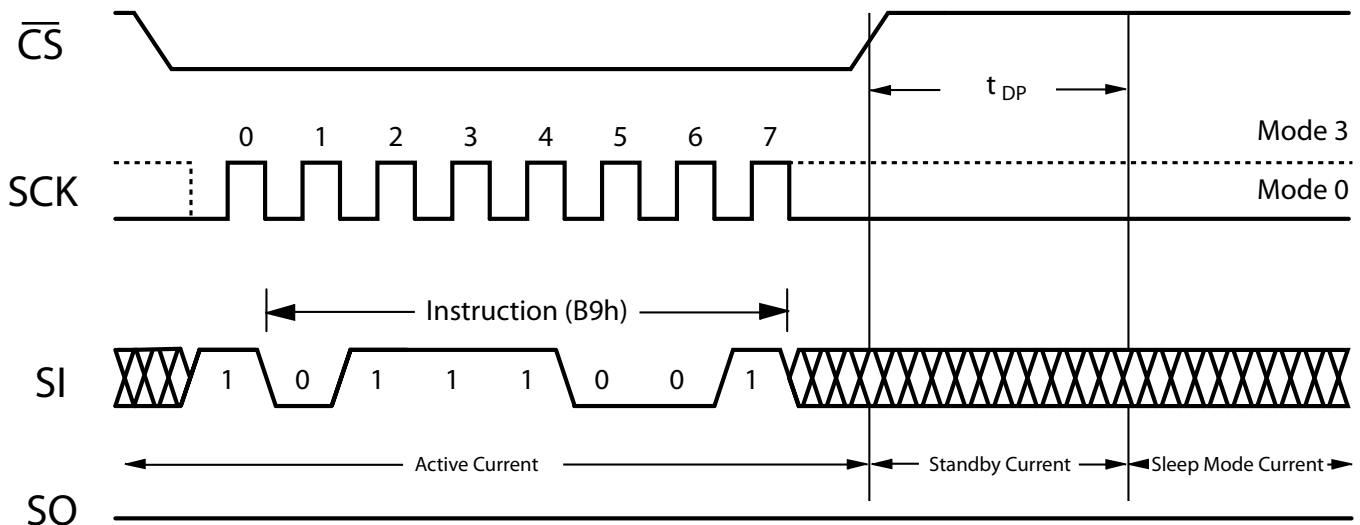

Exit Sleep Mode (WAKE)

The Exit Sleep Mode (WAKE) command turns on internal MRAM power regulators to allow normal operation. The WAKE command is entered by driving \overline{CS} low, sending the command code, and then driving \overline{CS} high. The memory returns to standby mode after t_{RDP} . The \overline{CS} pin must remain high until the t_{RDP} period is over.

Figure 2.8 WAKE

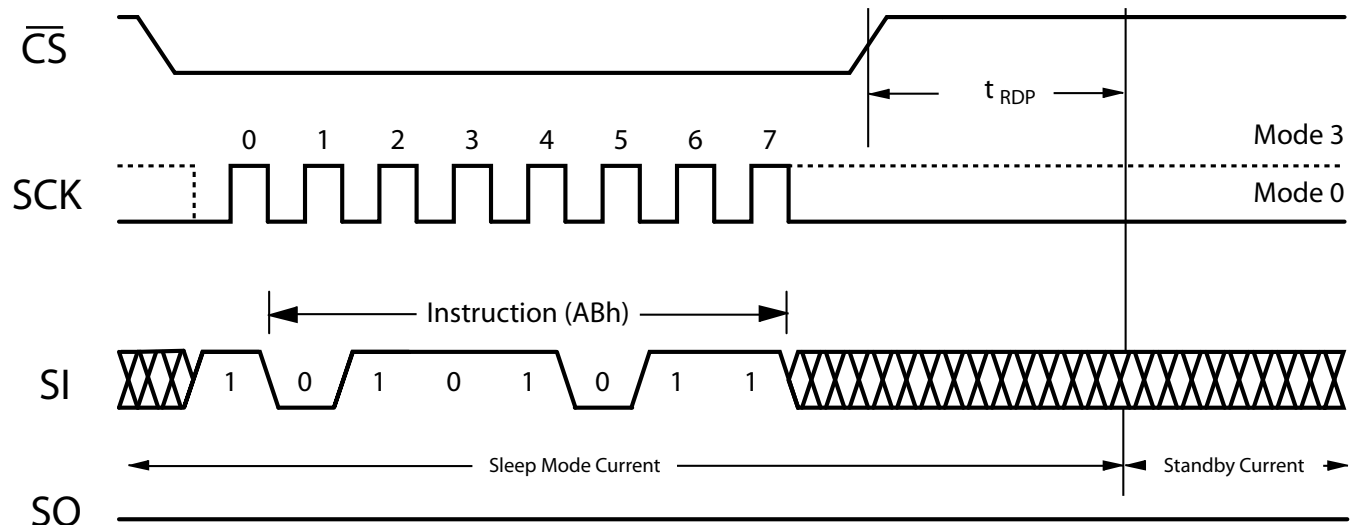

3. ELECTRICAL SPECIFICATIONS

Absolute Maximum Ratings

This device contains circuitry to protect the inputs against damage caused by high static voltages or electric fields; however, it is advised that normal precautions be taken to avoid application of any voltage greater than maximum rated voltages to these high-impedance (Hi-Z) circuits.

The device also contains protection against external magnetic fields. Precautions should be taken to avoid application of any magnetic field more intense than the field intensity specified in the maximum ratings.

Table 3.1 Absolute Maximum Ratings¹

Parameter	Symbol	Value	Unit
Supply voltage ²	V_{DD}	-0.5 to 4.0	V
Voltage on any pin ²	V_{IN}	-0.5 to $V_{DD} + 0.5$	V
Output current per pin	I_{OUT}	± 20	mA
Package power dissipation	P_D	0.600	W
Temperature under bias MR25H10C (Industrial) MR25H10M (Automotive) ⁴	T_{BIAS}	-45 to 95 -45 to 130	°C
Storage Temperature	T_{stg}	-55 to 150	°C
Lead temperature during solder (3 minute max)	T_{Lead}	260	°C
Maximum magnetic field during write	H_{max_write}	12,000	A/m
Maximum magnetic field during read or standby	H_{max_read}	12,000	A/m

¹ Permanent device damage may occur if absolute maximum ratings are exceeded. Functional operation should be restricted to recommended operating conditions. Exposure to excessive voltages or magnetic fields could affect device reliability.

² All voltages are referenced to V_{SS} . The DC value of V_{IN} must not exceed actual applied V_{DD} by more than 0.5V. The AC value of V_{IN} must not exceed applied V_{DD} by more than 2V for 10ns with I_{IN} limited to less than 20mA.

³ Power dissipation capability depends on package characteristics and use environment.

⁴ Automotive temperature profile assumes 10% duty cycle at maximum temperature (2-years out of 20-year life).

Table 3.2 Operating Conditions

Parameter	Symbol	Min	Typical	Max	Unit
Power supply voltage	V_{DD}	2.7		3.6	V
Input high voltage	V_{IH}	2.2	-	$V_{DD} + 0.3$	V
Input low voltage	V_{IL}	-0.5	-	0.8	V
Temperature under bias MR25H10C (Industrial) MR25H10M (Automotive)	T_A	-40 -40	-	85 125	°C

Table 3.3 DC Characteristics

Parameter	Symbol	Min	Typical	Max	Unit
Input leakage current	I_{LI}	-	-	± 1	μA
Output leakage current	I_{LO}	-	-	± 1	μA
Output low voltage ($I_{OL} = +4 \text{ mA}$) ($I_{OL} = +100 \mu A$)	V_{OL}	-	-	0.4 $V_{DD} + 0.2$	V
Output high voltage ($I_{OH} = -4 \text{ mA}$) ($I_{OH} = -100 \mu A$)	V_{OH}	2.4 $V_{DD} - 0.2$	-	-	V

Table 3.4 Power Supply Characteristics

Parameter	Symbol	Typical	Max	Unit
Active Read Current (@ 1 MHz)	I_{DDR}	2.5	TBD	mA
Active Read Current (@ 40 MHz)	I_{DDR}	10	TBD	mA
Active Write Current (@ 1 MHz)	I_{DDW}	6.5	TBD	mA
Active Write Current (@ 40 MHz)	I_{DDW}	12	TBD	mA
Standby Current (\overline{CS} High)	I_{SB1}	90	TBD	μA
Standby Sleep Mode Current (\overline{CS} High) ¹	I_{SB2}	3	10	μA

¹ Automotive I_{SB2} TBD.

4. TIMING SPECIFICATIONS

Table 4.1 Capacitance¹

Parameter	Symbol	Typical	Max	Unit
Control input capacitance	C_{In}	-	6	pF
Input/Output capacitance	$C_{I/O}$	-	8	pF

¹ $f = 1.0$ MHz, $dV = 3.0$ V, $T_A = 25$ °C, periodically sampled rather than 100% tested.

Table 4.2 AC Measurement Conditions

Parameter	Value	Unit
Logic input timing measurement reference level	1.5	V
Logic output timing measurement reference level	1.5	V
Logic input pulse levels	0 or 3.0	V
Input rise/fall time	2	ns
Output load for low and high impedance parameters	See Figure 4.1	
Output load for all other timing parameters	See Figure 4.2	

Figure 4.1 Output Load for Impedance Parameter Measurements

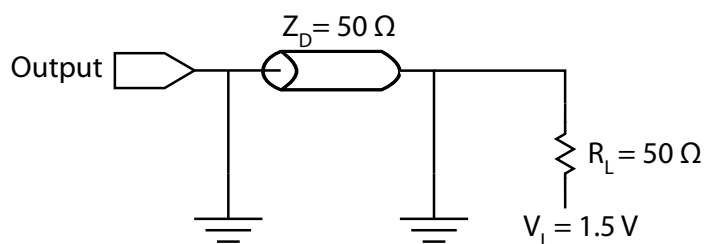
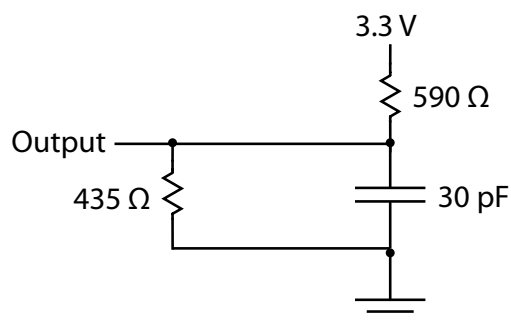

Figure 4.2 Output Load for all Other Parameter Measurements



Power-Up Timing

The MR25H10 is not accessible for a start-up time, $t_{PU} = 400 \mu s$ after power up. Users must wait this time from the time when $V_{DD}(\min)$ is reached until the first \overline{CS} low to allow internal voltage references to become stable. The \overline{CS} signal should be pulled up to V_{DD} so that the signal tracks the power supply during power-up sequence.

Table 4.3 Power-Up

Parameter	Symbol	Min	Typical	Max	Unit
Write Inhibit Voltage	V_{WI}	2.2	-	2.7	V
Startup Time	t_{PU}	400	-	-	μs

Figure 4.3 Power-Up Timing

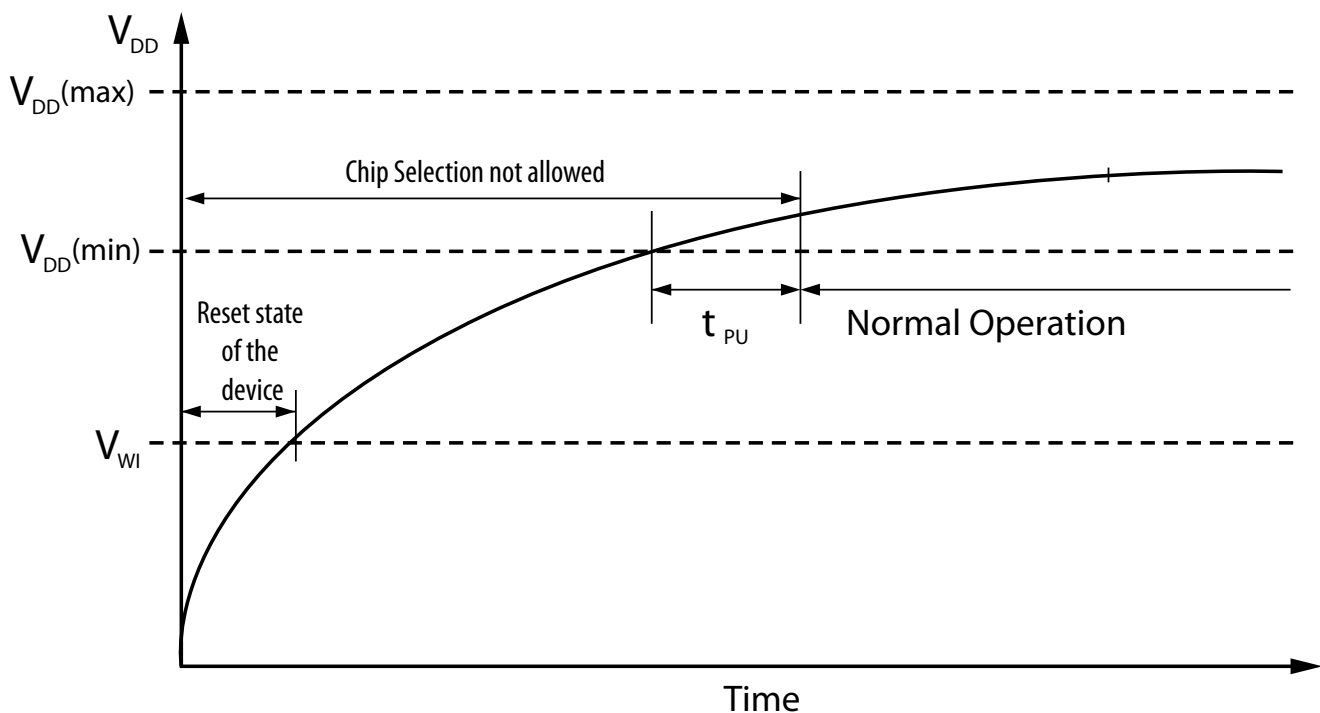

Synchronous Data Timing

Table 4.4 AC Timing Parameters¹

Parameter	Symbol	Min	Typical	Max	Unit
SCK Clock Frequency	f_{SCK}	0	-	40	MHz
Input Rise Time	t_{RI}	-	-	50	ns
Input Fall Time	t_{RF}	-	-	50	ns
SCK High Time	t_{WH}	11	-	-	ns
SCK Low Time	t_{WL}	11	-	-	ns
Synchronous Data Timing (See figure 4.4)					
\overline{CS} High Time	t_{CS}	40	-	-	ns
\overline{CS} Setup Time	t_{CSS}	10	-	-	ns
\overline{CS} Hold Time	t_{CSH}	10	-	-	ns
Data In Setup Time	t_{SU}	5	-	-	ns
Data In Hold Time	t_H	5	-	-	ns
Output Valid ²	t_V	0	-	9	ns
Output Hold Time	t_{HO}	0	-	-	ns
\overline{HOLD} Timing (See figure 4.5)					
\overline{HOLD} Setup Time	t_{HD}	10	-	-	ns
\overline{HOLD} Hold Time	t_{CD}	10	-	-	ns
\overline{HOLD} to Output Low Impedance	t_{LZ}	-	-	20	ns
\overline{HOLD} to Output High Impedance	t_{HZ}	-	-	20	ns
Other Timing Specifications					
\overline{WP} Setup To \overline{CS}	t_{WPS}	5	-	-	ns
\overline{WP} Hold From \overline{CS}	t_{WPH}	5	-	-	ns
Sleep Mode Entry Time	t_{DP}	3	-	-	μ s
Sleep Mode Exit Time	t_{RDP}	400	-	-	μ s
Output Disable Time	t_{DIS}	12	-	-	ns

¹ Operating Temperature Range, $V_{DD}=2.7$ to 3.6 V, $C_L=30$ pF

² Automotive t_V is TBD.

Figure 4.4 Synchronous Data Timing

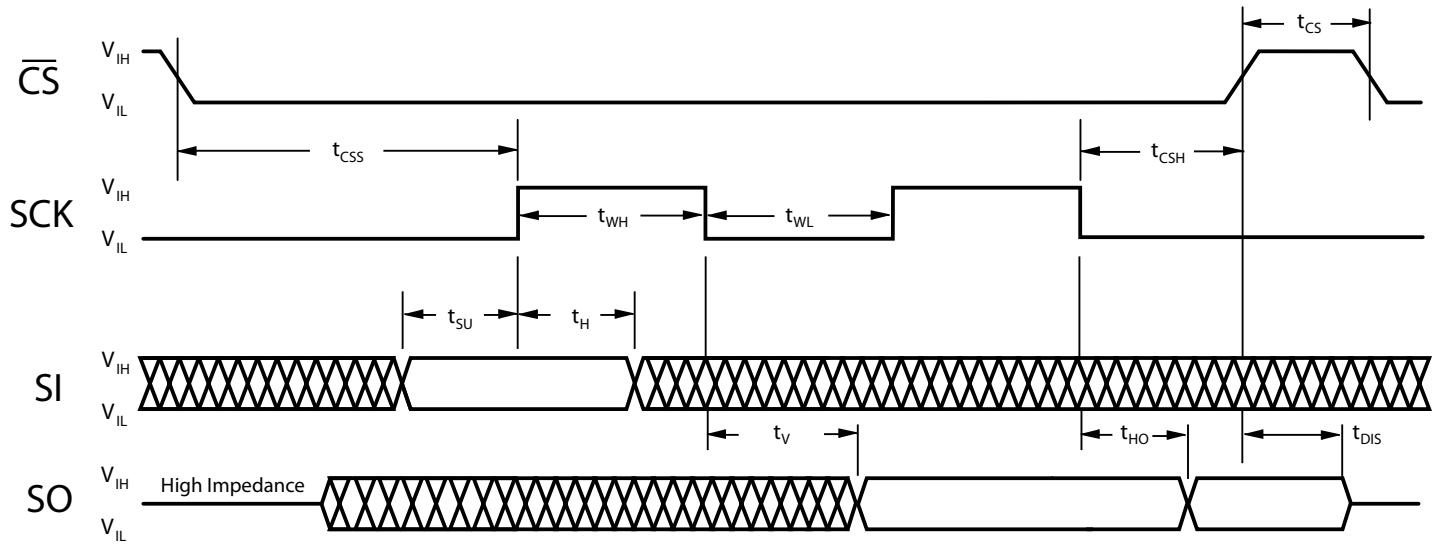
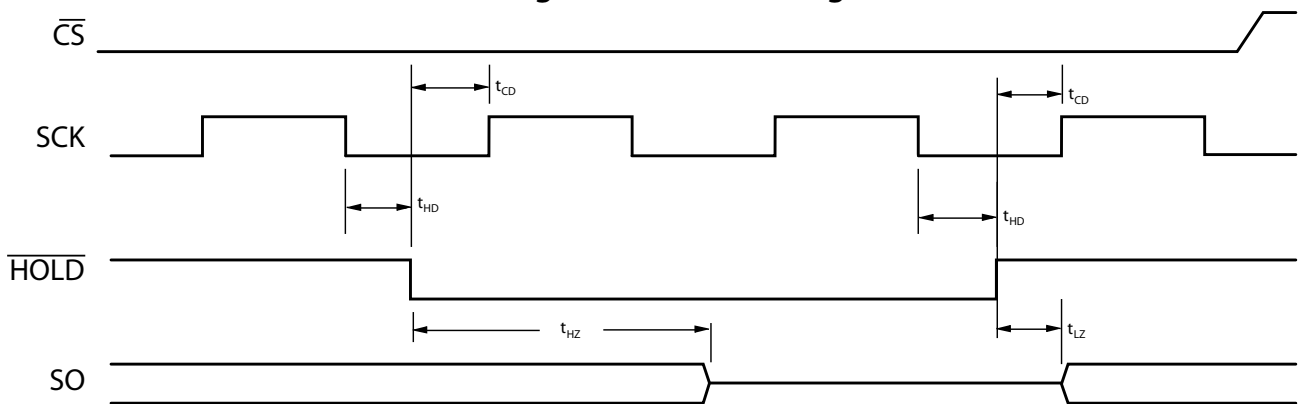

Figure 4.5 HOLD Timing



5. ORDERING INFORMATION

Figure 4.1 Part Numbering System

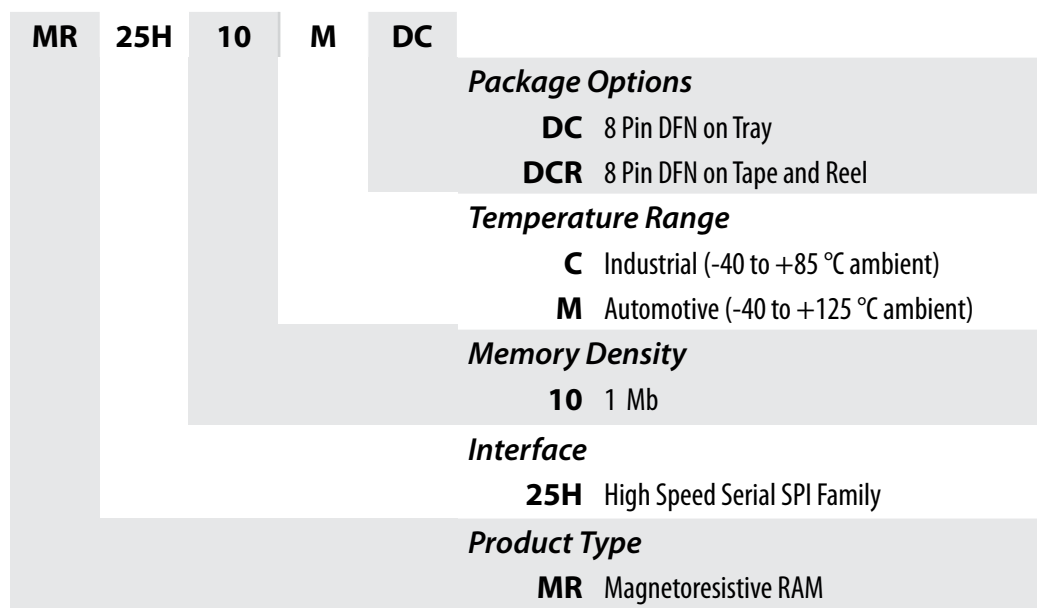

Table 4.1 Available Parts

Part Number	Description	Temperature
MR25H10CDC	3 V 1Mb Serial MRAM 8-DFN	Industrial
MR25H10MDC	3 V 1Mb Serial MRAM 8-DFN	Automotive
MR25H10CDCR	3 V 1Mb Serial MRAM 8-DFN Tape and Reel	Industrial
MR25H10MDCR	3 V 1Mb Serial MRAM 8-DFN Tape and Reel	Automotive

Preliminary - This is a product in development that has fixed target specifications that are subject to change pending characterization results.

6. MECHANICAL DRAWINGS

Figure 6.1 DFN Package

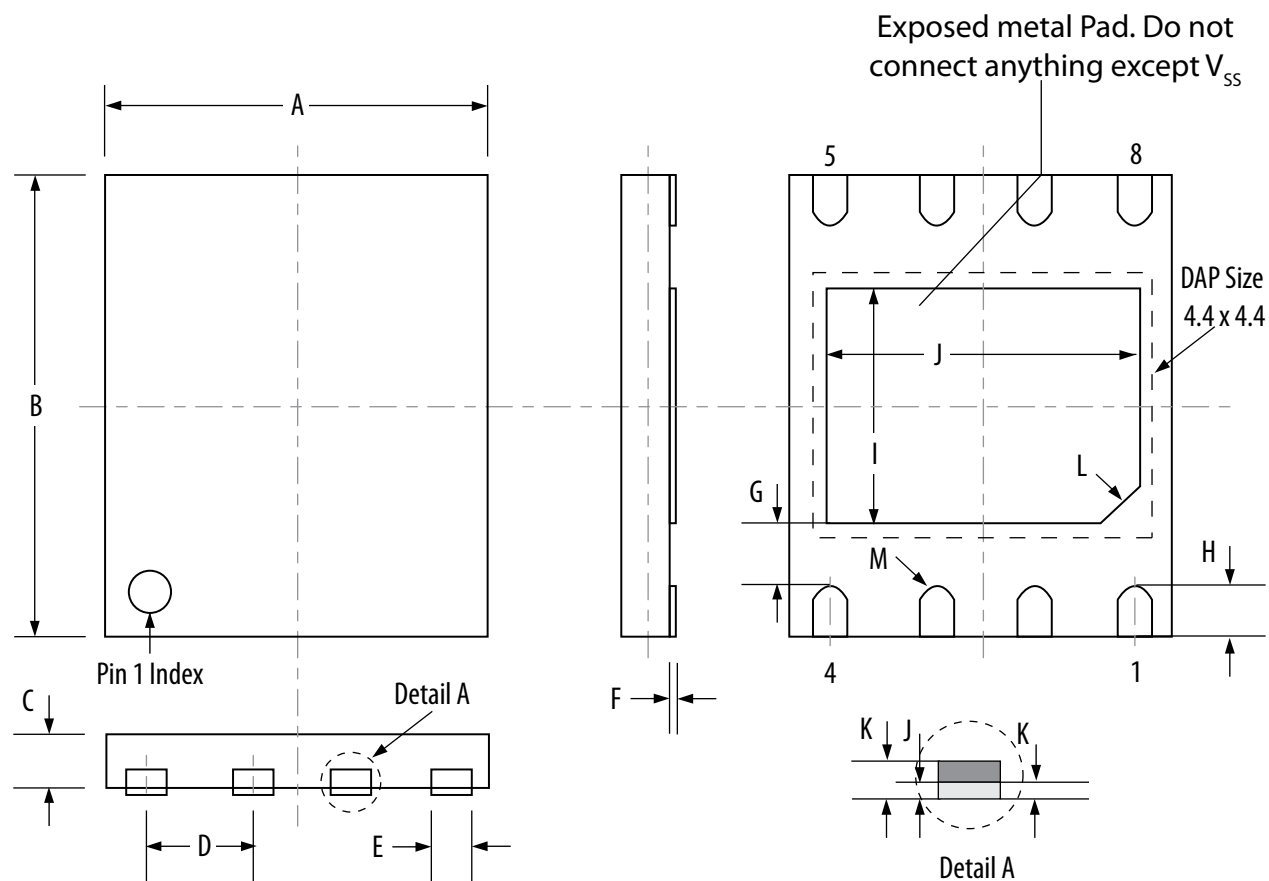

Unit	A	B	C	D	E	F	G	H	I	J	K	L	M
mm - Max	5.10	6.10	1.00	1.27 BSC	0.45	0	0.35 Ref.	0.70	4.20	4.20	0.261	C0.35	R0.20
- Min	4.90	5.9	0.90		0.35	0.05		0.50	4.00	4.00	0.195		

NOTE:

- Angles in degrees.
- Coplanarity applies to the exposed pad as well as the terminals. Coplanarity shall not exceed 0.08 mm.
- Warpage shall not exceed 0.10 mm.
- Refer to JEDEC MO-229

7. REVISION HISTORY

Revision	Date	Description of Change
0	Sep 12, 2008	Initial Advance Information Release
1	Jul 10, 2009	Change ac load resistance, tPU to 400 us, tRDP to 400 us, Change # of Address Bytes in Table 2 to 3, New Package Drawing, Make Preliminary
2	Jul 16, 2009	Increase Absolute Max Magnetic Field during write, read, and standby to 12,000 A/m
3	Jan 5, 2010	Described block protect in detail with power sequencing.
4	Feb 5, 2010	Added section system configuration.
5	May 17, 2010	Removed commercial specifications. All parts meet industrial specifications.

Preliminary - This is a product in development that has fixed target specifications that are subject to change pending characterization results.

How to Reach Us:

Home Page:
www.everspin.com

E-Mail:

support@everspin.com
orders@everspin.com
sales@everspin.com

USA/Canada/South and Central America

Everspin Technologies
1300 N. Alma School Road, CH-409
Chandler, Arizona 85224
+1-877-347-MRAM (6726)
+1-480-347-1111

Europe, Middle East and Africa

support.europe@everspin.com
Wokingham, United Kingdom
+44 (0)118 907 6155

Japan

support.japan@everspin.com
Yokohama, Japan
+81 (0) 45-846-6299

Asia Pacific

support.asia@everspin.com

Document Control Number:

M25H10 Revision 5.1, 5/2010

File Name:

EST_MR25H10_prod.pdf

Information in this document is provided solely to enable system and software implementers to use Everspin Technologies products. There are no express or implied licenses granted hereunder to design or fabricate any integrated circuit or circuits based on the information in this document. Everspin Technologies reserves the right to make changes without further notice to any products herein. Everspin makes no warranty, representation or guarantee regarding the suitability of its products for any particular purpose, nor does Everspin Technologies assume any liability arising out of the application or use of any product or circuit, and specifically disclaims any and all liability, including without limitation consequential or incidental damages. "Typical" parameters, which may be provided in Everspin Technologies data sheets and/or specifications can and do vary in different applications and actual performance may vary over time. All operating parameters including "Typicals" must be validated for each customer application by customer's technical experts. Everspin Technologies does not convey any license under its patent rights nor the rights of others. Everspin Technologies products are not designed, intended, or authorized for use as components in systems intended for surgical implant into the body, or other applications intended to support or sustain life, or for any other application in which the failure of the Everspin Technologies product could create a situation where personal injury or death may occur. Should Buyer purchase or use Everspin Technologies products for any such unintended or unauthorized application, Buyer shall indemnify and hold Everspin Technologies and its officers, employees, subsidiaries, affiliates, and distributors harmless against all claims, costs, damages, and expenses, and reasonable attorney fees arising out of, directly or indirectly, any claim of personal injury or death associated with such unintended or unauthorized use, even if such claim alleges that Everspin Technologies was negligent regarding the design or manufacture of the part. Everspin™ and the Everspin logo are trademarks of Everspin Technologies, Inc. All other product or service names are the property of their respective owners.

©Everspin Technologies, Inc. 2009

