

Device Overview

The IDT 89HP0608X (P0608X) is a 1.25Gbps to 6.25Gbps Repeater IC that reconditions high-speed serial data streams. The device features IDT EyeBoost™ technology that compensates for cable and board trace attenuations and ISI jitter, thereby extending connection reach. The device is optimized for XAUI high-speed, serial differential data streams and contains eight data channels, each able to process up to 6.25Gbps transmission rates. Each channel consists of an input equalizer and amplifier, signal detection with glitch filter, as well as programmable output swing, slew rate, and de-emphasis with delay control. Since all of these features are user programmable, they allow for application specific optimization.

Besides the per channel programmable features, the P0608X provides global programmable settings - termination resistance values and transfer modes. The P0608X, with its many programmable receiver and transmitter features, is ideal for applications using any combination of cables and board trace materials.

All modes of active data transfer are designed with minimized power consumption. Also, a wide selection of power reducing modes allows the user to eliminate power of unused blocks, including a shutdown mode. In full shutdown mode, the part consumes less than 80mW in worst case environmental conditions.

Applications

- ◆ Telecommunications
- ◆ Networking
- ◆ 10GbE systems

Features

- ◆ Compensates for cable and PCB trace attenuation and ISI jitter
- ◆ Programmable receiver equalization up to 30db
- ◆ Programmable de-emphasis up to -8.5dB
- ◆ Minimized in-out latency of 300ps typical
- ◆ Recovers data stream even when the differential signal eye is completely closed due to trace attenuation and ISI jitter
- ◆ Full XAUI protocol support
- ◆ Configurable via I²C interface
- ◆ Supports automatic download of configuration from external EEPROM with a single or multiple repeaters on I2C bus
- ◆ Leading edge power minimization in active and shutdown modes
- ◆ No external bias resistors or reference clocks required
- ◆ Channel mux mode, demux mode, 1 to 2 channels multicast, and Z-switch function mode
- ◆ Available in a 9x9mm 100-ball FPBGA package

Benefits

- ◆ Extends maximum cable length to over 10 meters and trace length over 65 inches in cabled applications (short/medium/long range and beyond long range)
- ◆ Speeds up system design time by allowing usage of longer trace and cable lengths
- ◆ Minimizes BER

Typical Application

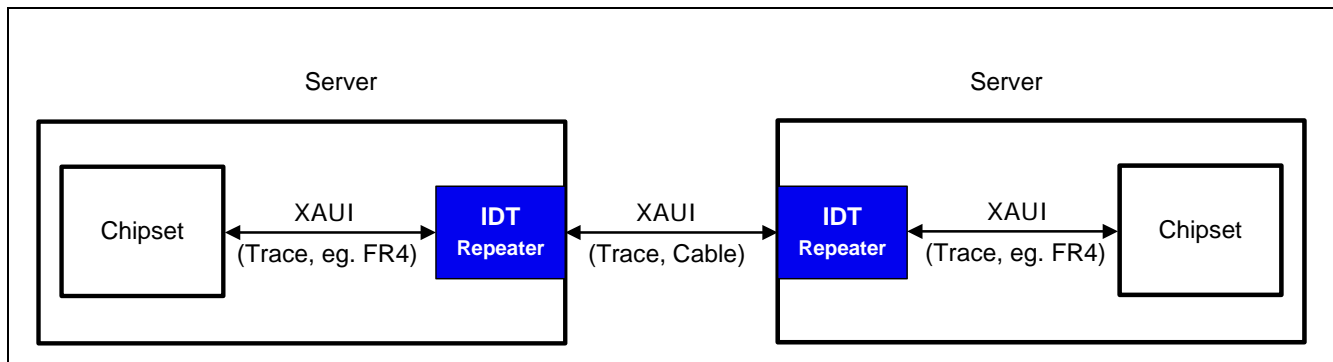

Figure 1 IDT Repeater in Blade Servers

P0608X Block Diagram

The P0608X contains eight high speed channels as shown in Figure 2. Each channel can be routed to different outputs. Depending on user configuration via mode selections, input traffic can be muxed, demuxed, or looped back. Please refer to modes of operation chapter for details. To facilitate buffering of system clocks, the repeater provides 1:2 clock buffer as shown in the figure below. Powerdown (PDB) and Channel Enable (AEN0, etc.) pins are provided for easy state and channel control. Status output pins are available for monitoring critical states, such as the detection of high speed input signals (A0SIGDET, etc.).

Each channel's configuration and performance can be optimized via the I²C interface (SCL, SDA). The programming option allows the user to optimize the repeater's performance in a wide range of applications, making it an ideal solution for most applications requiring cancellation of trace or cable attenuation and ISI jitter.

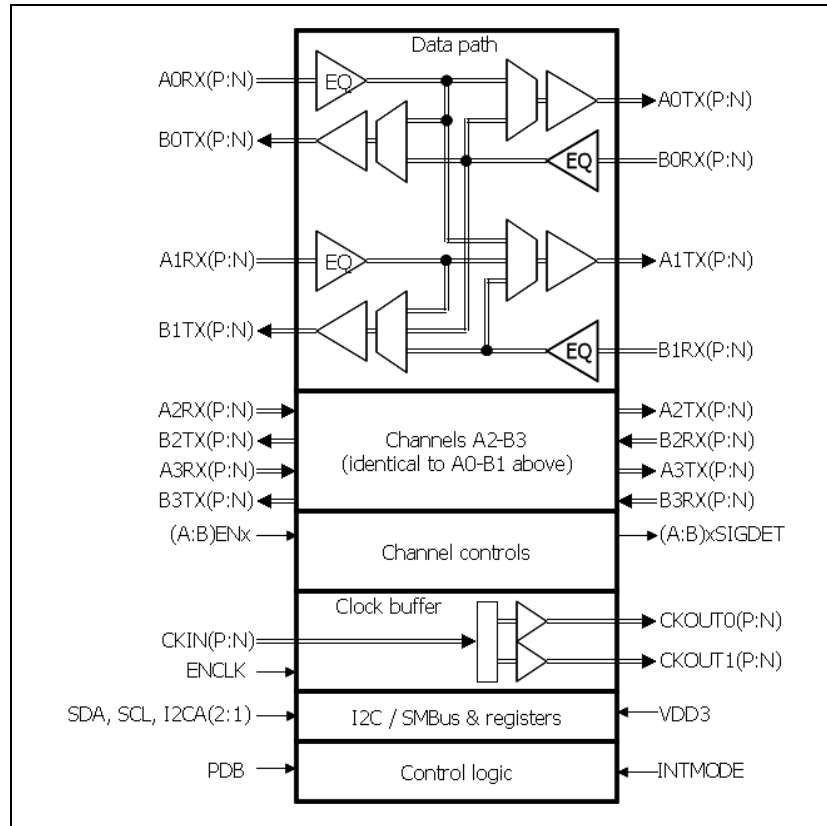

Figure 2 P0608X Block Diagram

NOT AN OFFER FOR SALE

The information presented herein is subject to a Non-Disclosure Agreement and is for planning purposes only. Nothing contained in this presentation, whether verbal or written, is intended as, or shall have the effect of, a sale or an offer for sale that creates a contractual power of acceptance.



CORPORATE HEADQUARTERS
 6024 Silver Creek Valley Road
 San Jose, CA 95138

for SALES:
 800-345-7015 or 408-284-8200
 fax: 408-284-2775
 www.idt.com

for Tech Support:
 email: ssdhelp@idt.com
 phone: 408-284-8208