



## Device Overview

The IDT 89HP0508P (P0508P) is a 5Gbps PCIe® Repeater device featuring IDT EyeBoost™ technology that compensates for cable and board trace attenuations and ISI jitter, thereby extending connection reach. The device is optimized for PCIe Gen1 and Gen2 high speed serial data streams and contains eight data channels, each able to process 5Gbps transmission rates. Each channel consists of an input equalizer and amplifier, signal detection with glitch filter, as well as programmable output swing, slew rate, and de-emphasis with delay control. Since all of these features are user programmable, they allow for application specific optimization.

Besides the per channel programmable features, the P0508P provides global programmable settings - termination resistance values and transfer modes. The P0508P, with its many programmable receiver and transmitter features, is ideal for PCIe applications using any combination of cables and board trace materials.

All modes of active data transfer are designed with minimized power consumption. Also, a wide selection of power reducing modes allows the user to eliminate power of unused blocks, including a shutdown mode. In full shutdown mode, the part consumes less than 80mW in worst case environmental conditions.

## Applications

- ◆ Blade servers, rack servers
- ◆ PCIe instrumentation
- ◆ Storage systems
- ◆ Cabled PCIe devices

## Features

- ◆ Compensates for cable and PCB trace attenuation and ISI jitter
- ◆ Programmable receiver equalization up to 30db
- ◆ Programmable de-emphasis up to -8.5dB
- ◆ Recovers data stream even when the differential signal eye is completely closed due to trace attenuation and ISI jitter
- ◆ Full PCIe protocol support
- ◆ Configurable via I<sup>2</sup>C interface
- ◆ Supports automatic download of configuration from external EEPROM with a single or multiple repeaters on I2C bus
- ◆ Leading edge power minimization in active and shutdown modes
- ◆ No external bias resistors or reference clocks required
- ◆ Channel mux mode, demux mode, 1 to 2 channels multicast, and Z-switch function mode
- ◆ Available in a 9x9mm 100-ball FPBGA package

## Benefits

- ◆ Extends maximum cable length to over 10 meters and trace length over 65 inches in PCIe applications
- ◆ Speeds up system design time by allowing usage of longer trace and cable lengths
- ◆ Minimizes BER

## Typical Application

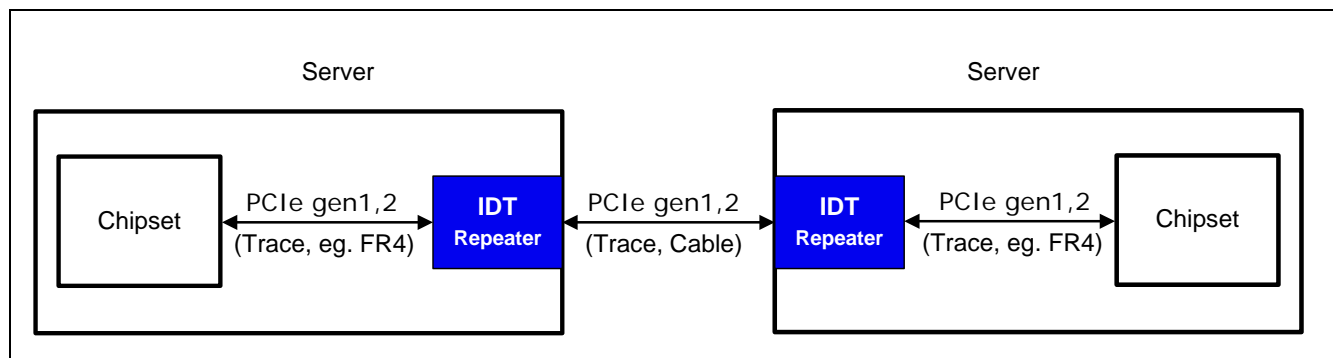

Figure 1 IDT Repeaters in Blade Servers

## P0508P PCIe Compliance

The device was designed to provide end users with features needed to comply with PCIe system application requirements:

- Receiver Detection Support, PCIe Beacon Support
- Receiver supports high impedance mode for PCIe
- Jitter, eye opening, and all other AC and DC specifications.

## P0508P Block Diagram

The P0508P contains eight high speed channels as shown in Figure 2. Each channel can be routed to different outputs. Depending on user configuration via mode selections, input traffic can be muxed, demuxed, or looped back. Please, refer to modes of operation chapter for details. To facilitate buffering of system clocks, the repeater provides 1:2 clock buffer as shown in the figure below. Powerdown (PDB) and Receiver Detection Reset (RSTB) pins are provided for easy state and channel control. Status output pins are available for monitoring critical states, such as the detection of high speed input signals (A0SIGDET, etc.) and the far-end receiver detection (ARXDETSTAT, etc.).

Each channel's configuration and performance can be optimized via the I<sup>2</sup>C interface (SCL, SDA). The programming option allows the user to optimize the repeater's performance in a wide range of applications, making it an ideal solution for most applications requiring cancellation of trace or cable attenuation and ISI jitter.

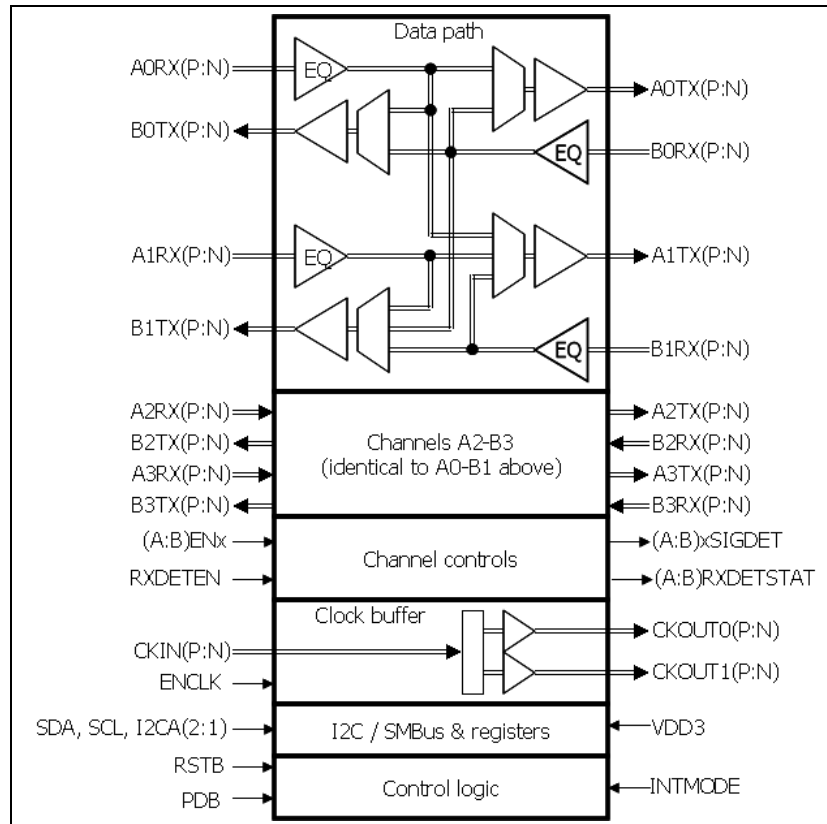

Figure 2 P0508P Block Diagram

NOT AN OFFER FOR SALE

The information presented herein is subject to a Non-Disclosure Agreement and is for planning purposes only. Nothing contained in this presentation, whether verbal or written, is intended as, or shall have the effect of, a sale or an offer for sale that creates a contractual power of acceptance.



**CORPORATE HEADQUARTERS**  
6024 Silver Creek Valley Road  
San Jose, CA 95138

**for SALES:**  
800-345-7015 or 408-284-8200  
fax: 408-284-2775  
www.idt.com

**for Tech Support:**  
email: [ssdhelp@idt.com](mailto:ssdhelp@idt.com)  
phone: 408-284-8208