

### Device Overview

The IDT 89HP0604S is a 1.5Gbps to 6Gbps Repeater IC featuring IDT EyeBoost™ technology that compensates for cable and board trace attenuations and ISI jitter, thereby extending connection reach. The 89HP0604S contains four half-duplex data lanes. Each channel consists of an input equalizer and amplifier, signal detection with glitch filter, as well as programmable output swing, slew rate, and de-emphasis with delay control. Since all of these features are user programmable, they allow for application specific optimization.

Besides the per channel programmable features, the P0604S provides global programmable settings - termination resistance values and transfer modes.

The P0604S, with its many programmable receiver and transmitter features, is ideal for the needs of SAS/SATA applications.

All modes of active data transfer are designed with minimized power consumption. Also, a wide selection of power reducing modes allows the user to eliminate power of unused blocks. In full shutdown mode, the part consumes less than 40mW in worst case environmental conditions.

### Applications

- ◆ Blade servers, rack servers
- ◆ SAS/SATA instrumentation
- ◆ Storage systems
- ◆ Cabled SAS/SATA devices

### Features

- ◆ Compensates for cable and PCB trace attenuation and ISI jitter
- ◆ Programmable receiver equalization up to 30db
- ◆ Programmable de-emphasis up to -8.5dB

- ◆ Recovers data stream even when the differential signal eye is completely closed due to trace attenuation and ISI jitter
- ◆ Full SAS/SATA protocol and Out-of-Band (OOB) support
- ◆ Configurable via external pins, while extended programming ranges are available via I<sup>2</sup>C interface
- ◆ Supports automatic download of configuration from external EEPROM with a single or multiple repeaters on I2C bus
- ◆ Leading edge power minimization in active and shutdown modes
- ◆ No external bias resistors or reference clocks required
- ◆ Channel mux mode, demux mode, 1 to 2 channels multicast, and Z-switch function mode
- ◆ Packages available:
  - Option A Package: 100-ball (9x9mm) FPBGA
  - Option B Package: 36-QFN (4x7.5mm)

### Benefits

- ◆ Extends maximum cable length to over 10 meters and trace length over 65 inches in SAS/SATA applications
- ◆ Speeds up system design time by allowing usage of longer trace and cable lengths
- ◆ Minimizes BER

### P0604S SAS/SATA Compliance

The device was designed to provide end users with features needed to comply with SAS/SATA system application requirements:

- SAS/SATA Out-of-Band (OOB) Support
- Jitter, eye opening, and all other AC and DC specifications.

### Typical Application

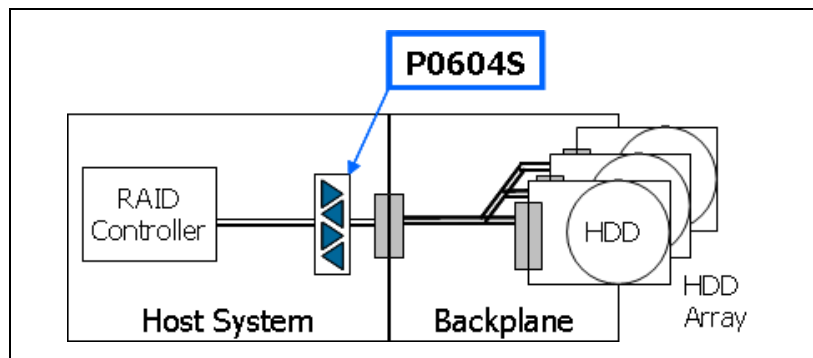

Figure 1 IDT Repeaters in Storage Backplanes

## P0604S Package Options

The P0604S is offered with two package options as shown in Figure 2. The 100-pin BGA package provides extensive pin configuration input and status output features in addition to I<sup>2</sup>C configuration. The 36-QFN package option requires the I<sup>2</sup>C slave on local EEPROM for optimized configuration and status reporting. Note that references in this document to specific control and status output signal pins may not be available in the 36-QFN package.

## P0604S Block Diagram

The P0604S contains four high speed channels. Each channel can be routed to different outputs. Depending on user configuration via mode selections, input traffic can be muxed, demuxed, or looped back. Please, refer to modes of operation chapter for details. To facilitate buffering of system clocks, the repeater provides 1:2 clock buffer as shown in the figure below. Powerdown (PDB) and channel enable input pins (A0EN, etc.) are provided for easy state and channel control. Status output pins are available for monitoring critical states, such as the detection of high speed input signals (A0SIGDET, etc.).

Each channel's configuration and performance can be optimized via programming pins (refer to Table 35) or via the I<sup>2</sup>C interface (SCL, SDA, A0-A2). The programming option allows the user to optimize the repeater's performance in a wide range of applications, making it an ideal solution for most applications requiring cancellation of trace or cable attenuation and ISI jitter.

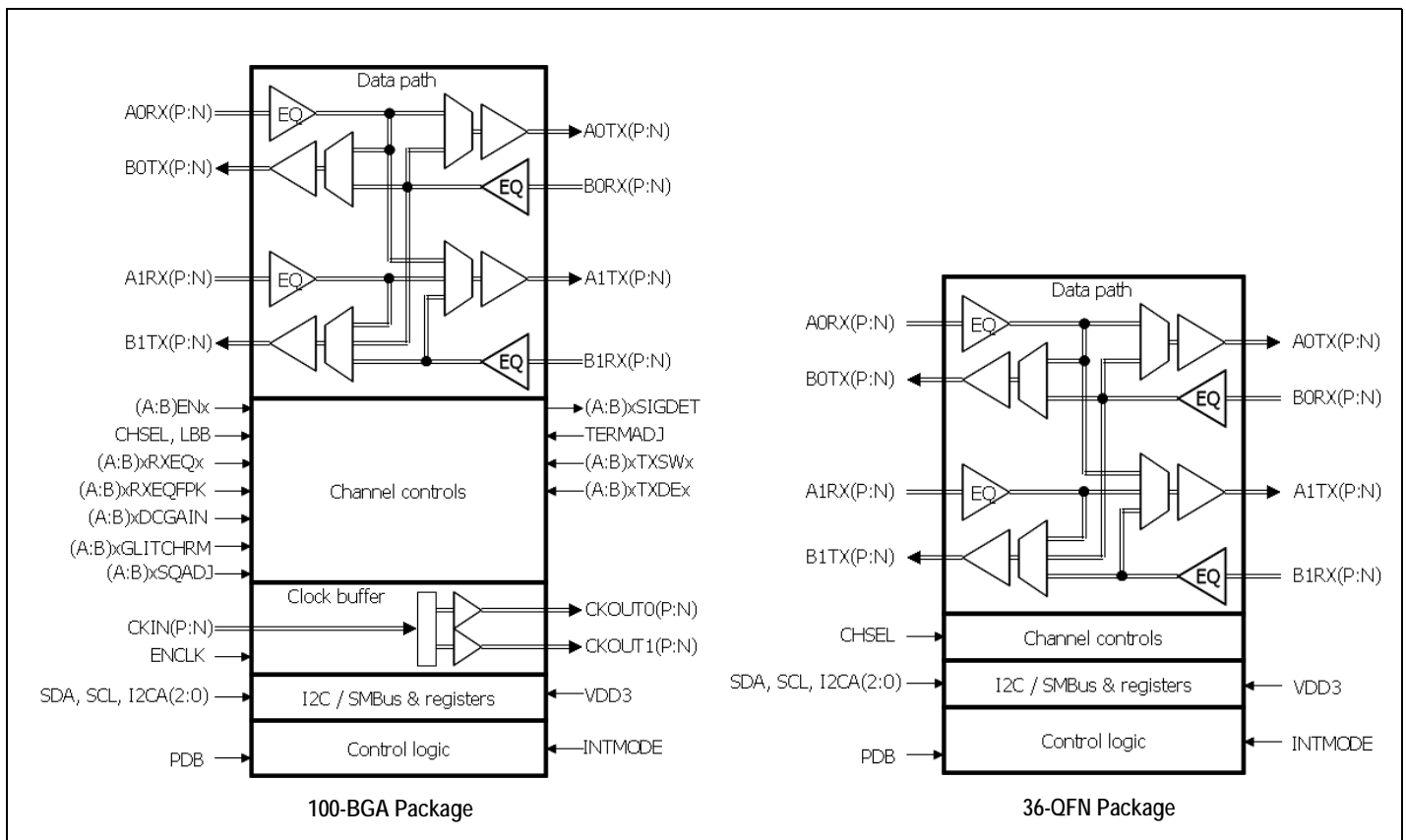

Figure 2 P0604S Block Diagrams

NOT AN OFFER FOR SALE

The information presented herein is subject to a Non-Disclosure Agreement and is for planning purposes only. Nothing contained in this presentation, whether verbal or written, is intended as, or shall have the effect of, a sale or an offer for sale that creates a contractual power of acceptance.



**CORPORATE HEADQUARTERS**  
6024 Silver Creek Valley Road  
San Jose, CA 95138

**for SALES:**  
800-345-7015 or 408-284-8200  
fax: 408-284-2775  
www.idt.com

**for Tech Support:**  
email: ssdhelp@idt.com  
phone: 408-284-8208