

## ML610Q428/ML610Q429

8-bit Microcontroller with a Built-in LCD driver

### GENERAL DESCRIPTION

This LSI is a high-performance 8-bit CMOS microcontroller into which rich peripheral circuits, such as synchronous serial port, UART, I2C bus interface (master), melody driver, battery level detect circuit, RC oscillation type A/D converter, and LCD driver, are incorporated around 8-bit CPU nX-U8/100.

The CPU nX-U8/100 is capable of efficient instruction execution in 1-instruction 1-clock mode by 3-stage pipe line architecture parallel processing. The Flash ROM that is installed as program memory achieves low-voltage low-power consumption operation (read operation) equivalent to mask ROM and is most suitable for battery-driven applications.

The on-chip debug function that is installed enables program debugging and programming.

### FEATURES

- CPU
  - 8-bit RISC CPU (CPU name: nX-U8/100)
  - Instruction system: 16-bit instructions
  - Instruction set: Transfer, arithmetic operations, comparison, logic operations, multiplication/division, bit manipulations, bit logic operations, jump, conditional jump, call return stack manipulations, arithmetic shift, and so on
  - On-Chip debug function
  - Minimum instruction execution time
    - 30.5  $\mu$ s (@32.768 kHz system clock)
    - 0.24  $\mu$ s (@4.096 MHz system clock)
- Internal memory
  - Internal 48KByte Flash ROM (24K $\times$ 16 bits) (including unusable 1KByte TEST area)
  - Internal 3KByte Data RAM (3072 $\times$ 8 bits), 1KByte Display Allocation RAM (1024 x 8bit)
  - Internal 192-byte RAM for display
- Interrupt controller
  - 2 non-maskable interrupt sources (Internal source: 1, External source: 1)
  - 27 maskable interrupt sources (Internal sources: 19, External sources: 8)
- Time base counter
  - Low-speed time base counter  $\times$ 1 channel
    - Frequency compensation (Compensation range: Approx.  $-488$ ppm to  $+488$ ppm. Compensation accuracy: Approx. 0.48ppm)
  - High-speed time base counter  $\times$ 1 channel
- Watchdog timer
  - Non-maskable interrupt and reset
  - Free running
  - Overflow period: 4 types selectable (125ms, 500ms, 2s, and 8s)
- Timers
  - 8 bits  $\times$  2 channels (16-bit configuration available)
- 1 kHz timer
  - 10 Hz/1 Hz interrupt function

- PWM
  - Resolution 16 bits × 3 channel
- Synchronous serial port
  - Master/slave selectable
  - LSB first/MSB first selectable
  - 8-bit length/16-bit length selectable
  - Timer interrupt is used as a serial clock and selection is possible
- UART
  - TXD/RXD × 1 channel
  - Bit length, parity/no parity, odd parity/even parity, 1 stop bit/2 stop bits
  - Positive logic/negative logic selectable
  - Built-in baud rate generator
- I<sup>2</sup>C bus interface
  - Master function only
  - Fast mode (400 kbps@4MHz), standard mode (100 kbps@1MHz, 50kbps@500kHz)
- Melody driver
  - Scale: 29 types (Melody sound frequency: 508 Hz to 32.768 kHz)
  - Tone length: 63 types
  - Tempo: 15 types
  - Buzzer output mode (4 output modes, 8 frequencies, 16 duty levels)
- RC oscillation type A/D converter
  - 24-bit counter
  - Time division × 2 channels
- Successive approximation type A/D converter
  - 12-bit A/D converter
  - Input × 2 channels
- General-purpose ports
  - Non-maskable interrupt input port × 1 channel
  - Input-only port × 10 channels (including secondary functions)
  - Output-only port × 3 channels (including secondary functions)
  - Input/output port
    - ML610Q428: 14 channels (including secondary functions)
    - ML610Q429: 20 channels (including secondary functions)

- LCD driver
  - Dot matrix can be supported.  
ML610Q428: 1392 dots max. (58 seg × 24 com), 1/1 to 1/24 duty  
ML610Q429: 512 dots max. (64 seg × 8 com) , 1/1 to 1/8 duty
  - 1/3 or 1/4 bias (built-in bias generation circuit)
  - Frame frequency selectable (approx. 32Hz, 64 Hz, 73 Hz, 85 Hz, and 102 Hz)
  - Bias voltage multiplying clock selectable (8 types)
  - Contrast adjustment (1/3 bias: 32 steps, 1/4 bias: 20 steps)
  - LCD drive stop mode, LCD display mode, all LCDs on mode, and all LCDs off mode selectable
  - Programmable display allocation function (available only when 1/1~1/8 duty is selected)
  - The metal option of only ML610Q429  
Type B : 8com x 64seg (seg63 to seg0: segment port)  
Type C : 8com x 56seg (seg63 to seg56: output port, seg55 to seg0: segment port)  
Type D : 8com x 48seg (seg63 to seg48: output port, seg47 to seg0: segment port)  
Type E : 8com x 40seg (seg63 to seg40: output port, seg39 to seg0: segment port)  
Type F : 8com x 32seg (seg63 to seg32: output port, seg31 to seg0: segment port)
- Reset
  - Reset through the RESET\_N pin
  - Power-on reset generation when powered on
  - Reset when oscillation stop of the low-speed clock is detected
  - Reset by the watchdog timer (WDT) overflow
- Power supply voltage detect function
  - Judgment voltages: One of 16 levels
  - Judgment accuracy: ±2% (Typ.)
- Clock
  - Low-speed clock: (This LSI can not guarantee the operation without low-speed clock)  
Crystal oscillation (32.768 kHz)
  - High-speed clock:  
Built-in RC oscillation (2M/500kHz)  
Built-in PLL oscillation (8.192 MHz ±TBD%), crystal/ceramic oscillation (4.096 MHz), external clock
  - Selection of high-speed clock mode by software:  
Built-in RC oscillation, built-in PLL oscillation, crystal/ceramic oscillation, external clock
- Power management
  - HALT mode: Instruction execution by CPU is suspended (peripheral circuits are in operating states).
  - STOP mode: Stop of low-speed oscillation and high-speed oscillation (Operations of CPU and peripheral circuits are stopped.)
  - Clock gear: The frequency of high-speed system clock can be changed by software (1/1, 1/2, 1/4, or 1/8 of the oscillation clock)
  - Block Control Function: Power down (reset registers and stop clock supply) the circuits of unused peripherals.
- Shipment
  - Chip (Die)  
ML610Q428-xxxWA (Blank product: ML610Q428-NNNWA)  
ML610Q429-xxxWA (Blank product: ML610Q429-NNNWA)
  - 128-pin plastic TQFP  
ML610Q428-xxxTBZ03A (Blank product: ML610Q428-NNNTBZ03A)  
ML610Q429-xxxTBZ03A (Blank product: ML610Q429-NNNTBZ03A)  
xxx: ROM code number
- Guaranteed operating range
  - Operating temperature: -20°C to 70°C
  - Operating voltage: V<sub>DD</sub> = 1.1V to 3.6V

**BLOCK DIAGRAM**  
**ML610Q428 Block Diagram**

Figure 1 show the block diagram of the ML610Q428.  
"\*" indicates the secondary function of each port.

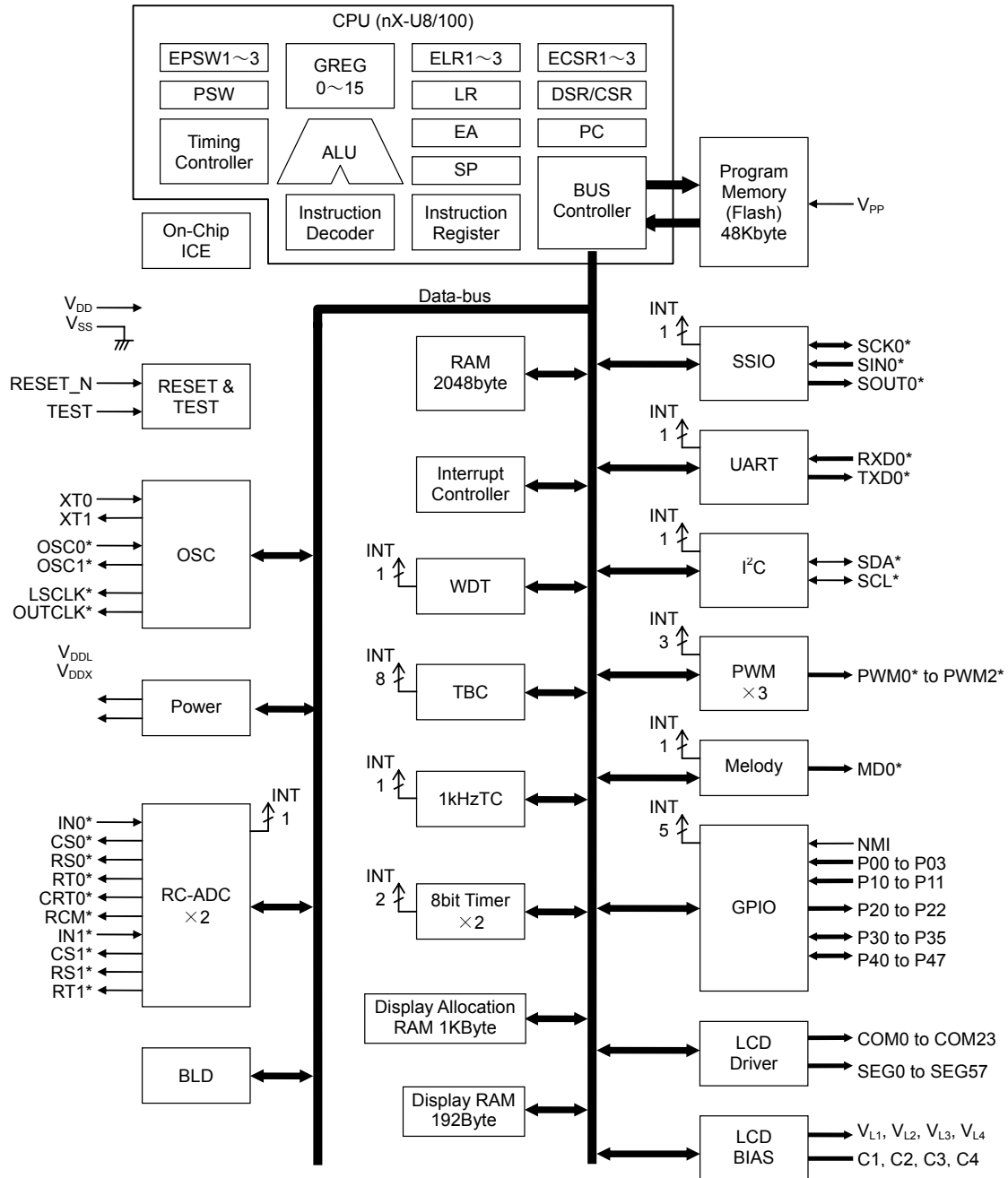

**Figure 1 ML610Q428 Block Diagram**

**ML610Q429 Block Diagram**

Figure 2 show the block diagram of the ML610Q429.  
 "\*" indicates the secondary function of each port.

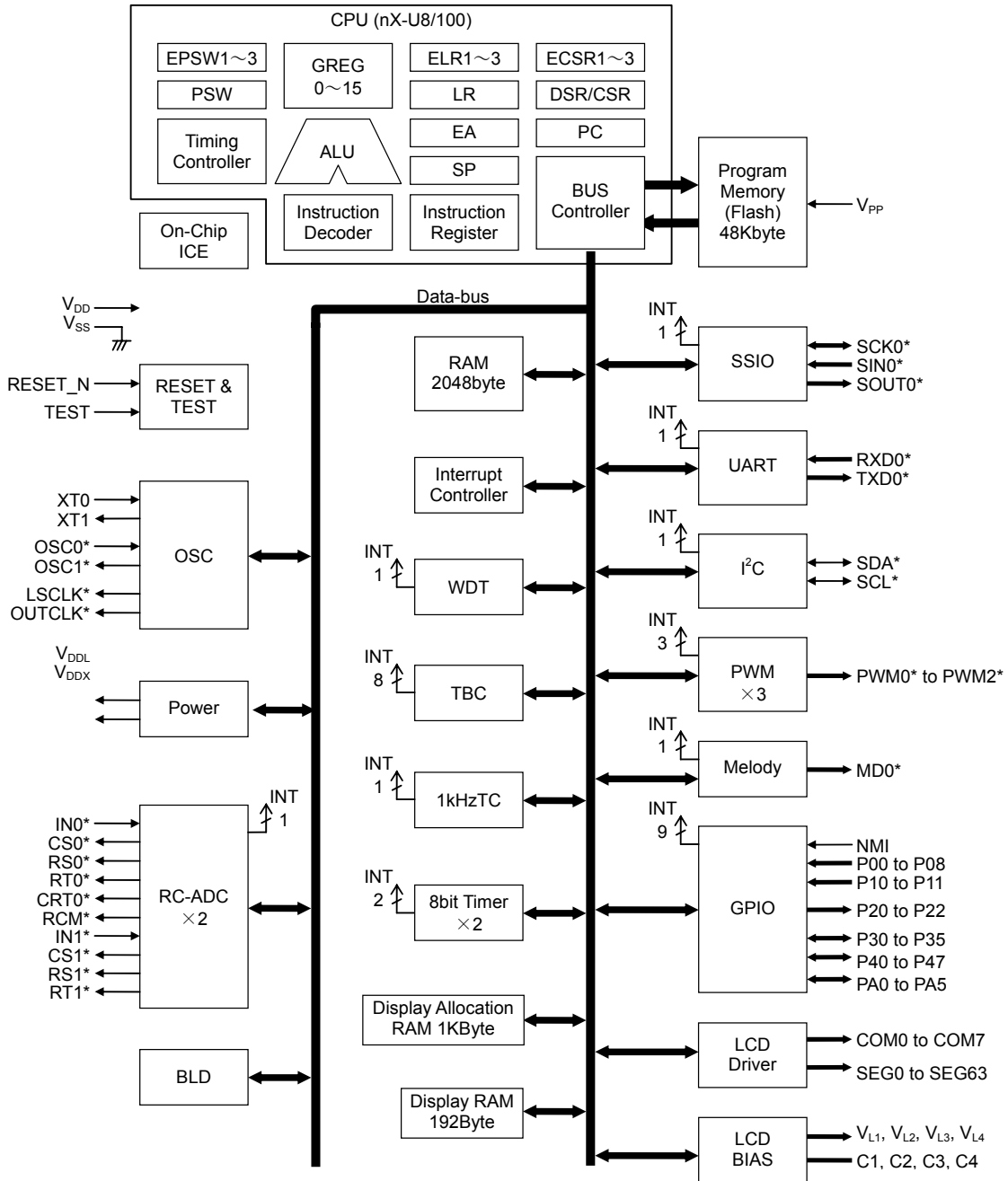

**Figure 2 ML610Q429 Block Diagram**

**PIN CONFIGURATION**  
**ML610Q428 TQFP128 Pin Layout**

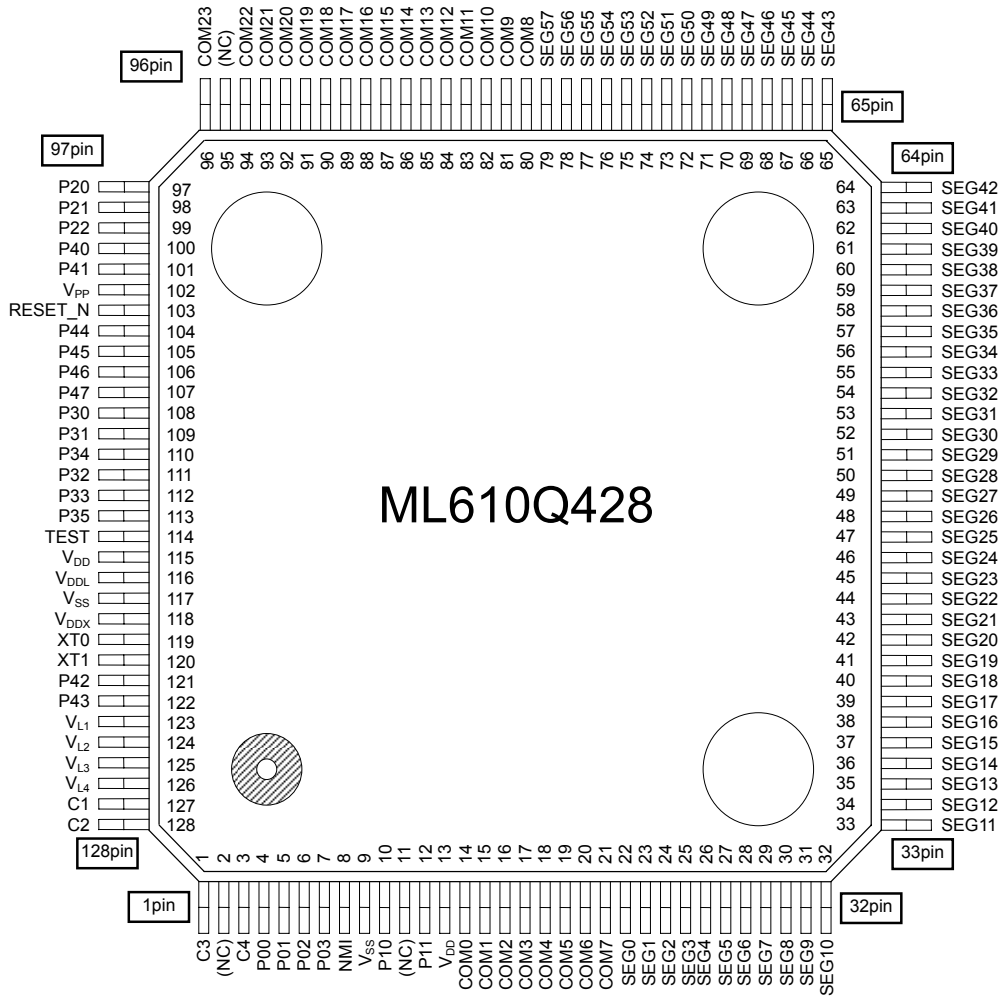

(NC): No Connection

**Figure 3 ML610Q428 TQFP128 Pin Configuration**

ML610Q429 TQFP128 Pin Layout

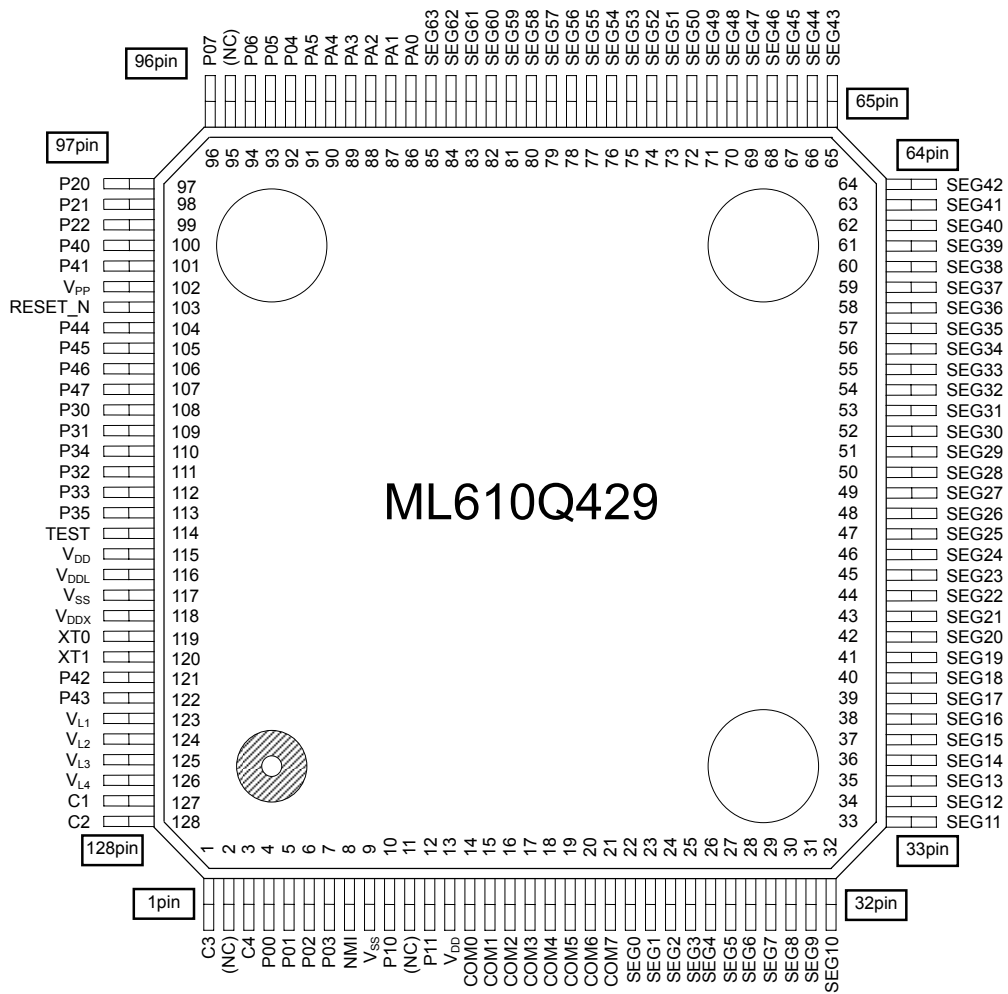

(NC): No Connection

Figure 4 ML610Q429 TQFP128 Pin Configuration

**ML610Q428 Chip Dimension**

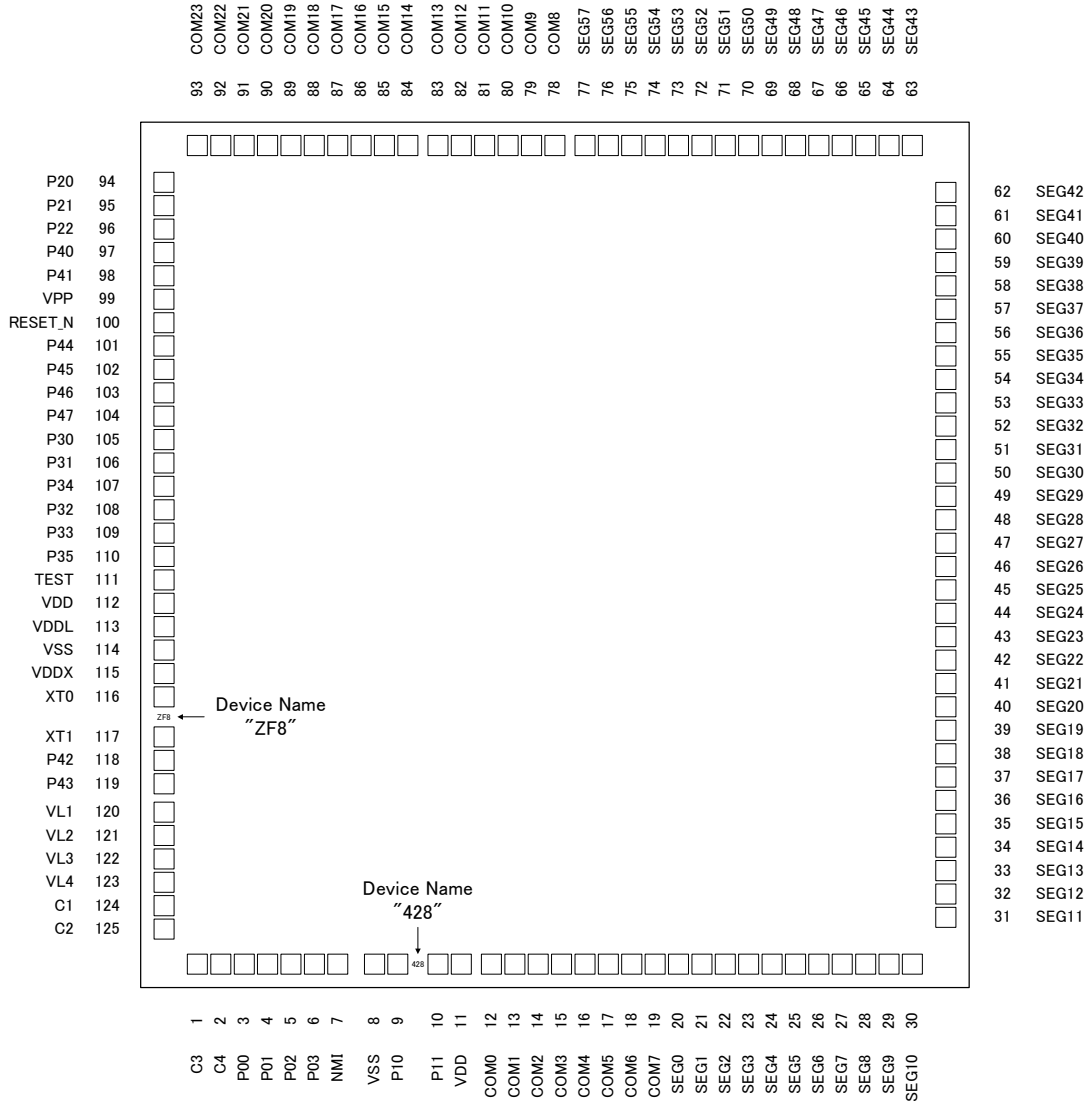

Chip size: 2.99 mm × 3.11 mm  
 PAD count: 125 pins  
 Minimum PAD pitch: 80 μm  
 PAD aperture: 70 μm × 70 μm  
 Chip thickness: 350 μm  
 Voltage of the rear side of chip: V<sub>SS</sub> level

**Figure 5 ML610Q428 Chip Dimension**

**Note:**

Figure 5 is an image figure of the order of PAD, and it differs from an actual image. Refer to the PAD coordinate for detailed arrangement.

A chip angle can be checked by the distinguishing mark of three figures.



**ML610Q429 Chip Dimension**

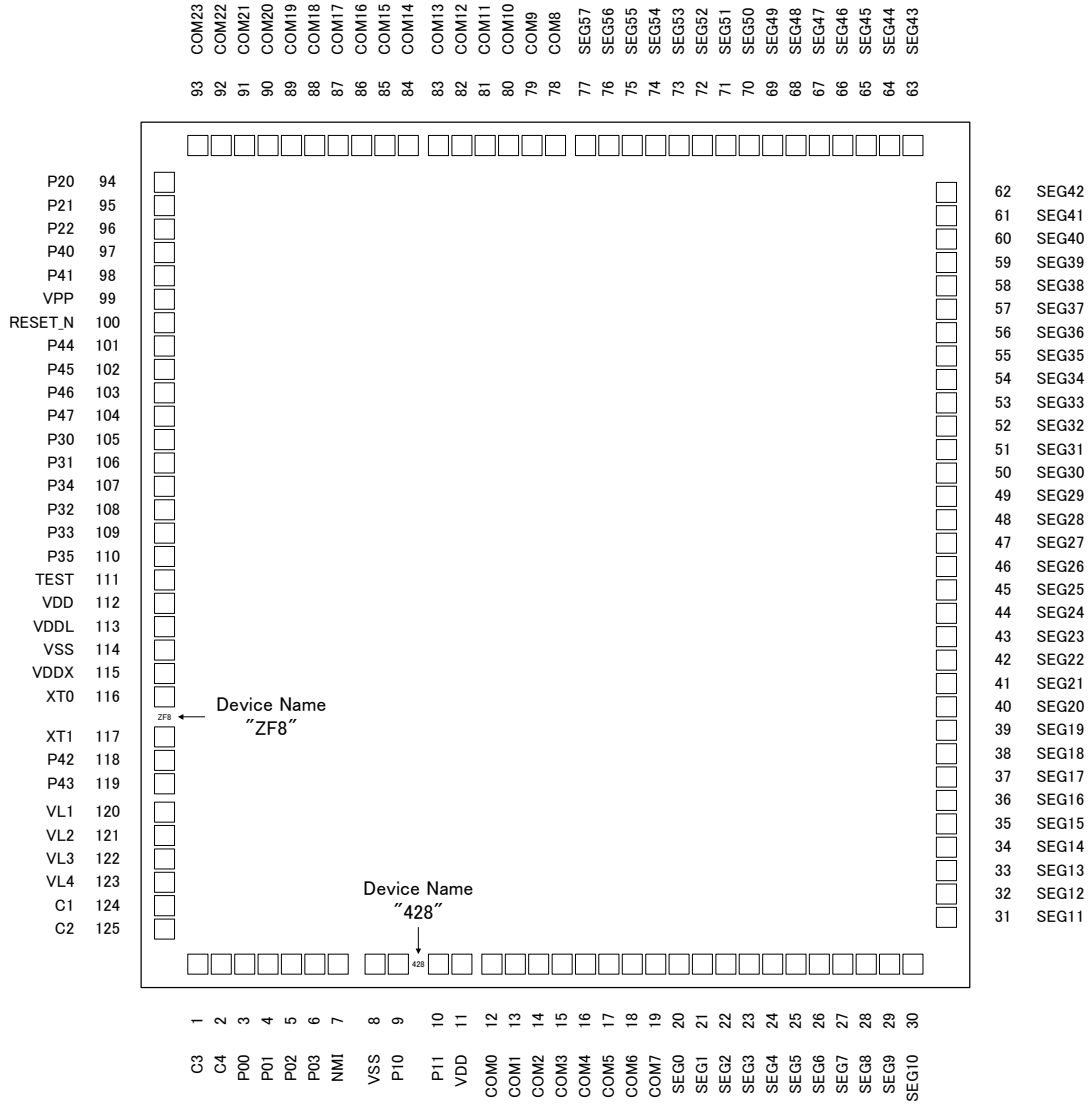

Chip size: 2.99 mm × 3.11 mm  
 PAD count: 125 pins  
 Minimum PAD pitch: 80 μm  
 PAD aperture: 70 μm × 70 μm  
 Chip thickness: 350 μm  
 Voltage of the rear side of chip: V<sub>SS</sub> level

**Figure 6 ML610Q429 Chip Dimension**

**Note:**

Figure 6 is an image figure of the order of PAD, and it differs from an actual image. Refer to the PAD coordinate for detailed arrangement.

A chip angle can be checked by the distinguishing mark of three figures.

## PIN LIST

PAD No.		Primary function			Secondary function			Tertiary function		
Q429	Q428	Pin name	I/O	Function	Pin name	I/O	Function	Pin name	I/O	Function
8,114	8,114	V <sub>SS</sub>	—	Negative power supply pin	—	—	—	—	—	—
11,112	11,112	V <sub>DD</sub>	—	Positive power supply pin	—	—	—	—	—	—
113	113	V <sub>DDL</sub>	—	Power supply pin for internal logic (internally generated)	—	—	—	—	—	—
115	115	V <sub>DDX</sub>	—	Power supply pin for low-speed oscillation (internally generated)	—	—	—	—	—	—
99	99	V <sub>PP</sub>	—	Power supply pin for Flash ROM	—	—	—	—	—	—
120	120	V <sub>L1</sub>	—	Power supply pin for LCD bias (internally generated)	—	—	—	—	—	—
121	121	V <sub>L2</sub>	—	Power supply pin for LCD bias (internally generated)	—	—	—	—	—	—
122	122	V <sub>L3</sub>	—	Power supply pin for LCD bias (internally generated)	—	—	—	—	—	—
123	123	V <sub>L4</sub>	—	Power supply pin for LCD bias (internally generated)	—	—	—	—	—	—
124	124	C1	—	Capacitor connection pin for LCD bias generation	—	—	—	—	—	—
125	125	C2	—	Capacitor connection pin for LCD bias generation	—	—	—	—	—	—
1	1	C3	—	Capacitor connection pin for LCD bias generation	—	—	—	—	—	—
2	2	C4	—	Capacitor connection pin for LCD bias generation	—	—	—	—	—	—
111	111	TEST	I/O	Input/output pin for testing	—	—	—	—	—	—
100	100	RESET_N	I	Reset input pin	—	—	—	—	—	—
116	116	XT0	I	Low-speed clock oscillation pin	—	—	—	—	—	—
117	117	XT1	O	Low-speed clock oscillation pin	—	—	—	—	—	—
7	7	NMI	I	Non-maskable interrupt pin	—	—	—	—	—	—
3	3	P00/EXI0	I	Input port, External interrupt 0 input	—	—	—	—	—	—
4	4	P01/EXI1	I	Input port, External interrupt 1 input	—	—	—	—	—	—
5	5	P02/EXI2 /RXD0 /P2CK	I	Input port, External interrupt 2, UART0 receive, PWM2 external clock input	—	—	—	—	—	—
6	6	P03/EXI3	I	Input port, External interrupt 3	—	—	—	—	—	—
90	—	P04/EXI4	I/O	Input port, External interrupt 4	—	—	—	—	—	—
91	—	P05/EXI5	I/O	Input port, External interrupt 5	—	—	—	—	—	—
92	—	P06/EXI6	I/O	Input port, External interrupt 6	—	—	—	—	—	—
93	—	P07/EXI7	I/O	Input port, External	—	—	—	—	—	—

PAD No.		Primary function			Secondary function			Tertiary function		
Q429	Q428	Pin name	I/O	Function	Pin name	I/O	Function	Pin name	I/O	Function
				interrupt 7						
9	9	P10	I	Input port	OSC0	I	High-speed oscillation	—	—	—
10	10	P11	I	Input port	OSC1	O	High-speed oscillation	—	—	—
94	94	P20/LED0	O	Output port	LSCLK	O	Low-speed clock output	PWM2	O	PWM2 output
95	95	P21/LED1	O	Output port	OUTCLK	O	High-speed clock output	—	—	—
96	96	P22/LED2	O	Output port	MD0	O	Melody output	—	—	—
105	105	P30	I/O	Input/output port	IN0	I	RC type ADC0 oscillation input pin	PWM2	O	PWM2 output
106	106	P31	I/O	Input/output port	CS0	O	RC type ADC0 reference capacitor connection pin	—	—	—
108	108	P32	I/O	Input/output port	RS0	O	RC type ADC0 reference resistor connection pin	—	—	—
109	109	P33	I/O	Input/output port	RT0	O	RC type ADC0 resistor sensor connection pin	—	—	—
107	107	P34	I/O	Input/output port	RCT0	O	RC type ADC0 resistor/capacitor sensor connection pin	PWM0	O	PWM0 output
110	110	P35	I/O	Input/output port	RCM	O	RC type ADC oscillation monitor	PWM1	O	PWM1 output
97	97	P40	I/O	Input/output port	SDA	I/O	I <sup>2</sup> C data input/output	SIN0	I	SSIO data input
98	98	P41	I/O	Input/output port	SCL	I/O	I <sup>2</sup> C clock input/output	SCK0	I/O	SSIO synchronous clock
118	118	P42	I/O	Input/output port	RXD0	I	UART data input	SOUT0	O	SSIO data output
119	119	P43	I/O	Input/output port	TXD0	O	UART data output	PWM0	O	PWM0 output
101	101	P44/T02P0CK	I/O	Input/output port, Timer 0/Timer 2/PWM0 external clock input	IN1	I	RC type ADC1 oscillation input pin	SIN0	I	SSIO0 data input
102	102	P45/T13P1CK	I/O	Input/output port, Timer 1/Timer 3/PWM1 external clock input	CS1	O	RC type ADC1 reference capacitor connection pin	SCK0	I/O	SSIO0 synchronous clock
103	103	P46/T46P2CK	I/O	Input/output port, PWM2 external clock input	RS1	O	RC type ADC1 reference resistor connection pin	SOUT0	O	SSIO0 data output
104	1004	P47	I/O	Input/output port	RT1	O	RC type ADC1 resistor sensor connection pin	PWM1	O	PWM1 output
84	—	PA0	I/O	Input/output port	—	—	—	—	—	—
85	—	PA1	I/O	Input/output port	—	—	—	—	—	—
86	—	PA2	I/O	Input/output port	—	—	—	—	—	—
87	—	PA3	I/O	Input/output port	—	—	—	—	—	—
88	—	PA4	I/O	Input/output port	—	—	—	—	—	—
89	—	PA5	I/O	Input/output port	—	—	—	—	—	—
12	12	COM0	O	LCD common pin	—	—	—	—	—	—
13	13	COM1	O	LCD common pin	—	—	—	—	—	—
14	14	COM2	O	LCD common pin	—	—	—	—	—	—
15	15	COM3	O	LCD common pin	—	—	—	—	—	—
16	16	COM4	O	LCD common pin	—	—	—	—	—	—
17	17	COM5	O	LCD common pin	—	—	—	—	—	—
18	18	COM6	O	LCD common pin	—	—	—	—	—	—
19	19	COM7	O	LCD common pin	—	—	—	—	—	—
—	78	COM8	O	LCD common pin	—	—	—	—	—	—
—	79	COM9	O	LCD common pin	—	—	—	—	—	—
—	80	COM10	O	LCD common pin	—	—	—	—	—	—
—	81	COM11	O	LCD common pin	—	—	—	—	—	—
—	82	COM12	O	LCD common pin	—	—	—	—	—	—
—	83	COM13	O	LCD common pin	—	—	—	—	—	—
—	84	COM14	O	LCD common pin	—	—	—	—	—	—
—	85	COM15	O	LCD common pin	—	—	—	—	—	—

PAD No.		Primary function			Secondary function			Tertiary function		
Q429	Q428	Pin name	I/O	Function	Pin name	I/O	Function	Pin name	I/O	Function
—	86	COM16	O	LCD common pin	—	—	—	—	—	—
—	87	COM17	O	LCD common pin	—	—	—	—	—	—
—	88	COM18	O	LCD common pin	—	—	—	—	—	—
—	89	COM19	O	LCD common pin	—	—	—	—	—	—
—	90	COM20	O	LCD common pin	—	—	—	—	—	—
—	91	COM21	O	LCD common pin	—	—	—	—	—	—
—	92	COM22	O	LCD common pin	—	—	—	—	—	—
—	93	COM23	O	LCD common pin	—	—	—	—	—	—
20	20	SEG0	O	LCD segment pin	—	—	—	—	—	—
21	21	SEG1	O	LCD segment pin	—	—	—	—	—	—
22	22	SEG2	O	LCD segment pin	—	—	—	—	—	—
23	23	SEG3	O	LCD segment pin	—	—	—	—	—	—
24	24	SEG4	O	LCD segment pin	—	—	—	—	—	—
25	25	SEG5	O	LCD segment pin	—	—	—	—	—	—
26	26	SEG6	O	LCD segment pin	—	—	—	—	—	—
27	27	SEG7	O	LCD segment pin	—	—	—	—	—	—
28	28	SEG8	O	LCD segment pin	—	—	—	—	—	—
29	29	SEG9	O	LCD segment pin	—	—	—	—	—	—
30	30	SEG10	O	LCD segment pin	—	—	—	—	—	—
31	31	SEG11	O	LCD segment pin	—	—	—	—	—	—
32	32	SEG12	O	LCD segment pin	—	—	—	—	—	—
33	33	SEG13	O	LCD segment pin	—	—	—	—	—	—
34	34	SEG14	O	LCD segment pin	—	—	—	—	—	—
35	35	SEG15	O	LCD segment pin	—	—	—	—	—	—
36	36	SEG16	O	LCD segment pin	—	—	—	—	—	—
37	37	SEG17	O	LCD segment pin	—	—	—	—	—	—
38	38	SEG18	O	LCD segment pin	—	—	—	—	—	—
39	39	SEG19	O	LCD segment pin	—	—	—	—	—	—
40	40	SEG20	O	LCD segment pin	—	—	—	—	—	—
41	41	SEG21	O	LCD segment pin	—	—	—	—	—	—
42	42	SEG22	O	LCD segment pin	—	—	—	—	—	—
43	43	SEG23	O	LCD segment pin	—	—	—	—	—	—
44	44	SEG24	O	LCD segment pin	—	—	—	—	—	—
45	45	SEG25	O	LCD segment pin	—	—	—	—	—	—
46	46	SEG26	O	LCD segment pin	—	—	—	—	—	—
47	47	SEG27	O	LCD segment pin	—	—	—	—	—	—
48	48	SEG28	O	LCD segment pin	—	—	—	—	—	—
49	49	SEG29	O	LCD segment pin	—	—	—	—	—	—
50	50	SEG30	O	LCD segment pin	—	—	—	—	—	—
51	51	SEG31	O	LCD segment pin	—	—	—	—	—	—
52	52	SEG32	O	LCD segment pin	—	—	—	—	—	—
53	53	SEG33	O	LCD segment pin	—	—	—	—	—	—
54	54	SEG34	O	LCD segment pin	—	—	—	—	—	—
55	55	SEG35	O	LCD segment pin	—	—	—	—	—	—
56	56	SEG36	O	LCD segment pin	—	—	—	—	—	—
57	57	SEG37	O	LCD segment pin	—	—	—	—	—	—
58	58	SEG38	O	LCD segment pin	—	—	—	—	—	—
59	59	SEG39	O	LCD segment pin	—	—	—	—	—	—
60	60	SEG40	O	LCD segment pin	—	—	—	—	—	—
61	61	SEG41	O	LCD segment pin	—	—	—	—	—	—
62	62	SEG42	O	LCD segment pin	—	—	—	—	—	—
63	63	SEG43	O	LCD segment pin	—	—	—	—	—	—
64	64	SEG44	O	LCD segment pin	—	—	—	—	—	—

PAD No.		Primary function			Secondary function			Tertiary function		
Q429	Q428	Pin name	I/O	Function	Pin name	I/O	Function	Pin name	I/O	Function
65	65	SEG45	O	LCD segment pin	—	—	—	—	—	—
66	66	SEG46	O	LCD segment pin	—	—	—	—	—	—
67	67	SEG47	O	LCD segment pin	—	—	—	—	—	—
68	68	SEG48	O	LCD segment pin	—	—	—	—	—	—
69	69	SEG49	O	LCD segment pin	—	—	—	—	—	—
70	70	SEG50	O	LCD segment pin	—	—	—	—	—	—
71	71	SEG51	O	LCD segment pin	—	—	—	—	—	—
72	72	SEG52	O	LCD segment pin	—	—	—	—	—	—
73	73	SEG53	O	LCD segment pin	—	—	—	—	—	—
74	74	SEG54	O	LCD segment pin	—	—	—	—	—	—
75	75	SEG55	O	LCD segment pin	—	—	—	—	—	—
76	76	SEG56	O	LCD segment pin	—	—	—	—	—	—
77	77	SEG57	O	LCD segment pin	—	—	—	—	—	—
78	—	SEG58	O	LCD segment pin	—	—	—	—	—	—
79	—	SEG59	O	LCD segment pin	—	—	—	—	—	—
80	—	SEG60	O	LCD segment pin	—	—	—	—	—	—
81	—	SEG61	O	LCD segment pin	—	—	—	—	—	—
82	—	SEG62	O	LCD segment pin	—	—	—	—	—	—
83	—	SEG63	O	LCD segment pin	—	—	—	—	—	—

## PIN DESCRIPTION

Pin name	I/O	Description	Primary/ Secondary/ Tertiary	Logic
<b>System</b>				
RESET_N	I	Reset input pin. When this pin is set to a "L" level, system reset mode is set and the internal section is initialized. When this pin is set to a "H" level subsequently, program execution starts. A pull-up resistor is internally connected.	—	Negative
XT0	I	Crystal connection pin for low-speed clock.	—	—
XT1	O	A 32.768 kHz crystal oscillator (see measuring circuit 1) is connected to this pin. Capacitors CDL and CGL are connected across this pin and V <sub>SS</sub> as required.	—	—
OSC0	I	Crystal/ceramic connection pin for high-speed clock.	Secondary	—
OSC1	O	A crystal or ceramic is connected to this pin (4.1 MHz max.). Capacitors CDH and CGH (see measuring circuit 1) are connected across this pin and V <sub>SS</sub> . This pin is used as the secondary function of the P10 pin(OSC0) and P11 pin(OSC1).	Secondary	—
LSCLK	O	Low-speed clock output pin. This pin is used as the secondary function of the P20 pin.	Secondary	—
OUTCLK	O	High-speed clock output pin. This pin is used as the secondary function of the P21 pin.	Secondary	—
<b>General-purpose input port</b>				
P00-P03	I	General-purpose input port. Since these pins have secondary functions, the pins cannot be used as a port when the secondary functions are used.	Primary	Positive
P04-P07	I	General-purpose input port. Since these pins have secondary functions, the pins cannot be used as a port when the secondary functions are used. These pins are for the ML610Q429, but are not provided in the ML610Q428.	Primary	Positive
P10-P11	I	General-purpose input port. Since these pins have secondary functions, the pins cannot be used as a port when the secondary functions are used.	Primary	Positive
<b>General-purpose output port</b>				
P20-P22	O	General-purpose output port. Since these pins have secondary functions, the pins cannot be used as a port when the secondary functions are used.	Primary	Positive
<b>General-purpose input/output port</b>				
P30-P35	I/O	General-purpose input/output port. Since these pins have secondary functions, the pins cannot be used as a port when the secondary functions are used.	Primary	Positive
P40-P47	I/O	General-purpose input/output port. Since these pins have secondary functions, the pins cannot be used as a port when the secondary functions are used.	Primary	Positive
PA0-PA5	I/O	General-purpose input/output port. These pins are for the ML610Q429, but are not provided in the ML610Q428.	Primary	Positive

Pin name	I/O	Description	Primary/ Secondary/ Tertiary	Logic
<b>UART</b>				
TXD0	O	UART data output pin. This pin is used as the secondary function of the P43 pin.	Secondary	Positive
RXD0	I	UART data input pin. This pin is used as the secondary function of the P42 or the primary function of the P02 pin.	Primary/Secondary	Positive
<b>I<sup>2</sup>C bus interface</b>				
SDA	I/O	I <sup>2</sup> C data input/output pin. This pin is used as the secondary function of the P40 pin. This pin has an NMOS open drain output. When using this pin as a function of the I <sup>2</sup> C, externally connect a pull-up resistor.	Secondary	Positive
SCL	O	I <sup>2</sup> C clock output pin. This pin is used as the secondary function of the P41 pin. This pin has an NMOS open drain output. When using this pin as a function of the I <sup>2</sup> C, externally connect a pull-up resistor.	Secondary	Positive
<b>Synchronous serial (SSIO)</b>				
SCK0	I/O	Synchronous serial clock input/output pin. This pin is used as the tertiary function of the P41 or P45 pin.	Tertiary	—
SIN0	I	Synchronous serial data input pin. This pin is used as the tertiary function of the P40 or P44 pin.	Tertiary	Positive
SOUT0	O	Synchronous serial data output pin. This pin is used as the tertiary function of the P42 or P46 pin.	Tertiary	Positive
<b>PWM</b>				
PWM0	O	PWM0 output pin. This pin is used as the tertiary function of the P43 or P34 pin.	Tertiary	Positive
T0P0CK	I	PWM0 external clock input pin. This pin is used as the primary function of the P44 pin.	Primary	—
PWM1	O	PWM1 output pin. This pin is used as the tertiary function of the P47 or P35 pin.	Tertiary	Positive
T1P1CK	I	PWM1 external clock input pin. This pin is used as the primary function of the P45 pin.	Primary	—
PWM2	O	PWM2 output pin. This pin is used as the tertiary function of the P20 or P30 pin.	Tertiary	Positive
P2CK	I	PWM2 external clock input pin. This pin is used as the primary function of the P02 pin.	Primary	—
<b>External interrupt</b>				
NMI	I	External non-maskable interrupt input pin. An interrupt is generated on both edges.	Primary	Positive/negative
EXI0-7	I	External maskable interrupt input pins. Interrupt enable and edge selection can be performed for each bit by software. These pins are used as the primary functions of the P00-P07 pins.	Primary	Positive/negative
<b>Timer</b>				
T0P0CK	I	External clock input pin used for Timer 0. This pin is used as the primary function of the P44 pin.	Primary	—
T1P1CK	I	External clock input pin used for Timer 1. This pin is used as the primary function of the P45 pin.	Primary	—
<b>Melody</b>				
MD0	O	Melody/buzzer signal output pin. This pin is used as the secondary function of the P22 pin.	Secondary	Positive/negative
<b>LED drive</b>				
LED0-2	O	Nch open drain output pins to drive LED.	Primary	Positive/negative

Pin name	I/O	Description	Primary/ Secondary/ Tertiary	Logic
<b>RC oscillation type A/D converter</b>				
IN0	I	Channel 0 oscillation input pin. This pin is used as the secondary function of the P30 pin.	Secondary	—
CS0	O	Channel 0 reference capacitor connection pin. This pin is used as the secondary function of the P31 pin.	Secondary	—
RS0	O	This pin is used as the secondary function of the P32 pin which is the reference resistor connection pin of Channel 0.	Secondary	—
RT0	O	Resistor sensor connection pin of Channel 0 for measurement. This pin is used as the secondary function of the P34 pin.	Secondary	—
CRT0	O	Resistor/capacitor sensor connection pin of Channel 0 for measurement. This pin is used as the secondary function of the P33 pin.	Secondary	—
RCM	O	RC oscillation monitor pin. This pin is used as the secondary function of the P35 pin.	Secondary	—
IN1	I	Oscillation input pin of Channel 1. This pin is used as the secondary function of the P44 pin.	Secondary	—
CS1	O	Reference capacitor connection pin of Channel 1. This pin is used as the secondary function of the P45 pin.	Secondary	—
RS1	O	Reference resistor connection pin of Channel 1. This pin is used as the secondary function of the P46 pin.	Secondary	—
RT1	O	Resistor sensor connection pin for measurement of Channel 1. This pin is used as the secondary function of the P47 pin.	Secondary	—
<b>LCD drive signal</b>				
COM0-7	O	Common output pins.	—	—
COM8-23	O	Common output pins. These pins are for the ML610Q428, but are not provided in the ML610Q429.	—	—
SEG0-57	O	Segment output pin.	—	—
SEG58-63	O	Segment output pins. These pins are for the ML610Q429, but are not provided in the ML610Q428.	—	—
<b>LCD driver power supply</b>				
V <sub>L1</sub>	—	Power supply pins for LCD bias (internally generated). Capacitors Ca, Cb, Cc, and Cd (see measuring circuit 1) are connected between V <sub>SS</sub> and V <sub>L1</sub> , V <sub>L2</sub> , V <sub>L3</sub> , and V <sub>L4</sub> , respectively.	—	—
V <sub>L2</sub>	—		—	—
V <sub>L3</sub>	—		—	—
V <sub>L4</sub>	—		—	—
C1	—	Power supply pins for LCD bias (internally generated). Capacitors C12 and C34 (see measuring circuit 1) are connected between C1 and C2 and between C3 and C4, respectively.	—	—
C2	—		—	—
C3	—		—	—
C4	—		—	—
<b>For testing</b>				
TEST	I/O	Input/output pin for testing. A pull-down resistor is internally connected.	—	—
<b>Power supply</b>				
V <sub>SS</sub>	—	Negative power supply pin.	—	—
V <sub>DD</sub>	—	Positive power supply pin.	—	—
V <sub>DDL</sub>	—	Positive power supply pin (internally generated) for internal logic. Capacitors CL0 and CL1 (see measuring circuit 1) are connected between this pin and V <sub>SS</sub> .	—	—
V <sub>DDX</sub>	—	Plus-side power supply pin (internally generated) for low-speed oscillation. Capacitor Cx (see measuring circuit 1) is connected between this pin and V <sub>SS</sub> .	—	—
V <sub>PP</sub>	—	Power supply pin for programming Flash ROM. A pull-up resistor is internally connected.	—	—



## TERMINATION OF UNUSED PINS

Table 3 shows methods of terminating the unused pins.

**Table 3 Termination of Unused Pins**

Pin	Recommended pin termination
V <sub>PP</sub>	Open
V <sub>L1</sub> , V <sub>L2</sub> , V <sub>L3</sub> , V <sub>L4</sub>	Open
C1, C2, C3, C4	Open
RESET_N	Open
TEST	Open
NMI	Open
P00 to P07	V <sub>DD</sub> or V <sub>SS</sub>
P10 to P11	V <sub>DD</sub>
P20 to P22	Open
P30 to P35	Open
P40 to P47	Open
PA0 to PA5	Open
COM0 to 23	Open
SEG0 to 63	Open

**Note:**

It is recommended to set the unused input ports and input/output ports to the inputs with pull-down resistors/pull-up resistors or the output mode since the supply current may become excessively large if the pins are left open in the high impedance input setting.

The main difference points of ML610Q428 and ML610Q429

**Table 4 The main difference points of ML610Q428 and ML610Q429.**

Function	ML610Q428	ML610Q429
PORT0	P03 to P00	P07 to P00
PORTA	Nothing	PA5 to PA0
LCD COM	COM23 to COM0	COM7 to COM0
LCD SEG	SEG57 to SEG0	SEG63 to SEG0

**ELECTRICAL CHARACTERISTICS****ABSOLUTE MAXIMUM RATINGS**(V<sub>SS</sub> = 0V)

Parameter	Symbol	Condition	Rating	Unit
Power supply voltage 1	V <sub>DD</sub>	Ta = 25°C	-0.3 to +4.6	V
Power supply voltage 2	V <sub>PP</sub>	Ta = 25°C	-0.3 to +9.5	V
Power supply voltage 3	V <sub>DDL</sub>	Ta = 25°C	-0.3 to +3.6	V
Power supply voltage 4	V <sub>DDX</sub>	Ta = 25°C	-0.3 to +3.6	V
Power supply voltage 5	V <sub>L1</sub>	Ta = 25°C	-0.3 to +1.75	V
Power supply voltage 6	V <sub>L2</sub>	Ta = 25°C	-0.3 to +3.5	V
Power supply voltage 7	V <sub>L3</sub>	Ta = 25°C	-0.3 to +5.25	V
Power supply voltage 8	V <sub>L4</sub>	Ta = 25°C	-0.3 to +7.0	V
Input voltage	V <sub>IN</sub>	Ta = 25°C	-0.3 to V <sub>DD</sub> +0.3	V
Output voltage	V <sub>OUT</sub>	Ta = 25°C	-0.3 to V <sub>DD</sub> +0.3	V
Output current 1	I <sub>OUT1</sub>	Port3-A, Ta = 25°C	-12 to +11	mA
Output current 2	I <sub>OUT2</sub>	Port2, Ta = 25°C	-12 to +20	mA
Power dissipation	PD	Ta = 25°C	122	mW
Storage temperature	T <sub>STG</sub>	—	-55 to +150	°C

**RECOMMENDED OPERATING CONDITIONS**(V<sub>SS</sub> = 0V)

Parameter	Symbol	Condition	Range	Unit
Operating temperature	T <sub>OP</sub>	—	-20 to +70	°C
Operating voltage	V <sub>DD</sub>	—	1.1 to 3.6	V
Operating frequency (CPU)	f <sub>OP</sub>	V <sub>DD</sub> = 1.1 to 3.6V	30k to 36k	Hz
		V <sub>DD</sub> = 1.3 to 3.6V	30k to 650k	
		V <sub>DD</sub> = 1.8 to 3.6V	30k to 4.2M	
Low-speed crystal oscillation frequency	f <sub>XTL</sub>	—	32.768k	Hz
Low-speed crystal oscillation external capacitor	C <sub>DL</sub>	—	0 to 12	pF
	C <sub>GL</sub>	—	0 to 12	
High-speed crystal/ceramic oscillation frequency	f <sub>XTH</sub>	—	4.0M / 4.096M	Hz
High-speed crystal oscillation external capacitor	C <sub>DH</sub>	—	24	pF
	C <sub>GH</sub>	—	24	
Capacitor externally connected to V <sub>DDL</sub> pin	C <sub>L0</sub>	—	1.0±30%	μF
	C <sub>L1</sub>	—	0.1±30%	
Capacitor externally connected to V <sub>DDX</sub> pin	C <sub>X</sub>	—	0.1±30%	μF
Capacitors externally connected to V <sub>L1, 2, 3, 4</sub> pins	C <sub>a, b, c, d</sub>	—	1.0±30%	μF
Capacitors externally connected across C1 and C2 pins and across C3 and C4 pins	C <sub>12, C34</sub>	—	1.0±30%	μF

## OPERATING CONDITIONS OF FLASH ROM

(V<sub>SS</sub> = 0V)

Parameter	Symbol	Condition	Range	Unit
Operating temperature	T <sub>OP</sub>	At write/erase	0 to +40	°C
Operating voltage	V <sub>DD</sub>	At write/erase <sup>*1</sup>	2.75 to 3.6	V
	V <sub>DDL</sub>	At write/erase <sup>*1</sup>	2.5 to 2.75	
	V <sub>PP</sub>	At write/erase <sup>*1</sup>	7.7 to 8.3	
Write cycles	C <sub>EP</sub>	—	80	cycles
Data retention	Y <sub>DR</sub>	—	10	years

<sup>\*1</sup>: In addition the power supply to VDD pin and VPP pin, within the range 2.5V to 2.75V has to be supplied to VDDL pin when programming and erasing Flash ROM.

## DC CHARACTERISTICS (1/5)

(V<sub>DD</sub> = 1.1 to 3.6V, V<sub>SS</sub> = 0V, Ta = -20 to +70°C, unless otherwise specified) (1/5)

Parameter	Symbol	Condition	Rating			Unit	Measuring circuit
			Min.	Typ.	Max.		
500kHz RC oscillation frequency	f <sub>RC</sub>	V <sub>DD</sub> = 1.3 to 3.6V	Ta = 25°C	Typ. -10%	500	Typ. +10%	kHz
			Ta = -20 to +70°C	Typ. -25%	500	Typ. +25%	
PLL oscillation frequency <sup>*4</sup>	f <sub>PLL</sub>	LSCLK = 32.768kHz V <sub>DD</sub> = 1.8 to 3.6V	-2.5%	8.192	+2.5%	MHz	1
Low-speed crystal oscillation start time <sup>*2</sup>	T <sub>XTL</sub>	—	—	0.3	2	s	
500kHz RC oscillation start time	T <sub>RC</sub>	—	—	50	500	μs	
High-speed crystal oscillation start time <sup>*3</sup>	T <sub>XTH</sub>	V <sub>DD</sub> = 1.8 to 3.6V	—	2	20	ms	
PLL oscillation start time	T <sub>PLL</sub>	V <sub>DD</sub> = 1.8 to 3.6V	—	1	10		
Low-speed oscillation stop detect time <sup>*1</sup>	T <sub>STOP</sub>	—	0.2	3	20	μs	
Reset pulse width	P <sub>RST</sub>	—	200	—	—		
Reset noise elimination pulse width	P <sub>NRST</sub>	—	—	—	0.3	ms	
Power-on reset activation power rise time	T <sub>POR</sub>	—	—	—	10		

<sup>\*1</sup>: When low-speed crystal oscillation stops for a duration more than the low-speed oscillation stop detect time, the system is reset to shift to system reset mode.

<sup>\*2</sup>: Use 32.768kHz crystal resonator DT-26 (Load capacitance 6pF) (made by KDS:DAISHINKU CORP.) is used (C<sub>GL</sub>=C<sub>DL</sub>=12pF).

<sup>\*3</sup>: Use 4.096MHz Crystal Oscillator CHC49SFWB (Kyocera).

<sup>\*4</sup>: 1024 clock average.

## RESET

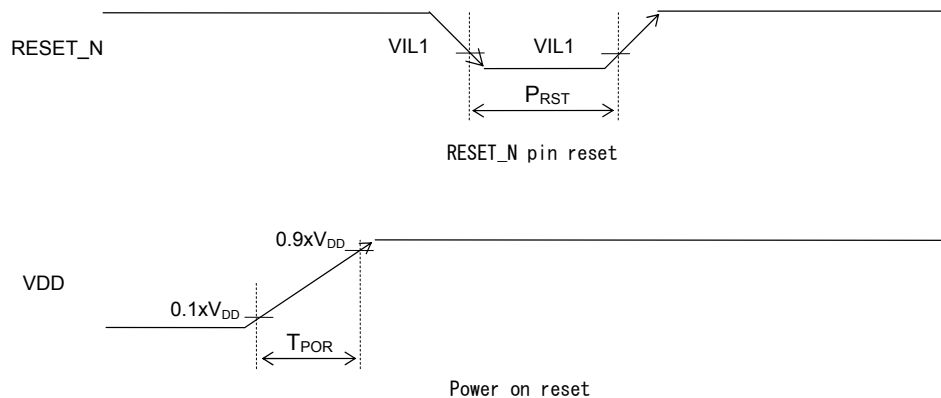

## DC CHARACTERISTICS (2/5)

(V<sub>DD</sub> = 1.1 to 3.6V, V<sub>SS</sub> = 0V, Ta = -20 to +70°C, unless otherwise specified) (2/5)

Parameter	Symbol	Condition	Rating			Unit	Measuring circuit	
			Min.	Typ.	Max.			
V <sub>L1</sub> voltage	V <sub>L1</sub>	V <sub>DD</sub> = 3.0V, T <sub>j</sub> = 25°C	CN4-0 = 00H	0.89	0.94	0.99	V	1
			CN4-0 = 01H	0.91	0.96	1.01		
			CN4-0 = 02H	0.93	0.98	1.03		
			CN4-0 = 03H	0.95	1.00	1.05		
			CN4-0 = 04H	0.97	1.02	1.07		
			CN4-0 = 05H	0.99	1.04	1.09		
			CN4-0 = 06H	1.01	1.06	1.11		
			CN4-0 = 07H	1.03	1.08	1.13		
			CN4-0 = 08H	1.05	1.10	1.15		
			CN4-0 = 09H	1.07	1.12	1.17		
			CN4-0 = 0AH	1.09	1.14	1.19		
			CN4-0 = 0BH	1.11	1.16	1.21		
			CN4-0 = 0CH	1.13	1.18	1.23		
			CN4-0 = 0DH	1.15	1.20	1.25		
			CN4-0 = 0EH	1.17	1.22	1.27		
			CN4-0 = 0FH	1.19	1.24	1.29		
			CN4-0 = 10H	1.21	1.26	1.31		
			CN4-0 = 11H	1.23	1.28	1.33		
			CN4-0 = 12H	1.25	1.30	1.35		
			CN4-0 = 13H	1.27	1.32	1.37		
			CN4-0 = 14H <sup>*1</sup>	1.29	1.34	1.39		
			CN4-0 = 15H <sup>*1</sup>	1.31	1.36	1.41		
			CN4-0 = 16H <sup>*1</sup>	1.33	1.38	1.43		
			CN4-0 = 17H <sup>*1</sup>	1.35	1.40	1.45		
CN4-0 = 18H <sup>*1</sup>	1.37	1.42	1.47					
CN4-0 = 19H <sup>*1</sup>	1.39	1.44	1.49					
CN4-0 = 1AH <sup>*1</sup>	1.41	1.46	1.51					
CN4-0 = 1BH <sup>*1</sup>	1.43	1.48	1.53					
CN4-0 = 1CH <sup>*1</sup>	1.45	1.50	1.55					
CN4-0 = 1DH <sup>*1</sup>	1.47	1.52	1.57					
CN4-0 = 1EH <sup>*1</sup>	1.49	1.54	1.59					
CN4-0 = 1FH <sup>*1</sup>	1.51	1.56	1.61					
V <sub>L1</sub> temperature deviation	ΔV <sub>L1</sub>	V <sub>DD</sub> = 3.0V	—	-1.5	—	mV/°C		
V <sub>L1</sub> voltage dependency	ΔV <sub>L1</sub>	V <sub>DD</sub> = 1.3 to 3.6V	—	5	20	mV/V		
V <sub>L2</sub> voltage	V <sub>L2</sub>	V <sub>DD</sub> = 3.0V, T <sub>j</sub> = 25°C 300kΩ load (V <sub>L4</sub> -V <sub>SS</sub> )	Typ. -10%	V <sub>L1</sub> ×2	Typ. +4%	V		
V <sub>L3</sub> voltage	V <sub>L3</sub>	V <sub>DD</sub> = 3.0V, T <sub>j</sub> = 25°C 300kΩ load (V <sub>L4</sub> -V <sub>SS</sub> )	1/3 bias	Typ. -10%	V <sub>L1</sub> ×2		Typ. +4%	
V <sub>L3</sub> voltage	V <sub>L3</sub>		1/4 bias	Typ. -10%	V <sub>L1</sub> ×3		Typ. +4%	
V <sub>L4</sub> voltage	V <sub>L4</sub>		1/3 bias	Typ. -10%	V <sub>L1</sub> ×3		Typ. +5%	
V <sub>L4</sub> voltage	V <sub>L4</sub>		1/4 bias	Typ. -10%	V <sub>L1</sub> ×4	Typ. +5%		
LCD bias voltage generation time	T <sub>BIAS</sub>	—	—	—	600	ms		

\*1: When using 1/4 bias, the V<sub>L1</sub> voltage is set to typ. 1.32 V (same voltage as in CN4-0 = 13H).

## DC CHARACTERISTICS (3/5)

(V<sub>DD</sub> = 1.1 to 3.6V, V<sub>SS</sub> = 0V, Ta = -20 to +70°C, unless otherwise specified) (3/5)

Parameter	Symbol	Condition		Rating			Unit	Measuring circuit
				Min.	Typ.	Max.		
BLD threshold voltage	V <sub>BLD</sub>	V <sub>DD</sub> = 1.35 to 3.6V		LD2-0 = 0H	Typ. -2%	1.35	Typ. +2%	V
				LD2-0 = 1H		1.4		
				LD2-0 = 2H		1.45		
				LD2-0 = 3H		1.5		
				LD2-0 = 4H		1.6		
				LD2-0 = 5H		1.7		
				LD2-0 = 6H		1.8		
				LD2-0 = 7H		1.9		
				LD2-0 = 8H		2.0		
				LD2-0 = 9H		2.1		
				LD2-0 = 0AH		2.2		
				LD2-0 = 0BH		2.3		
				LD2-0 = 0CH		2.4		
				LD2-0 = 0DH		2.5		
LD2-0 = 0EH	2.7							
LD2-0 = 0FH	2.9							
BLD threshold voltage temperature deviation	ΔV <sub>BLD</sub>	V <sub>DD</sub> = 1.35 to 3.6V		—	0	—	%/°C	1
Supply current 1	IDD1	CPU: In STOP state. Low-speed/high-speed oscillation: stopped.	Ta = 25°C	—	0.15	0.50	μA	
			Ta = -20 to +70°C	—	—	2.50		
Supply current 2	IDD2	CPU: In HALT state (LTBC, RTC: Operating <sup>*3*</sup> ).	Ta = 25°C	—	0.5	1.3	μA	
		High-speed oscillation: Stopped. LCD/BIAS circuits: Stopped.	Ta = -20 to +70°C	—	—	3.5		
Supply current 3	IDD3	CPU: In 32.768kHz operating state. <sup>*1*</sup>	Ta = 25°C	—	5	7	μA	
		High-speed oscillation: Stopped. LCD/BIAS circuits: Operating. <sup>*2*</sup>	Ta = -20 to +70°C	—	—	12		
Supply current 4	IDD4	CPU: In 500kHz CR operating state. LCD/BIAS circuits: Operating. <sup>*2*</sup>	Ta = 25°C	—	70	85	μA	
			Ta = -20 to +70°C	—	—	100		
Supply current 5	IDD5	CPU: In 2MHz CR operating state. LCD/BIAS circuits: Operating. <sup>*2*</sup>	Ta = 25°C	—	0.4	0.5	mA	
			Ta = -20 to +70°C	—	—	0.6		
Supply current 6	IDD6	CPU: In 4.096MHz operating state. PLL: In oscillating state. LCD/BIAS circuits: Operating. <sup>*2*</sup>	Ta = 25°C	—	0.8	1.0	mA	
		V <sub>DD</sub> = 1.8 to 3.6V	Ta = -20 to +70°C	—	—	1.2		

\*1: CPU operating rate is 100% (No HALT state).

\*2: All SEGs: off waveform, No LCD panel load, 1/3 bias, 1/3 duty, Frame frequency: Approx. 64 Hz,  
Bias voltage multiplying clock: 1/128 LSCLK (256Hz)\*3: Use 32.768kHz crystal resonator DT-26 (Load capacitance 6pF) (made by KDS:DAISHINKU CORP.) is used (C<sub>GL</sub>=C<sub>DL</sub>=6pF).

\*4: Use 4.096MHz Crystal Oscillator CHC49SFWB (Kyocera).

\*5: Significant bits of BLKCON0~BLKCON4 registers are all "1".

## DC CHARACTERISTICS (4/5)

(V<sub>DD</sub> = 1.1 to 3.6V, V<sub>SS</sub> = 0V, Ta = -20 to +70°C, unless otherwise specified) (4/5)

Parameter	Symbol	Condition	Rating			Unit	Measuring circuit	
			Min.	Typ.	Max.			
Output voltage 1 (P20–P22/2 <sup>nd</sup> function is selected) (P30–P36) (P40–P47) (PA0–PA5) <sup>*1</sup>	VOH1	IOH1 = -0.5mA, V <sub>DD</sub> = 1.8 to 3.6V	V <sub>DD</sub> -0.5	—	—	V	2	
		IOH1 = -0.1mA, V <sub>DD</sub> = 1.3 to 3.6V	V <sub>DD</sub> -0.3	—	—			
		IOH1 = -0.03mA, V <sub>DD</sub> = 1.1 to 3.6V	V <sub>DD</sub> -0.3	—	—			
	VOL1	IOL1 = +0.5mA, V <sub>DD</sub> = 1.8 to 3.6V	—	—	0.5			
		IOL1 = +0.1mA, V <sub>DD</sub> = 1.3 to 3.6V	—	—	0.5			
		IOL1 = +0.03mA, V <sub>DD</sub> = 1.1 to 3.6V	—	—	0.3			
Output voltage 2 (P20–P22/2 <sup>nd</sup> function is Not selected)	VOH2	IOH1 = -0.5mA, V <sub>DD</sub> = 1.8 to 3.6V	V <sub>DD</sub> -0.5	—	—			
		IOH1 = -0.1mA, V <sub>DD</sub> = 1.3 to 3.6V	V <sub>DD</sub> -0.3	—	—			
		IOH1 = -0.03mA, V <sub>DD</sub> = 1.1 to 3.6V	V <sub>DD</sub> -0.3	—	—			
	VOL2	IOL2 = +5mA, V <sub>DD</sub> = 1.8 to 3.6V	—	—	0.5			
Output voltage 3 (P40–P41)	VOL3	IOL3 = +3mA, V <sub>DD</sub> = 2.0 to 3.6V (when I <sup>2</sup> C mode is selected)	—	—	0.4			
Output voltage 4 (COM0–23) (SEG0–63)	VOH4	IOH4 = -0.2mA, VL1=1.2V	V <sub>L4</sub> -0.2	—	—			
	VOMH4	IOMH4 = +0.2mA, VL1=1.2V	—	—	V <sub>L3</sub> +0.2			
	VOMH4S	IOMH4S = -0.2mA, VL1=1.2V	V <sub>L3</sub> -0.2	—	—			
	VOM4	IOM4 = +0.2mA, VL1=1.2V	—	—	V <sub>L2</sub> +0.2			
	VOM4S	IOM4S = -0.2mA, VL1=1.2V	V <sub>L2</sub> -0.2	—	—			
	VOML4	IOML4 = +0.2mA, VL1=1.2V	—	—	V <sub>L1</sub> +0.2			
	VOML4S	IOML4S = -0.2mA, VL1=1.2V	V <sub>L1</sub> -0.2	—	—			
	VOL4	IOL4 = +0.2mA, VL1=1.2V	—	—	0.2			
Output leakage (P20–P22) (P30–P35) (P40–P47) (PA0–PA5) <sup>*1</sup>	IOOH	VOH = V <sub>DD</sub> (in high-impedance state)	—	—	1	μA	3	
	IOOL	VOL = V <sub>SS</sub> (in high-impedance state)	-1	—	—			
Input current 1 (RESET_N)	IIH1	VIH1 = V <sub>DD</sub>	0	—	1	μA	4	
	IIL1	VIL1 = V <sub>SS</sub>	V <sub>DD</sub> = 1.8 to 3.6V	-600	-300			-20
			V <sub>DD</sub> = 1.3 to 3.6V	-600	-300			-10
			V <sub>DD</sub> = 1.1 to 3.6V	-600	-300			-2
Input current 1 (TEST)	IIH1	VIH1 = V <sub>DD</sub>	V <sub>DD</sub> = 1.8 to 3.6V	20	300	600		
			V <sub>DD</sub> = 1.3 to 3.6V	10	300	600		
			V <sub>DD</sub> = 1.1 to 3.6V	2	300	600		
	IIL1	VIL1 = V <sub>SS</sub>	-1	—	—			
Input current 2 (NMI) (P00–P03) (P04–P07) <sup>*1</sup> (P10–P11)	IIH2	VIH2 = V <sub>DD</sub> (when pulled-down)	V <sub>DD</sub> = 1.8 to 3.6V	2	30	200		
			V <sub>DD</sub> = 1.3 to 3.6V	0.2	30	200		
			V <sub>DD</sub> = 1.1 to 3.6V	0.01	30	200		
	IIL2	VIL2 = V <sub>SS</sub> (when pulled-up)	V <sub>DD</sub> = 1.8 to 3.6V	-200	-30	-2		
			V <sub>DD</sub> = 1.3 to 3.6V	-200	-30	-0.2		

(P30–P35) (P40–P47) (PA0–PA5) <sup>*1</sup>		$V_{DD} = 1.1 \text{ to } 3.6\text{V}$	–200	–30	–0.01		
	I <sub>IH2Z</sub>	$V_{IH2} = V_{DD}$ (in high-impedance state)	—	—	1		
	I <sub>IL2Z</sub>	$V_{IL2} = V_{SS}$ (in high-impedance state)	–1	—	—		

\*1: ML610Q429 only

**DC CHARACTERISTICS (5/5)** $(V_{DD} = 1.1 \text{ to } 3.6\text{V}, V_{SS} = 0\text{V}, T_a = -20 \text{ to } +70^\circ\text{C}, \text{ unless otherwise specified}) (5/5)$ 

Parameter	Symbol	Condition	Rating			Unit	Measuring circuit
			Min.	Typ.	Max.		
Input voltage 1 (RESET_N) (TEST) (NMI) (P00–P03) (P04–P07) <sup>*1</sup> (P10–P11) (P31–P35) (P40–P43) (P45–P47) (PA0–PA5) <sup>*1</sup>	VIH1	$V_{DD} = 1.3 \text{ to } 3.6\text{V}$	0.7 $\times V_{DD}$	—	$V_{DD}$	V	5
		$V_{DD} = 1.1 \text{ to } 3.6\text{V}$	0.7 $\times V_{DD}$	—	$V_{DD}$		
	VIL1	$V_{DD} = 1.3 \text{ to } 3.6\text{V}$	0	—	0.3 $\times V_{DD}$		
		$V_{DD} = 1.1 \text{ to } 3.6\text{V}$	0	—	0.2 $\times V_{DD}$		
Input voltage 2 (P30, P44)	VIH2	—	0.7 $\times V_{DD}$	—	$V_{DD}$		
	VIL2	—	0	—	0.3 $\times V_{DD}$		
Input pin capacitance (NMI) (P00–P03) (P04–P07) <sup>*1</sup> (P10–P11) (P30–P35) (P40–P47) (PA0–PA5) <sup>*1</sup>	CIN	$f = 10\text{kHz}$ $V_{rms} = 50\text{mV}$ $T_a = 25^\circ\text{C}$	—	—	5	pF	—

\*1: ML610Q429 only

MEASURING CIRCUITS

MEASURING CIRCUIT 1

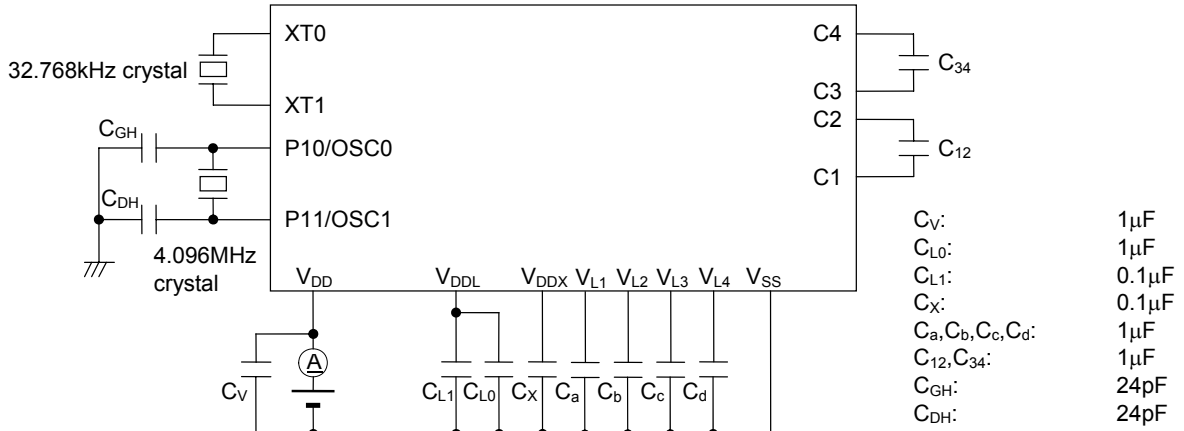

32.768kHz crystal resonator  
DT-26 (Load capacitance 6pF)  
(Made by KDS:DAISHINKU CORP.)

4.096MHz crystal:  
HC49SFWB (Kyocera)

MEASURING CIRCUIT 2

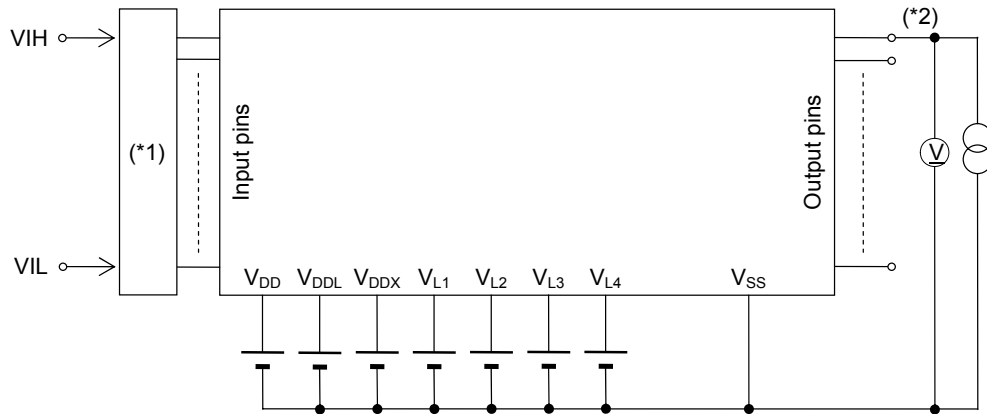

(\*1) Input logic circuit to determine the specified measuring conditions.  
(\*2) Measured at the specified output pins.



**MEASURING CIRCUIT 3**

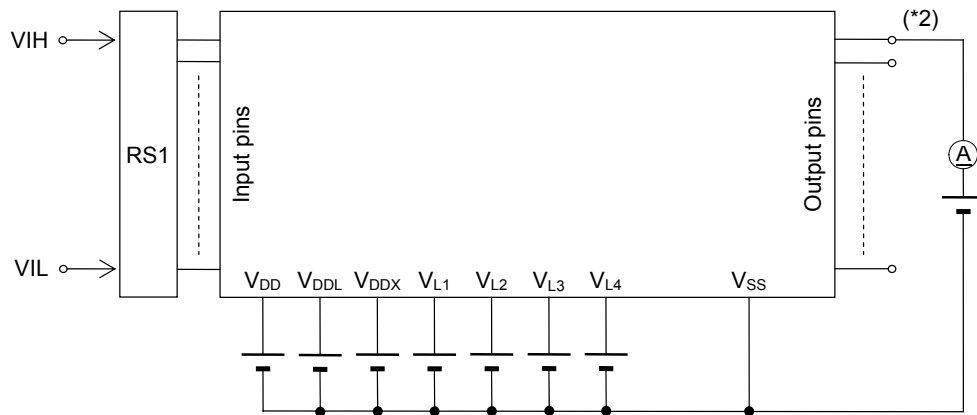

- \*1: Input logic circuit to determine the specified measuring conditions.
- \*2: Measured at the specified output pins.

**MEASURING CIRCUIT 4**

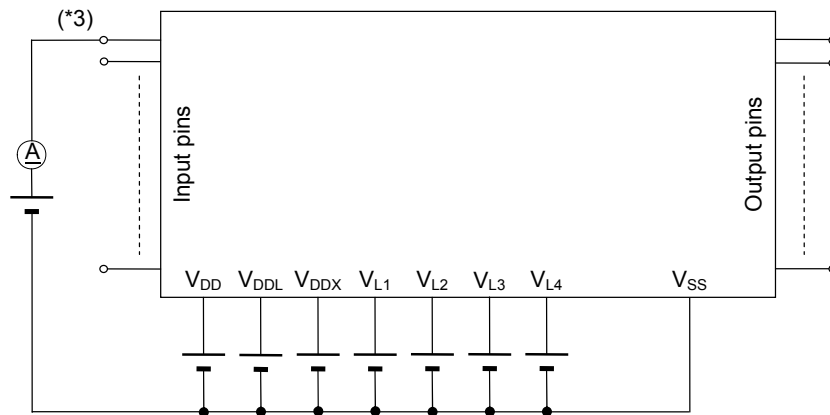

- \*3: Measured at the specified output pins.

**MEASURING CIRCUIT 5**

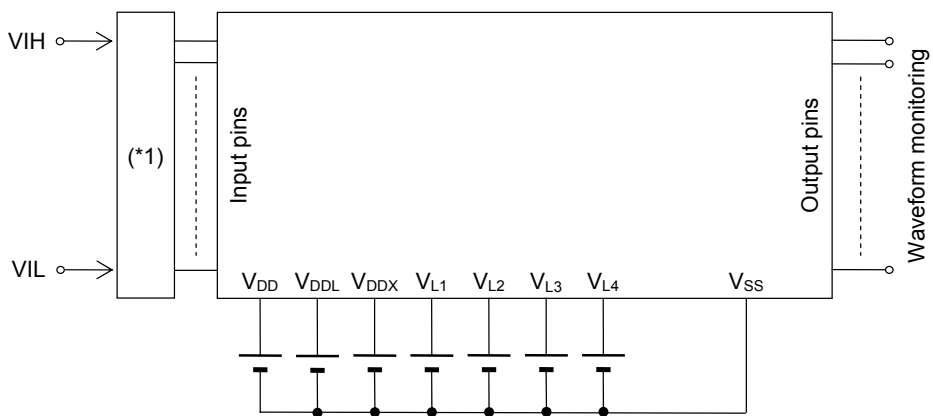

- \*1: Input logic circuit to determine the specified measuring conditions.

**AC CHARACTERISTICS (External Interrupt)**(V<sub>DD</sub> = 1.1 to 3.6V, V<sub>SS</sub> = 0V, Ta = -20 to +70°C, unless otherwise specified)

Parameter	Symbol	Condition	Rating			Unit
			Min.	Typ.	Max.	
External interrupt disable period	T <sub>NUL</sub>	Interrupt: Enabled (MIE = 1), CPU: NOP operation System clock: 32.768kHz	76.8	—	106.8	μs

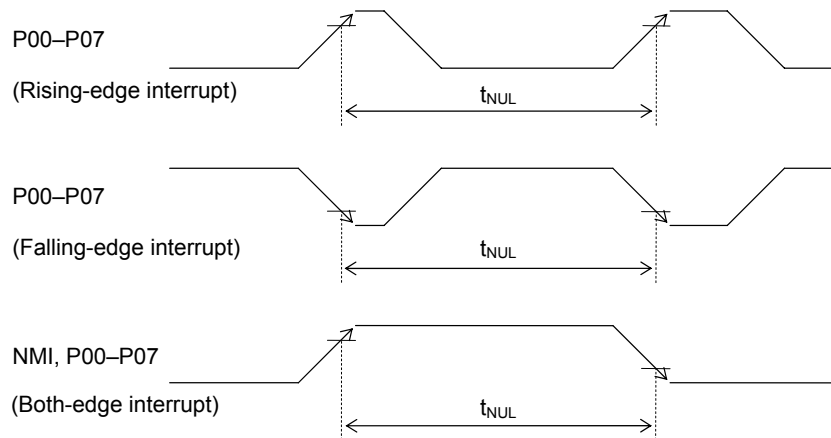
**AC CHARACTERISTICS (UART)**(V<sub>DD</sub> = 1.3 to 3.6V, V<sub>SS</sub> = 0V, Ta = -20 to +70°C, unless otherwise specified)

Parameter	Symbol	Condition	Rating			Unit
			Min.	Typ.	Max.	
Transmit baud rate	t <sub>BRT</sub>	—	—	BRT* <sup>1</sup>	—	s
Receive baud rate	t <sub>RBRT</sub>	—	BRT* <sup>1</sup> -3%	BRT* <sup>1</sup>	BRT* <sup>1</sup> +3%	s

\*1: Baud rate period (including the error of the clock frequency selected) set with the UART baud rate register (UA0BRTL,H) and the UART mode register 0 (UA0MOD0).

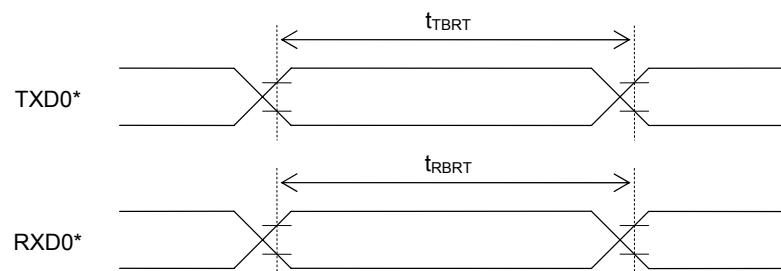

\*: Indicates the secondary function of the port.

**AC CHARACTERISTICS (Synchronous Serial Port)**(V<sub>DD</sub> = 1.3 to 3.6V, V<sub>SS</sub> = 0V, Ta = -20 to +70°C, unless otherwise specified)

Parameter	Symbol	Condition	Rating			Unit
			Min.	Typ.	Max.	
SCLK input cycle (slave mode)	t <sub>SCYC</sub>	When high-speed oscillation is not active	10	—	—	μs
		When high-speed oscillation is active (V <sub>DD</sub> = 1.8 to 3.6V)	1	—	—	μs
SCLK output cycle (master mode)	t <sub>SCYC</sub>	—	—	SCLK* <sup>1</sup>	—	s
SCLK input pulse width (slave mode)	t <sub>SW</sub>	When high-speed oscillation is not active	4	—	—	μs
		When high-speed oscillation is active (V <sub>DD</sub> = 1.8 to 3.6V)	0.4	—	—	μs
SCLK output pulse width (master mode)	t <sub>SW</sub>	—	SCLK* <sup>1</sup> ×0.4	SCLK* <sup>1</sup> ×0.5	SCLK* <sup>1</sup> ×0.6	s
SOUT output delay time (slave mode)	t <sub>SD</sub>	—	—	—	180	ns
SOUT output delay time (master mode)	t <sub>SD</sub>	—	—	—	80	ns
SIN input setup time (slave mode)	t <sub>SS</sub>	—	80	—	—	ns
SIN input setup time (master mode)	t <sub>SS</sub>	—	180	—	—	ns
SIN input hold time	t <sub>SH</sub>	—	80	—	—	ns

\*1: Clock period selected with S0CK3-0 of the serial port 0 mode register (SIO0MOD1)

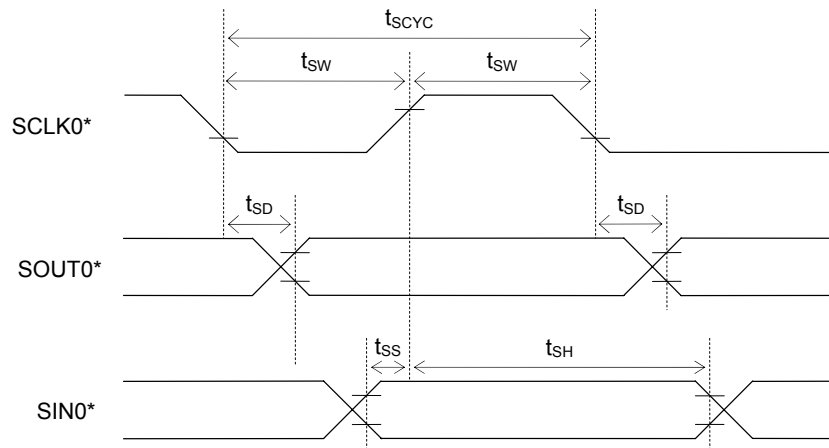

\*: Indicates the secondary function of the port.

**AC CHARACTERISTICS (I<sup>2</sup>C Bus Interface: Standard Mode 100kHz)**(V<sub>DD</sub> = 1.8 to 3.6V, V<sub>SS</sub> = 0V, Ta = -20 to +70°C, unless otherwise specified)

Parameter	Symbol	Condition	Rating			Unit
			Min.	Typ.	Max.	
SCL clock frequency	f <sub>SCL</sub>	—	0	—	100	kHz
SCL hold time (start/restart condition)	t <sub>HD:STA</sub>	—	4.0	—	—	μs
SCL "L" level time	t <sub>LOW</sub>	—	4.7	—	—	μs
SCL "H" level time	t <sub>HIGH</sub>	—	4.0	—	—	μs
SCL setup time (restart condition)	t <sub>SU:STA</sub>	—	4.7	—	—	μs
SDA hold time	t <sub>HD:DAT</sub>	—	0	—	3.45	μs
SDA setup time	t <sub>SU:DAT</sub>	—	0.25	—	—	μs
SDA setup time (stop condition)	t <sub>SU:STO</sub>	—	4.0	—	—	μs
Bus-free time	t <sub>BUF</sub>	—	4.7	—	—	μs

**AC CHARACTERISTICS (I<sup>2</sup>C Bus Interface: Fast Mode 400kHz)**(V<sub>DD</sub> = 1.8 to 3.6V, V<sub>SS</sub> = 0V, Ta = -20 to +70°C, unless otherwise specified)

Parameter	Symbol	Condition	Rating			Unit
			Min.	Typ.	Max.	
SCL clock frequency	f <sub>SCL</sub>	—	0	—	400	kHz
SCL hold time (start/restart condition)	t <sub>HD:STA</sub>	—	0.6	—	—	μs
SCL "L" level time	t <sub>LOW</sub>	—	1.3	—	—	μs
SCL "H" level time	t <sub>HIGH</sub>	—	0.6	—	—	μs
SCL setup time (restart condition)	t <sub>SU:STA</sub>	—	0.6	—	—	μs
SDA hold time	t <sub>HD:DAT</sub>	—	0	—	0.9	μs
SDA setup time	t <sub>SU:DAT</sub>	—	0.1	—	—	μs
SDA setup time (stop condition)	t <sub>SU:STO</sub>	—	0.6	—	—	μs
Bus-free time	t <sub>BUF</sub>	—	1.3	—	—	μs

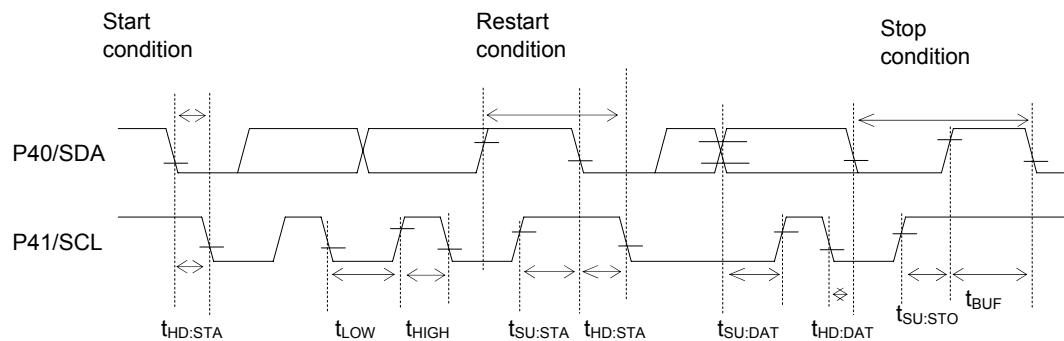

**AC CHARACTERISTICS (RC Oscillation A/D Converter)**(V<sub>DD</sub> = 1.3 to 3.6V, V<sub>SS</sub> = 0V, T<sub>a</sub> = -20 to +70°C, unless otherwise specified)

Parameter	Symbol	Condition	Rating			Unit
			Min.	Typ.	Max.	
Resistors for oscillation	RS0, RS1, RT0, RT0-1, RT1	CS0, CT0, CS1 ≥ 740pF	1	—	—	kΩ
Oscillation frequency VDD = 1.5V	f <sub>OSC1</sub>	Resistor for oscillation = 1kΩ	209.4	330.6	435.1	kHz
	f <sub>OSC2</sub>	Resistor for oscillation = 10kΩ	41.29	55.27	64.16	kHz
	f <sub>OSC3</sub>	Resistor for oscillation = 100kΩ	4.71	5.97	7.06	kHz
RS to RT oscillation frequency ratio *1 VDD = 1.5V	Kf1	RT0, RT0-1, RT1 = 1kHz	5.567	5.982	6.225	—
	Kf2	RT0, RT0-1, RT1 = 10 kHz	0.99	1	1.01	—
	Kf3	RT0, RT0-1, RT1 = 100 kHz	0.104	0.108	0.118	—
Oscillation frequency VDD = 3.0V	f <sub>OSC1</sub>	Resistor for oscillation = 1kΩ	407.3	486.7	594.6	kHz
	f <sub>OSC2</sub>	Resistor for oscillation = 10kΩ	49.76	59.28	72.76	kHz
	f <sub>OSC3</sub>	Resistor for oscillation = 100kΩ	5.04	5.993	7.04	kHz
RS to RT oscillation frequency ratio *1 VDD = 3.0V	Kf1	RT0, RT0-1, RT1 = 1kHz	8.006	8.210	8.416	—
	Kf2	RT0, RT0-1, RT1 = 10 kHz	0.99	1	1.01	—
	Kf3	RT0, RT0-1, RT1 = 100 kHz	0.100	0.108	0.115	—

\*1: Kfx is the ratio of the oscillation frequency by the sensor resistor to the oscillation frequency by the reference resistor on the same conditions.

$$Kfx = \frac{f_{oscx}(RT0-CS0 \text{ oscillation})}{f_{oscx}(RS0-CS0 \text{ oscillation})}, \quad \frac{f_{oscx}(RT0-1-CS0 \text{ oscillation})}{f_{oscx}(RS0-CS0 \text{ oscillation})}, \quad \frac{f_{oscx}(RT1-CS1 \text{ oscillation})}{f_{oscx}(RS1-CS1 \text{ oscillation})}$$

(x = 1, 2, 3)

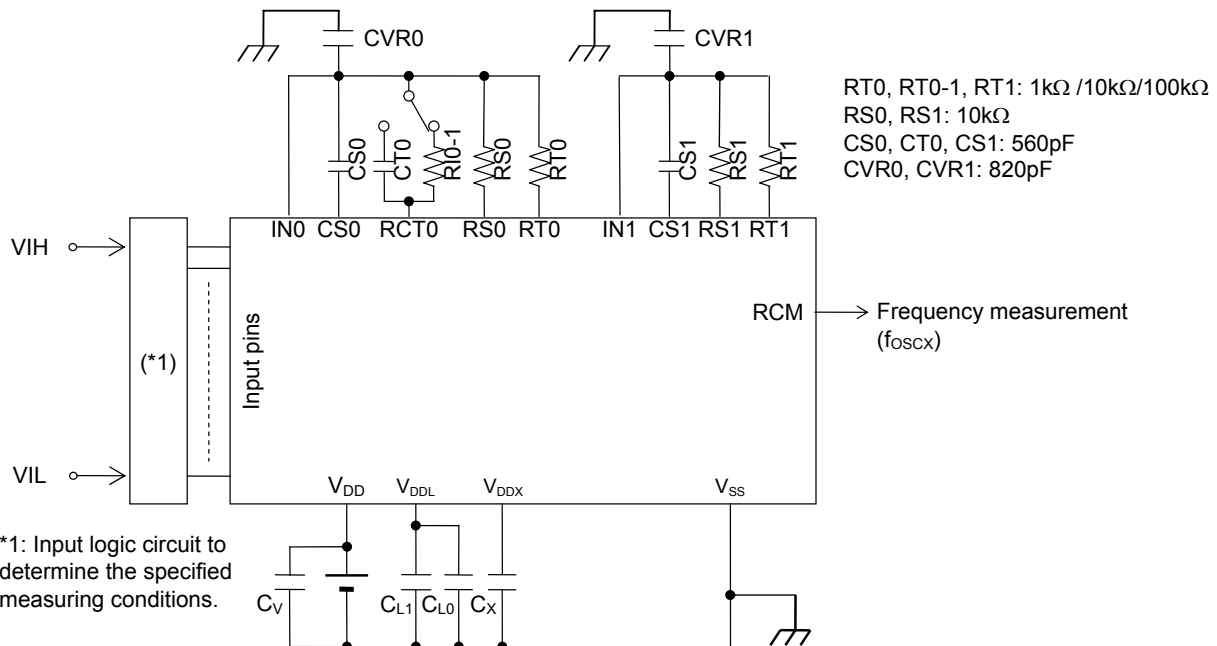
**Note:**

- Please have the shortest layout for the common node (wiring patterns which are connected to the external capacitors, resistors and IN0/IN1 pin), including CVR0/CVR1. Especially, do not have long wire between IN0/IN1 and RS0/RS1. The coupling capacitance on the wires may occur incorrect A/D conversion. Also, please do not have signals which may be a source of noise around the node.
- When RT0/RT1 (Thermistor and etc.) requires long wiring due to the restricted placement, please have VSS(GND) trace next to the signal.
- Please make wiring to components (capacitor, resistor and etc.) necessary for objective measurement. Wiring to reserved components may affect to the A/D conversion operation by noise the components itself may have.

Package Dimensions

(Unit: mm)

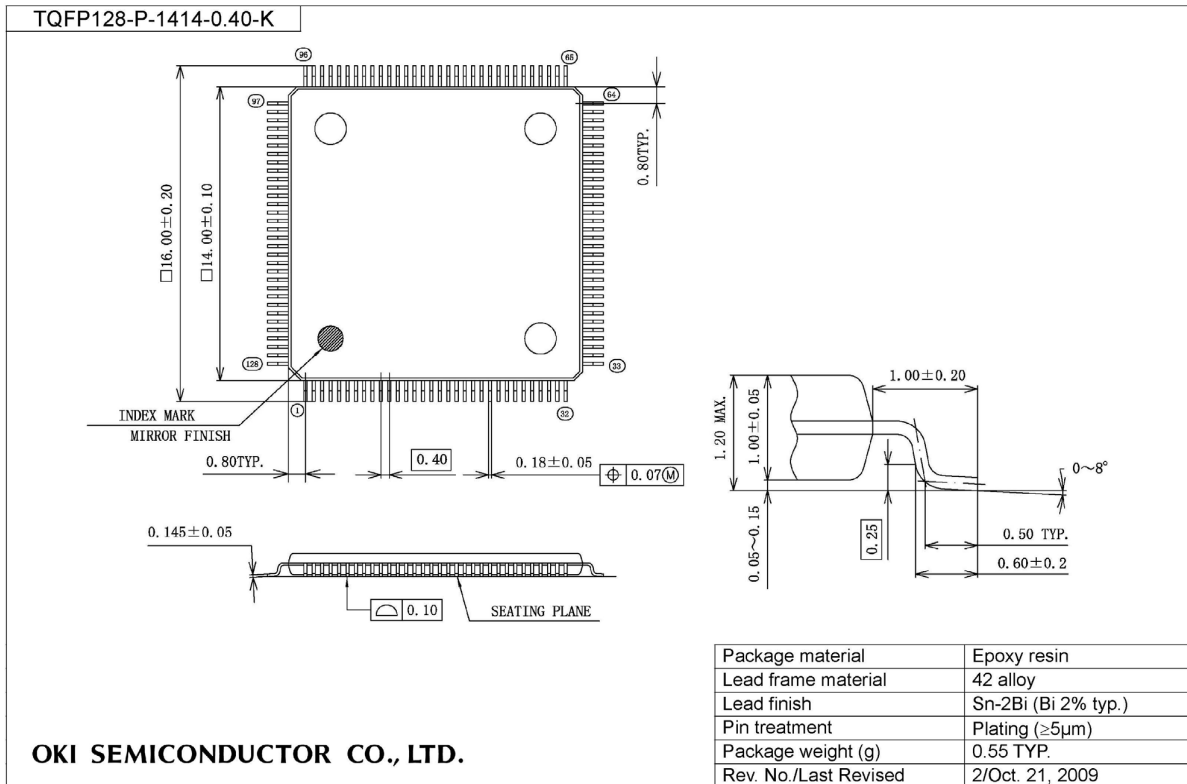

Notes for Mounting the Surface Mount Type Package

The surface mount type packages are very susceptible to heat in reflow mounting and humidity absorbed in storage. Therefore, before you perform reflow mounting, contact our responsible sales person for the product name, package name, pin number, package code and desired mounting conditions (reflow method, temperature and times).

**Revision History**

Document No.	Date	Page		Description
		Previous Edition	Current Edition	
FEDL610Q428-01	Feb.7.2011	-	-	Formally edition 1.0

NOTICE

1. The information contained herein can change without notice owing to product and/or technical improvements. Before using the product, please make sure that the information being referred to is up-to-date.
2. The outline of action and examples for application circuits described herein have been chosen as an explanation for the standard action and performance of the product. When planning to use the product, please ensure that the external conditions are reflected in the actual circuit, assembly, and program designs.
3. When designing your product, please use our product below the specified maximum ratings and within the specified operating ranges including, but not limited to, operating voltage, power dissipation, and operating temperature.
4. OKI SEMICONDUCTOR assumes no responsibility or liability whatsoever for any failure or unusual or unexpected operation resulting from misuse, neglect, improper installation, repair, alteration or accident, improper handling, or unusual physical or electrical stress including, but not limited to, exposure to parameters beyond the specified maximum ratings or operation outside the specified operating range.
5. Neither indemnity against nor license of a third party's industrial and intellectual property right, etc. is granted by us in connection with the use of the product and/or the information and drawings contained herein. No responsibility is assumed by us for any infringement of a third party's right which may result from the use thereof.
6. The products listed in this document are intended for use in general electronics equipment for commercial applications (e.g., office automation, communication equipment, measurement equipment, consumer electronics, etc.). These products are not, unless specifically authorized by OKI SEMICONDUCTOR authorized for use in any system or application that requires special or enhanced quality and reliability characteristics nor in any system or application where the failure of such system or application may result in the loss or damage of property, or death or injury to humans.  
Such applications include, but are not limited to, traffic and automotive equipment, safety devices, aerospace equipment, nuclear power control, medical equipment, and life-support systems.
7. Certain products in this document may need government approval before they can be exported to particular countries. The purchaser assumes the responsibility of determining the legality of export of these products and will take appropriate and necessary steps at their own expense for these.
8. No part of the contents contained herein may be reprinted or reproduced without our prior permission.

Copyright 2011 OKI SEMICONDUCTOR CO., LTD.