ML610Q421/ML610Q422

8-bit Microcontroller with a Built-in LCD driver

GENERAL DESCRIPTION

This LSI is a high-performance 8-bit CMOS microcontroller into which rich peripheral circuits, such as synchronous serial port, UART, I²C bus interface (master), melody driver, battery level detect circuit, RC oscillation type A/D converter, 12-bit successive approximation type A/D converter, and LCD driver, are incorporated around 8-bit CPU nX-U8/100.

The CPU nX-U8/100 is capable of efficient instruction execution in 1-instruction 1-clock mode by 3-stage pipe line architecture parallel processing. The Flash ROM that is installed as program memory achieves low-voltage low-power consumption operation (read operation) equivalent to mask ROM and is most suitable for battery-driven applications.

The on-chip debug function that is installed enables program debugging and programming.

FEATURES

- CPU
 - 8-bit RISC CPU (CPU name: nX-U8/100)
 - Instruction system: 16-bit instructions
 - Instruction set: Transfer, arithmetic operations, comparison, logic operations, multiplication/division, bit manipulations, bit logic operations, jump, conditional jump, call return stack manipulations, arithmetic shift, and so on
 - On-Chip debug function
 - Minimum instruction execution time
 - 30.5 μ s (@32.768 kHz system clock)
 - 0.24 μ s (@4.096 MHz system clock)
- Internal memory
 - Internal 32KByte Flash ROM (16K \times 16 bits) (including unusable 1KByte TEST area)
 - Internal 1KByte Data RAM (1024 \times 8 bits), 1KByte Display Allocation RAM (1024 x 8bit)
 - Internal 100Byte RAM for display
- Interrupt controller
 - 2 non-maskable interrupt sources (Internal source: 1, External source: 1)
 - 20 maskable interrupt sources (Internal sources: 16, External sources: 4)
- Time base counter
 - Low-speed time base counter \times 1 channel
 - Frequency compensation (Compensation range: Approx. -488 ppm to $+488$ ppm. Compensation accuracy: Approx. 0.48ppm)
 - High-speed time base counter \times 1 channel
- Watchdog timer
 - Non-maskable interrupt and reset
 - Free running
 - Overflow period: 4 types selectable (125ms, 500ms, 2s, and 8s)
- Timers
 - 8 bits \times 4 channels (Timer0-3: 16-bit \times 2 configuration available by using Timer0-1 or Timer2-3)
 - Clock frequency measurement mode (in one channel of 16-bit configuration using Timer2-3)

- 1 kHz timer
 - 10 Hz/1 Hz interrupt function
- Capture
 - Time base capture × 2 channels (4096 Hz to 32 Hz)
- PWM
 - Resolution 16 bits × 1 channel
- Synchronous serial port
 - Master/slave selectable
 - LSB first/MSB first selectable
 - 8-bit length/16-bit length selectable
- UART
 - TXD/RXD × 1 channel
 - Bit length, parity/no parity, odd parity/even parity, 1 stop bit/2 stop bits
 - Positive logic/negative logic selectable
 - Built-in baud rate generator
- I²C bus interface
 - Master function only
 - Fast mode (400 kbps@4MHz), standard mode (100 kbps@1MHz, 50kbps@500kHz)
- Melody driver
 - Scale: 29 types (Melody sound frequency: 508 Hz to 32.768 kHz)
 - Tone length: 63 types
 - Tempo: 15 types
 - Buzzer output mode (4 output modes, 8 frequencies, 16 duty levels)
- RC oscillation type A/D converter
 - 24-bit counter
 - Time division × 2 channels
- Successive approximation type A/D converter
 - 12-bit A/D converter
 - Input × 2 channels
- General-purpose ports
 - Non-maskable interrupt input port × 1 channel
 - Input-only port × 6 channels (including secondary functions)
 - Output-only port × 3 channels (including secondary functions)
 - Input/output port
 - ML610Q421: 22 channels (including secondary functions)
 - ML610Q422: 14 channels (including secondary functions)

- LCD driver
 - Dot matrix can be supported.
ML610Q421: 400 dots max. (50 seg × 8 com), 1/1 to 1/8 duty
ML610Q422: 800 dots max. (50 seg × 16 com), 1/1 to 1/16 duty
 - 1/3 or 1/4 bias (built-in bias generation circuit)
 - Frame frequency selectable (approx. 64 Hz, 73 Hz, 85 Hz, and 102 Hz)
 - Bias voltage multiplying clock selectable (8 types)
 - Contrast adjustment (1/3 bias: 32 steps, 1/4 bias: 20 steps)
 - LCD drive stop mode, LCD display mode, all LCDs on mode, and all LCDs off mode selectable
 - Programmable display allocation function (available only when 1/1~1/8 duty is selected)
- Reset
 - Reset through the RESET_N pin
 - Power-on reset generation when powered on
 - Reset when oscillation stop of the low-speed clock is detected
 - Reset by the watchdog timer (WDT) overflow
- Power supply voltage detect function
 - Judgment voltages: One of 16 levels
 - Judgment accuracy: ±2% (Typ.)
- Clock
 - Low-speed clock: (This LSI can not guarantee the operation without low-speed clock)
Crystal oscillation (32.768 kHz)
 - High-speed clock:
Built-in RC oscillation (500 kHz)
Built-in PLL oscillation (8.192 MHz ±2.5%), crystal/ceramic oscillation (4.096 MHz), external clock
 - Selection of high-speed clock mode by software:
Built-in RC oscillation, built-in PLL oscillation, crystal/ceramic oscillation, external clock
- Power management
 - HALT mode: Instruction execution by CPU is suspended (peripheral circuits are in operating states).
 - STOP mode: Stop of low-speed oscillation and high-speed oscillation (Operations of CPU and peripheral circuits are stopped.)
 - Clock gear: The frequency of high-speed system clock can be changed by software (1/1, 1/2, 1/4, or 1/8 of the oscillation clock)
 - Block Control Function: Power down (reset registers and stop clock supply) the circuits of unused peripherals.
- Shipment
 - Chip
ML610Q421(P)-xxxWA (Blank product: ML610Q421(P)-NNNWA)
ML610Q422(P)-xxxWA (Blank product: ML610Q422(P)-NNNWA)
 - 120-pin plastic TQFP
ML610Q421(P)-xxxTBZ03A (Blank product: ML610Q421(P)-NNNTBZ03A)
ML610Q422(P)-xxxTBZ03A (Blank product: ML610Q422(P)-NNNTBZ03A)
xxx: ROM code number
P: Wide range temperature version
- Guaranteed operating range
 - Operating temperature: -20°C to 70°C (P version: -40°C to +85°C)
 - Operating voltage: $V_{DD} = 1.1V$ to 3.6V, $AV_{DD} = 2.2V$ to 3.6V

BLOCK DIAGRAM
ML610Q421 Block Diagram

Figure 1 show the block diagram of the ML610Q421.
"*" indicates the secondary function of each port.

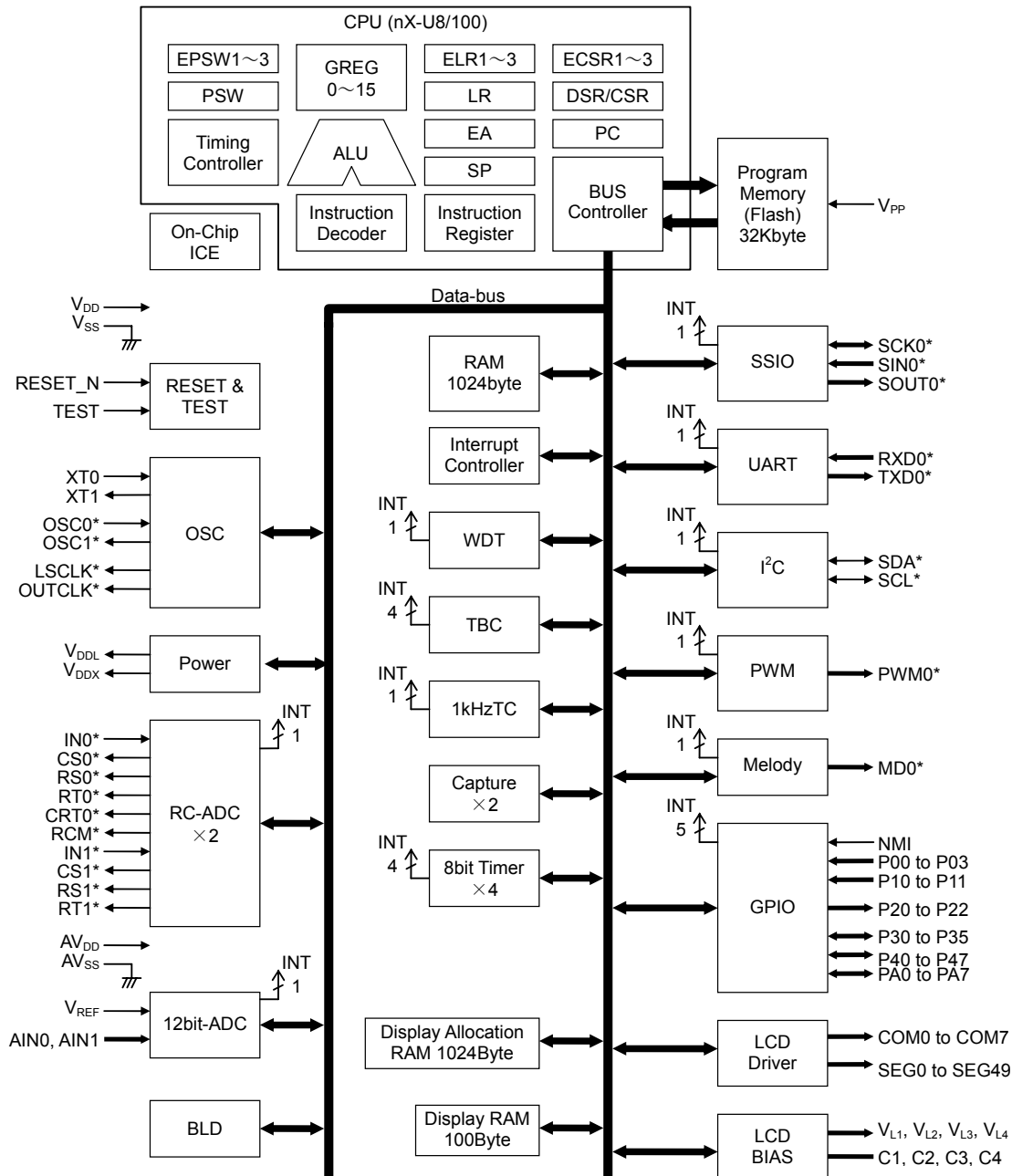

Figure 1 ML610Q421 Block Diagram

ML610Q422 Block Diagram

Figure 2 show the block diagram of the ML610Q422.
 "*" indicates the secondary function of each port.

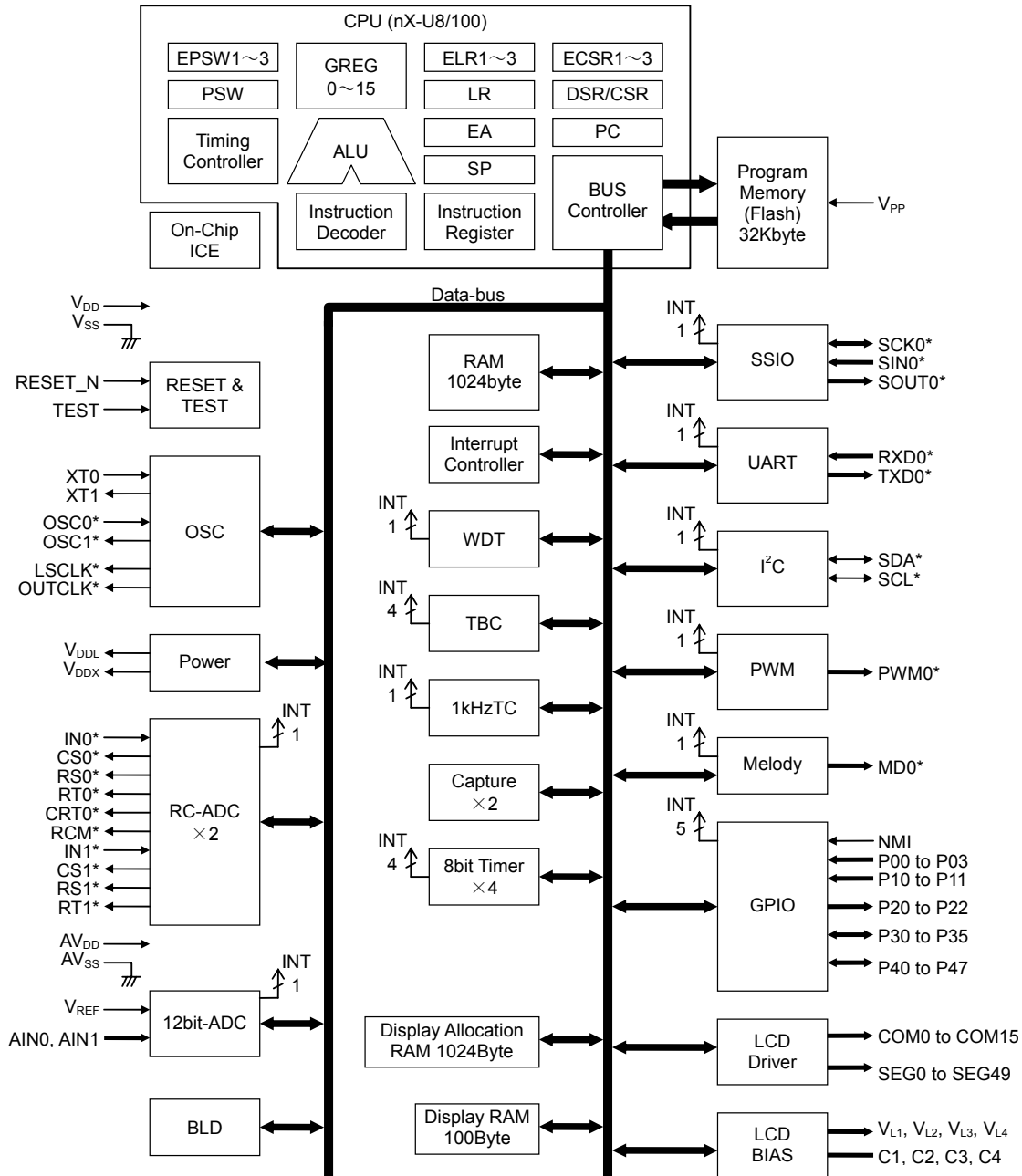
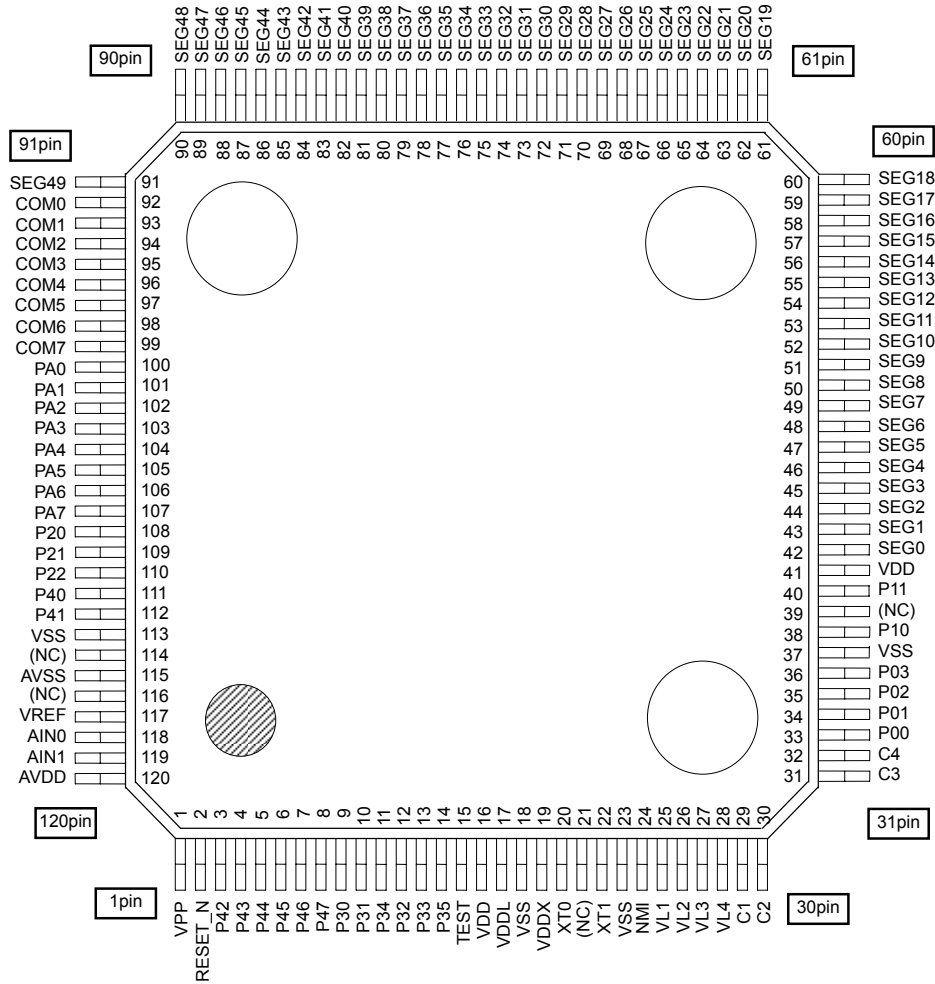

Figure 2 ML610Q422 Block Diagram

PIN CONFIGURATION
ML610Q421 TQFP120 Pin Layout



Note:
 The assignment of the pads P30 to P35 are not in order.

Figure 3 ML610Q421 TQFP120 Pin Configuration

ML610Q421 Chip Pin Layout & Dimension

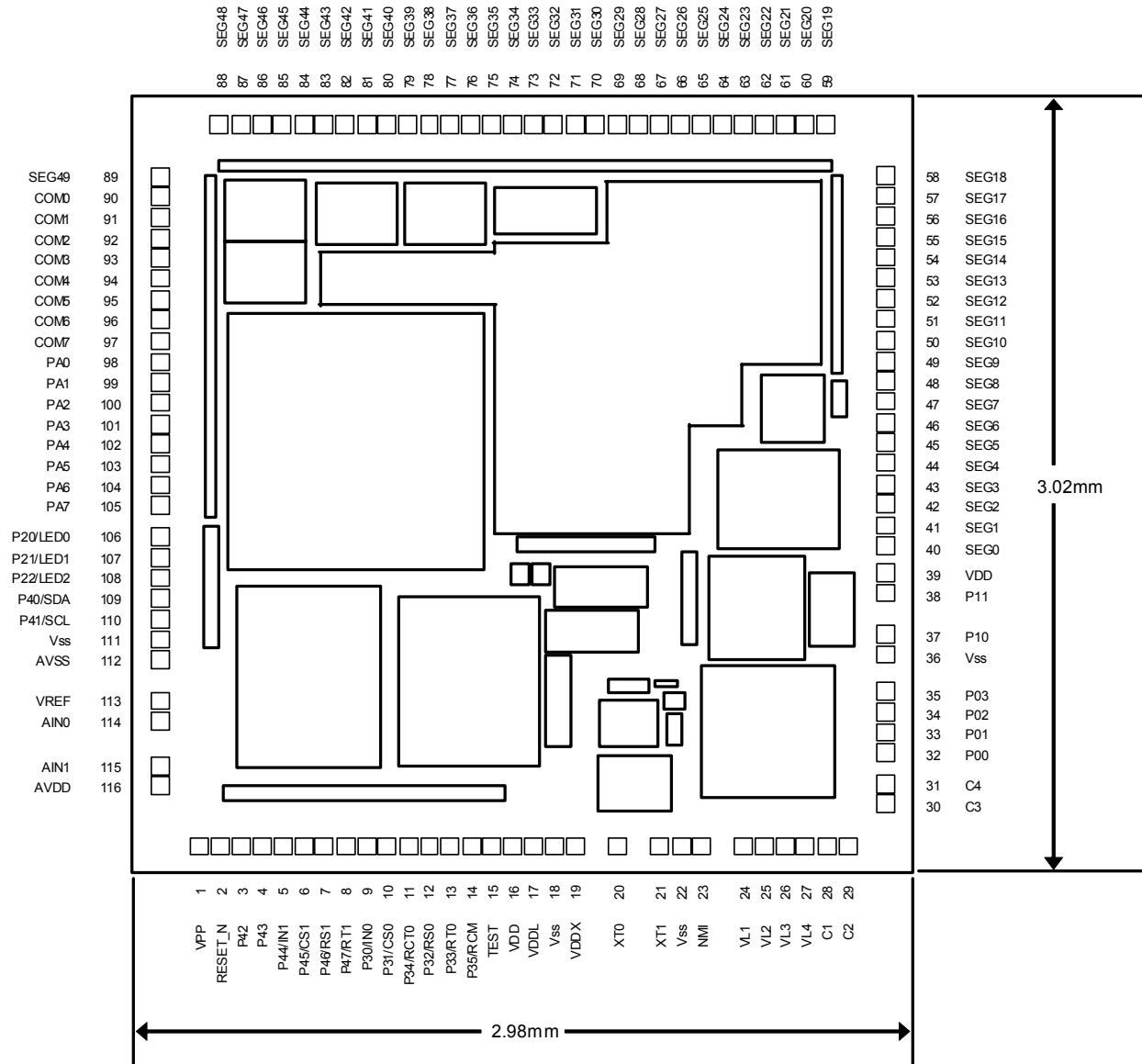

Note:
The assignment of the pads P30 to P35 are not in order.

Chip size:	2.98 mm × 3.02 mm
PAD count:	116 pins
Minimum PAD pitch:	80 μm
PAD aperture:	70 μm × 70 μm
Chip thickness:	350 μm
Voltage of the rear side of chip:	V _{SS} level

Figure 5 ML610Q421 Chip Layout & Dimension

ML610Q422 Chip Pin Layout & Dimension

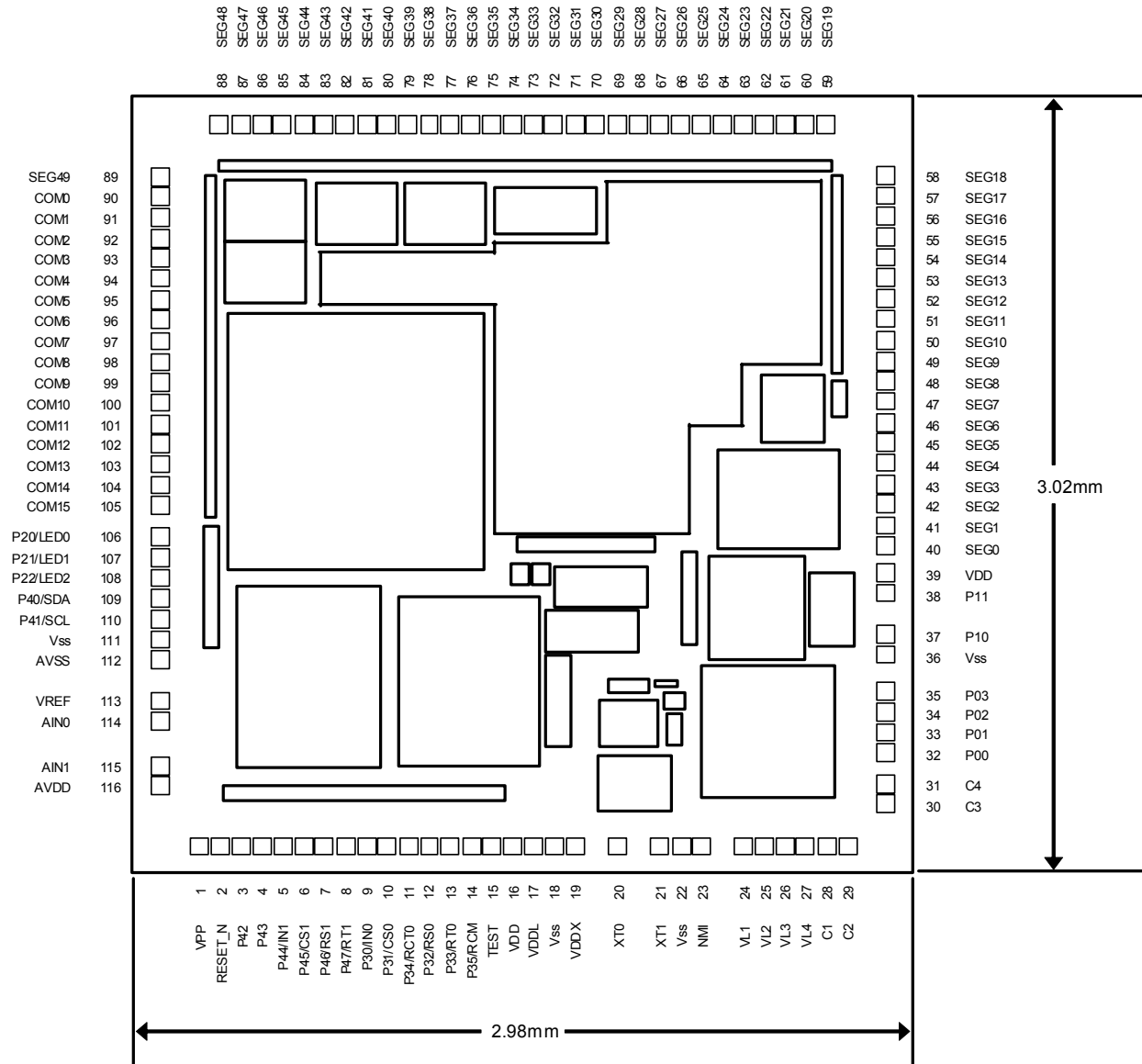

Note:
The assignment of the pads P30 to P35 are not in order.

Chip size:	2.98 mm × 3.02 mm
PAD count:	116 pins
Minimum PAD pitch:	80 μm
PAD aperture:	70 μm × 70 μm
Chip thickness:	350 μm
Voltage of the rear side of chip:	V _{SS} level

Figure 6 ML610Q422 Chip Layout & Dimension

ML610Q421 Pad Coordinates

Table 1 ML610Q421 Pad Coordinates

Chip Center: X=0,Y=0

PAD No.	Pad Name	X (μm)	Y (μm)	PAD No.	Pad Name	X (μm)	Y (μm)	PAD No.	Pad Name	X (μm)	Y (μm)
1	VPP	-1240	-1404	51	SEG11	1384	640	101	PA3	-1384	240
2	RESET_N	-1160	-1404	52	SEG12	1384	720	102	PA4	-1384	160
3	P42	-1080	-1404	53	SEG13	1384	800	103	PA5	-1384	80
4	P43	-1000	-1404	54	SEG14	1384	880	104	PA6	-1384	0
5	P44	-920	-1404	55	SEG15	1384	960	105	PA7	-1384	-80
6	P45	-840	-1404	56	SEG16	1384	1040	106	P20	-1384	-200
7	P46	-760	-1404	57	SEG17	1384	1120	107	P21	-1384	-280
8	P47	-680	-1404	58	SEG18	1384	1200	108	P22	-1384	-360
9	P30	-600	-1404	59	SEG19	1160	1404	109	P40	-1384	-440
10	P31	-520	-1404	60	SEG20	1080	1404	110	P41	-1384	-520
11	P34	-440	-1404	61	SEG21	1000	1404	111	Vss	-1384	-600
12	P32	-360	-1404	62	SEG22	920	1404	112	AVss	-1384	-680
13	P33	-280	-1404	63	SEG23	840	1404	113	VREF	-1384	-840
14	P35	-200	-1404	64	SEG24	760	1404	114	AIN0	-1384	-920
15	TEST	-120	-1404	65	SEG25	680	1404	115	AIN1	-1384	-1092
16	VDD	-40	-1404	66	SEG26	600	1404	116	AVDD	-1384	-1172
17	VDDL	40	-1404	67	SEG27	520	1404				
18	Vss	120	-1404	68	SEG28	440	1404				
19	VDDX	200	-1404	69	SEG29	360	1404				
20	XT0	360	-1404	70	SEG30	280	1404				
21	XT1	520	-1404	71	SEG31	200	1404				
22	Vss	600	-1404	72	SEG32	120	1404				
23	NMI	680	-1404	73	SEG33	40	1404				
24	VL1	840	-1404	74	SEG34	-40	1404				
25	VL2	920	-1404	75	SEG35	-120	1404				
26	VL3	1000	-1404	76	SEG36	-200	1404				
27	VL4	1080	-1404	77	SEG37	-280	1404				
28	C1	1160	-1404	78	SEG38	-360	1404				
29	C2	1240	-1404	79	SEG39	-440	1404				
30	C3	1384	-1240	80	SEG40	-520	1404				
31	C4	1384	-1160	81	SEG41	-600	1404				
32	P00	1384	-1040	82	SEG42	-680	1404				
33	P01	1384	-960	83	SEG43	-760	1404				
34	P02	1384	-880	84	SEG44	-840	1404				
35	P03	1384	-800	85	SEG45	-920	1404				
36	Vss	1384	-660	86	SEG46	-1000	1404				
37	P10	1384	-580	87	SEG47	-1080	1404				
38	P11	1384	-420	88	SEG48	-1160	1404				
39	VDD	1384	-340	89	SEG49	-1384	1200				
40	SEG0	1384	-240	90	COM0	-1384	1120				
41	SEG1	1384	-160	91	COM1	-1384	1040				
42	SEG2	1384	-80	92	COM2	-1384	960				
43	SEG3	1384	0	93	COM3	-1384	880				
44	SEG4	1384	80	94	COM4	-1384	800				
45	SEG5	1384	160	95	COM5	-1384	720				
46	SEG6	1384	240	96	COM6	-1384	640				
47	SEG7	1384	320	97	COM7	-1384	560				
48	SEG8	1384	400	98	PA0	-1384	480				
49	SEG9	1384	480	99	PA1	-1384	400				
50	SEG10	1384	560	100	PA2	-1384	320				

ML610Q422 Pad Coordinates

Table 2 ML610Q422 Pad Coordinates

Chip Center: X=0,Y=0

PAD No.	Pad Name	X (μm)	Y (μm)	PAD No.	Pad Name	X (μm)	Y (μm)	PAD No.	Pad Name	X (μm)	Y (μm)
1	VPP	-1240	-1404	51	SEG11	1384	640	101	COM11	-1384	240
2	RESET_N	-1160	-1404	52	SEG12	1384	720	102	COM12	-1384	160
3	P42	-1080	-1404	53	SEG13	1384	800	103	COM13	-1384	80
4	P43	-1000	-1404	54	SEG14	1384	880	104	COM14	-1384	0
5	P44	-920	-1404	55	SEG15	1384	960	105	COM15	-1384	-80
6	P45	-840	-1404	56	SEG16	1384	1040	106	P20	-1384	-200
7	P46	-760	-1404	57	SEG17	1384	1120	107	P21	-1384	-280
8	P47	-680	-1404	58	SEG18	1384	1200	108	P22	-1384	-360
9	P30	-600	-1404	59	SEG19	1160	1404	109	P40	-1384	-440
10	P31	-520	-1404	60	SEG20	1080	1404	110	P41	-1384	-520
11	P34	-440	-1404	61	SEG21	1000	1404	111	Vss	-1384	-600
12	P32	-360	-1404	62	SEG22	920	1404	112	AVss	-1384	-680
13	P33	-280	-1404	63	SEG23	840	1404	113	VREF	-1384	-840
14	P35	-200	-1404	64	SEG24	760	1404	114	AIN0	-1384	-920
15	TEST	-120	-1404	65	SEG25	680	1404	115	AIN1	-1384	-1092
16	VDD	-40	-1404	66	SEG26	600	1404	116	AVDD	-1384	-1172
17	VDDL	40	-1404	67	SEG27	520	1404				
18	Vss	120	-1404	68	SEG28	440	1404				
19	VDDX	200	-1404	69	SEG29	360	1404				
20	XT0	360	-1404	70	SEG30	280	1404				
21	XT1	520	-1404	71	SEG31	200	1404				
22	Vss	600	-1404	72	SEG32	120	1404				
23	NMI	680	-1404	73	SEG33	40	1404				
24	VL1	840	-1404	74	SEG34	-40	1404				
25	VL2	920	-1404	75	SEG35	-120	1404				
26	VL3	1000	-1404	76	SEG36	-200	1404				
27	VL4	1080	-1404	77	SEG37	-280	1404				
28	C1	1160	-1404	78	SEG38	-360	1404				
29	C2	1240	-1404	79	SEG39	-440	1404				
30	C3	1384	-1240	80	SEG40	-520	1404				
31	C4	1384	-1160	81	SEG41	-600	1404				
32	P00	1384	-1040	82	SEG42	-680	1404				
33	P01	1384	-960	83	SEG43	-760	1404				
34	P02	1384	-880	84	SEG44	-840	1404				
35	P03	1384	-800	85	SEG45	-920	1404				
36	Vss	1384	-660	86	SEG46	-1000	1404				
37	P10	1384	-580	87	SEG47	-1080	1404				
38	P11	1384	-420	88	SEG48	-1160	1404				
39	VDD	1384	-340	89	SEG49	-1384	1200				
40	SEG0	1384	-240	90	COM0	-1384	1120				
41	SEG1	1384	-160	91	COM1	-1384	1040				
42	SEG2	1384	-80	92	COM2	-1384	960				
43	SEG3	1384	0	93	COM3	-1384	880				
44	SEG4	1384	80	94	COM4	-1384	800				
45	SEG5	1384	160	95	COM5	-1384	720				
46	SEG6	1384	240	96	COM6	-1384	640				
47	SEG7	1384	320	97	COM7	-1384	560				
48	SEG8	1384	400	98	COM8	-1384	480				
49	SEG9	1384	480	99	COM9	-1384	400				
50	SEG10	1384	560	100	COM10	-1384	320				

PIN LIST

PAD No.		Primary function			Secondary function			Tertiary function		
Q422	Q421	Pin name	I/O	Function	Pin name	I/O	Function	Pin name	I/O	Function
18,22, 36,111	18,22, 37,111	V _{SS}	—	Negative power supply pin	—	—	—	—	—	—
16,39	16,39	V _{DD}	—	Positive power supply pin	—	—	—	—	—	—
17	17	V _{DDL}	—	Power supply pin for internal logic (internally generated)	—	—	—	—	—	—
19	19	V _{DDX}	—	Power supply pin for low-speed oscillation (internally generated)	—	—	—	—	—	—
1	1	V _{PP}	—	Power supply pin for Flash ROM	—	—	—	—	—	—
112	112	AV _{SS}	—	Negative power supply pin for successive approximation type ADC	—	—	—	—	—	—
116	116	AV _{DD}	—	Positive power supply pin for successive approximation type ADC	—	—	—	—	—	—
24	24	V _{L1}	—	Power supply pin for LCD bias (internally generated)	—	—	—	—	—	—
25	25	V _{L2}	—	Power supply pin for LCD bias (internally generated)	—	—	—	—	—	—
26	26	V _{L3}	—	Power supply pin for LCD bias (internally generated)	—	—	—	—	—	—
27	27	V _{L4}	—	Power supply pin for LCD bias (internally generated)	—	—	—	—	—	—
28	28	C1	—	Capacitor connection pin for LCD bias generation	—	—	—	—	—	—
29	29	C2	—	Capacitor connection pin for LCD bias generation	—	—	—	—	—	—
30	30	C3	—	Capacitor connection pin for LCD bias generation	—	—	—	—	—	—
31	31	C4	—	Capacitor connection pin for LCD bias generation	—	—	—	—	—	—
15	15	TEST	I/O	Input/output pin for testing	—	—	—	—	—	—
2	2	RESET _N	I	Reset input pin	—	—	—	—	—	—
20	20	XT0	I	Low-speed clock oscillation pin	—	—	—	—	—	—
21	21	XT1	O	Low-speed clock oscillation pin	—	—	—	—	—	—
113	113	V _{REF}	—	Reference power supply pin for successive approximation type ADC	—	—	—	—	—	—

PAD No.		Primary function			Secondary function			Tertiary function		
Q422	Q421	Pin name	I/O	Function	Pin name	I/O	Function	Pin name	I/O	Function
114	114	AIN0	I	Successive approximation type ADC input	—	—	—	—	—	—
115	115	AIN1	I	Successive approximation type ADC input	—	—	—	—	—	—
23	23	NMI	I	Non-maskable interrupt pin	—	—	—	—	—	—
32	32	P00/EXI0/CAP0	I	Input port, External interrupt 0, Capture 0 input	—	—	—	—	—	—
33	33	P01/EXI1/CAP1	I	Input port, External interrupt 1, Capture 1 input	—	—	—	—	—	—
34	34	P02/EXI2/RXD0	I	Input port, External interrupt 2, UART0 receive	—	—	—	—	—	—
35	35	P03/EXI3	I	Input port, External interrupt 3	—	—	—	—	—	—
37	37	P10	I	Input port	OSC0	I	High-speed oscillation	—	—	—
38	38	P11	I	Input port	OSC1	O	High-speed oscillation	—	—	—
106	106	P20/LE D0	O	Output port	LSCLK	O	Low-speed clock output	—	—	—
107	107	P21/LED1	O	Output port	OUTCLK	O	High-speed clock output	—	—	—
108	108	P22/LE D2	O	Output port	MD0	O	Melody output	—	—	—
9	9	P30	I/O	Input/output port	IN0	I	RC type ADC0 oscillation input pin	—	—	—
10	10	P31	I/O	Input/output port	CS0	O	RC type ADC0 reference capacitor connection pin	—	—	—
11	11	P34	I/O	Input/output port	RCT0	O	RC type ADC0 resistor/capacitor sensor connection pin	PWM0	O	PWM output
12	12	P32	I/O	Input/output port	RS0	O	RC type ADC0 reference resistor connection pin	—	—	—
13	13	P33	I/O	Input/output port	RT0	O	RC type ADC0 resistor sensor connection pin	—	—	—
14	14	P35	I/O	Input/output port	RCM	O	RC type ADC oscillation monitor	—	—	—
109	109	P40	I/O	Input/output port	SDA	I/O	I ² C data input/output	SIN0	I	SSIO data input
110	110	P41	I/O	Input/output port	SCL	I/O	I ² C clock input/output	SCK0	I/O	SSIO synchronous clock
3	3	P42	I/O	Input/output port	RXD0	I	UART data input	SOUT0	I	SSIO data output
4	4	P43	I/O	Input/output port	TXD0	O	UART data output	PWM0	O	PWM output
5	5	P44/T02 P0CK	I/O	Input/output port, Timer 0/Timer 2/PWM0 external clock input	IN1	I	RC type ADC1 oscillation input pin	SIN0	I	SSIO0 data input
6	6	P45/T13 P1CK	I/O	Input/output port, Timer 1/Timer 3 external clock input	CS1	O	RC type ADC1 reference capacitor connection pin	SCK0	I/O	SSIO0 synchronous clock
7	7	P46	I/O	Input/output port	RS1	O	RC type ADC1 reference resistor connection pin	SOUT0	O	SSIO0 data output
8	8	P47	I/O	Input/output port	RT1	O	RC type ADC1 resistor sensor connection pin	—	—	—
—	98	PA0	I/O	Input/output port	—	—	—	—	—	—
—	99	PA1	I/O	Input/output port	—	—	—	—	—	—
—	100	PA2	I/O	Input/output port	—	—	—	—	—	—
—	101	PA3	I/O	Input/output port	—	—	—	—	—	—
—	102	PA4	I/O	Input/output port	—	—	—	—	—	—

PAD No.		Primary function			Secondary function			Tertiary function		
Q422	Q421	Pin name	I/O	Function	Pin name	I/O	Function	Pin name	I/O	Function
—	103	PA5	I/O	Input/output port	—	—	—	—	—	—
—	104	PA6	I/O	Input/output port	—	—	—	—	—	—
—	105	PA7	I/O	Input/output port	—	—	—	—	—	—
90	90	COM0	O	LCD common pin	—	—	—	—	—	—
91	91	COM1	O	LCD common pin	—	—	—	—	—	—
92	92	COM2	O	LCD common pin	—	—	—	—	—	—
93	93	COM3	O	LCD common pin	—	—	—	—	—	—
94	94	COM4	O	LCD common pin	—	—	—	—	—	—
95	95	COM5	O	LCD common pin	—	—	—	—	—	—
96	96	COM6	O	LCD common pin	—	—	—	—	—	—
97	97	COM7	O	LCD common pin	—	—	—	—	—	—
98	—	COM8	O	LCD common pin	—	—	—	—	—	—
99	—	COM9	O	LCD common pin	—	—	—	—	—	—
100	—	COM10	O	LCD common pin	—	—	—	—	—	—
101	—	COM11	O	LCD common pin	—	—	—	—	—	—
102	—	COM12	O	LCD common pin	—	—	—	—	—	—
103	—	COM13	O	LCD common pin	—	—	—	—	—	—
104	—	COM14	O	LCD common pin	—	—	—	—	—	—
105	—	COM15	O	LCD common pin	—	—	—	—	—	—
40	40	SEG0	O	LCD segment pin	—	—	—	—	—	—
41	41	SEG1	O	LCD segment pin	—	—	—	—	—	—
42	42	SEG2	O	LCD segment pin	—	—	—	—	—	—
43	43	SEG3	O	LCD segment pin	—	—	—	—	—	—
44	44	SEG4	O	LCD segment pin	—	—	—	—	—	—
45	45	SEG5	O	LCD segment pin	—	—	—	—	—	—
46	46	SEG6	O	LCD segment pin	—	—	—	—	—	—
47	47	SEG7	O	LCD segment pin	—	—	—	—	—	—
48	48	SEG8	O	LCD segment pin	—	—	—	—	—	—
49	49	SEG9	O	LCD segment pin	—	—	—	—	—	—
50	50	SEG10	O	LCD segment pin	—	—	—	—	—	—
51	51	SEG11	O	LCD segment pin	—	—	—	—	—	—
52	52	SEG12	O	LCD segment pin	—	—	—	—	—	—
53	53	SEG13	O	LCD segment pin	—	—	—	—	—	—
54	54	SEG14	O	LCD segment pin	—	—	—	—	—	—
55	55	SEG15	O	LCD segment pin	—	—	—	—	—	—
56	56	SEG16	O	LCD segment pin	—	—	—	—	—	—
57	57	SEG17	O	LCD segment pin	—	—	—	—	—	—
58	58	SEG18	O	LCD segment pin	—	—	—	—	—	—
59	59	SEG19	O	LCD segment pin	—	—	—	—	—	—
60	60	SEG20	O	LCD segment pin	—	—	—	—	—	—
61	61	SEG21	O	LCD segment pin	—	—	—	—	—	—
62	62	SEG22	O	LCD segment pin	—	—	—	—	—	—
63	63	SEG23	O	LCD segment pin	—	—	—	—	—	—
64	64	SEG24	O	LCD segment pin	—	—	—	—	—	—
65	65	SEG25	O	LCD segment pin	—	—	—	—	—	—
66	66	SEG26	O	LCD segment pin	—	—	—	—	—	—
67	67	SEG27	O	LCD segment pin	—	—	—	—	—	—
68	68	SEG28	O	LCD segment pin	—	—	—	—	—	—
69	69	SEG29	O	LCD segment pin	—	—	—	—	—	—
70	70	SEG30	O	LCD segment pin	—	—	—	—	—	—
71	71	SEG31	O	LCD segment pin	—	—	—	—	—	—
72	72	SEG32	O	LCD segment pin	—	—	—	—	—	—
73	73	SEG33	O	LCD segment pin	—	—	—	—	—	—

PAD No.		Primary function			Secondary function			Tertiary function		
Q422	Q421	Pin name	I/O	Function	Pin name	I/O	Function	Pin name	I/O	Function
74	74	SEG34	O	LCD segment pin	—	—	—	—	—	—
75	75	SEG35	O	LCD segment pin	—	—	—	—	—	—
76	76	SEG36	O	LCD segment pin	—	—	—	—	—	—
77	77	SEG37	O	LCD segment pin	—	—	—	—	—	—
78	78	SEG38	O	LCD segment pin	—	—	—	—	—	—
79	79	SEG39	O	LCD segment pin	—	—	—	—	—	—
80	80	SEG40	O	LCD segment pin	—	—	—	—	—	—
81	81	SEG41	O	LCD segment pin	—	—	—	—	—	—
82	82	SEG42	O	LCD segment pin	—	—	—	—	—	—
83	83	SEG43	O	LCD segment pin	—	—	—	—	—	—
84	84	SEG44	O	LCD segment pin	—	—	—	—	—	—
85	85	SEG45	O	LCD segment pin	—	—	—	—	—	—
86	86	SEG46	O	LCD segment pin	—	—	—	—	—	—
87	87	SEG47	O	LCD segment pin	—	—	—	—	—	—
88	88	SEG48	O	LCD segment pin	—	—	—	—	—	—
89	89	SEG49	O	LCD segment pin	—	—	—	—	—	—

PIN DESCRIPTION

Pin name	I/O	Description	Primary/ Secondary/ Tertiary	Logic
System				
RESET_N	I	Reset input pin. When this pin is set to a "L" level, system reset mode is set and the internal section is initialized. When this pin is set to a "H" level subsequently, program execution starts. A pull-up resistor is internally connected.	—	Negative
XT0	I	Crystal connection pin for low-speed clock.	—	—
XT1	O	A 32.768 kHz crystal oscillator (see measuring circuit 1) is connected to this pin. Capacitors CDL and CGL are connected across this pin and V _{SS} as required.	—	—
OSC0	I	Crystal/ceramic connection pin for high-speed clock.	Secondary	—
OSC1	O	A crystal or ceramic is connected to this pin (4.1 MHz max.). Capacitors CDH and CGH (see measuring circuit 1) are connected across this pin and V _{SS} . This pin is used as the secondary function of the P10 pin(OSC0) and P11 pin(OSC1).	Secondary	—
LSCLK	O	Low-speed clock output pin. This pin is used as the secondary function of the P20 pin.	Secondary	—
OUTCLK	O	High-speed clock output pin. This pin is used as the secondary function of the P21 pin.	Secondary	—
General-purpose input port				
P00-P03	I	General-purpose input port. Since these pins have secondary functions, the pins cannot be used as a port when the secondary functions are used.	Primary	Positive
P10-P11	I	General-purpose input port. Since these pins have secondary functions, the pins cannot be used as a port when the secondary functions are used.	Primary	Positive
General-purpose output port				
P20-P22	O	General-purpose output port. Since these pins have secondary functions, the pins cannot be used as a port when the secondary functions are used.	Primary	Positive
General-purpose input/output port				
P30-P35	I/O	General-purpose input/output port. Since these pins have secondary functions, the pins cannot be used as a port when the secondary functions are used.	Primary	Positive
P40-P47	I/O	General-purpose input/output port. Since these pins have secondary functions, the pins cannot be used as a port when the secondary functions are used.	Primary	Positive
PA0-PA7	I/O	General-purpose input/output port. These pins are for the ML610Q421, but are not provided in the ML610Q422.	Primary	Positive

Pin name	I/O	Description	Primary/ Secondary/ Tertiary	Logic
UART				
TXD0	O	UART data output pin. This pin is used as the secondary function of the P43 pin.	Secondary	Positive
RXD0	I	UART data input pin. This pin is used as the secondary function of the P42 or the primary function of the P02 pin.	Primary/Secondary	Positive
I²C bus interface				
SDA	I/O	I ² C data input/output pin. This pin is used as the secondary function of the P40 pin. This pin has an NMOS open drain output. When using this pin as a function of the I ² C, externally connect a pull-up resistor.	Secondary	Positive
SCL	O	I ² C clock output pin. This pin is used as the secondary function of the P41 pin. This pin has an NMOS open drain output. When using this pin as a function of the I ² C, externally connect a pull-up resistor.	Secondary	Positive
Synchronous serial (SSIO)				
SCK0	I/O	Synchronous serial clock input/output pin. This pin is used as the tertiary function of the P41 or P45 pin.	Tertiary	—
SIN0	I	Synchronous serial data input pin. This pin is used as the tertiary function of the P40 or P44 pin.	Tertiary	Positive
SOUT0	O	Synchronous serial data output pin. This pin is used as the tertiary function of the P42 or P46 pin.	Tertiary	Positive
PWM				
PWM0	O	PWM0 output pin. This pin is used as the tertiary function of the P43 or P34 pin.	Tertiary	Positive
T02P0CK	O	PWM0 external clock input pin. This pin is used as the primary function of the P44 pin.	Primary	—
External interrupt				
NMI	I	External non-maskable interrupt input pin. An interrupt is generated on both edges.	Primary	Positive/negative
EXI0-3	I	External maskable interrupt input pins. Interrupt enable and edge selection can be performed for each bit by software. These pins are used as the primary functions of the P00-P03 pins.	Primary	Positive/negative
Capture				
CAP0	I	Capture trigger input pins. The value of the time base counter is captured in the register synchronously with the interrupt edge selected by software.	Primary	Positive/negative
CAP1	I	These pins are used as the primary functions of the P00 pin(CAP0) and P01 pin(CAP1).	Primary	Positive/negative
Timer				
T02P0CK	I	External clock input pin used for both Timer 0 and Timer 2. The clocks for these timers are selected by software. This pin is used as the primary function of the P44 pin.	Primary	—
T13P1CK	I	External clock input pin used for both Timer 1 and Timer 3. The clocks for these timers are selected by software. This pin is used as the primary function of the P45 pin.	Primary	—
Melody				
MD0	O	Melody/buzzer signal output pin. This pin is used as the secondary function of the P22 pin.	Secondary	Positive/negative
LED drive				
LED0-2	O	Nch open drain output pins to drive LED.	Primary	Positive/negative

Pin name	I/O	Description	Primary/ Secondary/ Tertiary	Logic
RC oscillation type A/D converter				
IN0	I	Channel 0 oscillation input pin. This pin is used as the secondary function of the P30 pin.	Secondary	—
CS0	O	Channel 0 reference capacitor connection pin. This pin is used as the secondary function of the P31 pin.	Secondary	—
RS0	O	This pin is used as the secondary function of the P32 pin which is the reference resistor connection pin of Channel 0.	Secondary	—
RT0	O	Resistor sensor connection pin of Channel 0 for measurement. This pin is used as the secondary function of the P34 pin.	Secondary	—
CRT0	O	Resistor/capacitor sensor connection pin of Channel 0 for measurement. This pin is used as the secondary function of the P33 pin.	Secondary	—
RCM	O	RC oscillation monitor pin. This pin is used as the secondary function of the P35 pin.	Secondary	—
IN1	I	Oscillation input pin of Channel 1. This pin is used as the secondary function of the P44 pin.	Secondary	—
CS1	O	Reference capacitor connection pin of Channel 1. This pin is used as the secondary function of the P45 pin.	Secondary	—
RS1	O	Reference resistor connection pin of Channel 1. This pin is used as the secondary function of the P46 pin.	Secondary	—
RT1	O	Resistor sensor connection pin for measurement of Channel 1. This pin is used as the secondary function of the P47 pin.	Secondary	—
Successive approximation type A/D converter				
AV _{SS}	—	Negative power supply pin for successive approximation type A/D converter.	—	—
AV _{DD}	—	Positive power supply pin for successive approximation type A/D converter.	—	—
V _{REF}	—	Reference power supply pin for successive approximation type A/D converter.	—	—
AIN0	I	Channel 0 analog input for successive approximation type A/D converter.	—	—
AIN1	I	Channel 1 analog input for successive approximation type A/D converter.	—	—
LCD drive signal				
COM0-7	O	Common output pins.	—	—
COM8-15	O	Common output pins. These pins are for the ML610Q422, but are not provided in the ML610Q421.	—	—
SEG0-49	O	Segment output pin.	—	—
LCD driver power supply				
V _{L1}	—	Power supply pins for LCD bias (internally generated). Capacitors Ca, Cb, Cc, and Cd (see measuring circuit 1) are connected between V _{SS} and V _{L1} , V _{L2} , V _{L3} , and V _{L4} , respectively.	—	—
V _{L2}	—		—	—
V _{L3}	—		—	—
V _{L4}	—		—	—
C1	—	Power supply pins for LCD bias (internally generated). Capacitors C12 and C34 (see measuring circuit 1) are connected between C1 and C2 and between C3 and C4, respectively.	—	—
C2	—		—	—
C3	—		—	—
C4	—		—	—
For testing				
TEST	I/O	Input/output pin for testing. A pull-down resistor is internally connected.	—	—
Power supply				
V _{SS}	—	Negative power supply pin.	—	—
V _{DD}	—	Positive power supply pin.	—	—
V _{DDL}	—	Positive power supply pin (internally generated) for internal logic. Capacitors CL0 and CL1 (see measuring circuit 1) are connected between this pin and V _{SS} .	—	—
V _{DDX}	—	Plus-side power supply pin (internally generated) for low-speed oscillation. Capacitor Cx (see measuring circuit 1) is connected between this pin and V _{SS} .	—	—
V _{PP}	—	Power supply pin for programming Flash ROM. A pull-up resistor is internally connected.	—	—

TERMINATION OF UNUSED PINS

Table 3 shows methods of terminating the unused pins.

Table 3 Termination of Unused Pins

Pin	Recommended pin termination
V _{PP}	Open
AV _{DD}	V _{SS}
AV _{SS}	V _{SS}
V _{REF}	V _{SS}
AIN0, AIN1	Open
V _{L1} , V _{L2} , V _{L3} , V _{L4}	Open
C1, C2, C3, C4	Open
RESET_N	Open
TEST	Open
NMI	Open
P00 to P03	V _{DD} or V _{SS}
P10 to P11	V _{DD}
P20 to P22	Open
P30 to P35	Open
P40 to P47	Open
PA0 to PA7	Open
COM0 to 15	Open
SEG0 to 49	Open

Note:

It is recommended to set the unused input ports and input/output ports to the inputs with pull-down resistors/pull-up resistors or the output mode since the supply current may become excessively large if the pins are left open in the high impedance input setting.

ELECTRICAL CHARACTERISTICS**ABSOLUTE MAXIMUM RATINGS**(V_{SS} = AV_{SS} = 0V)

Parameter	Symbol	Condition	Rating	Unit
Power supply voltage 1	V _{DD}	Ta = 25°C	-0.3 to +4.6	V
Power supply voltage 2	AV _{DD}	Ta = 25°C	-0.3 to +4.6	V
Power supply voltage 3	V _{PP}	Ta = 25°C	-0.3 to +9.5	V
Power supply voltage 4	V _{DDL}	Ta = 25°C	-0.3 to +3.6	V
Power supply voltage 5	V _{DDX}	Ta = 25°C	-0.3 to +3.6	V
Power supply voltage 6	V _{L1}	Ta = 25°C	-0.3 to +1.75	V
Power supply voltage 7	V _{L2}	Ta = 25°C	-0.3 to +3.5	V
Power supply voltage 8	V _{L3}	Ta = 25°C	-0.3 to +5.25	V
Power supply voltage 9	V _{L4}	Ta = 25°C	-0.3 to +7.0	V
Input voltage	V _{IN}	Ta = 25°C	-0.3 to V _{DD} +0.3	V
Output voltage	V _{OUT}	Ta = 25°C	-0.3 to V _{DD} +0.3	V
Output current 1	I _{OUT1}	Port3-A, Ta = 25°C	-12 to +11	mA
Output current 2	I _{OUT2}	Port2, Ta = 25°C	-12 to +20	mA
Power dissipation	PD	Ta = 25°C	1.25	W
Storage temperature	T _{STG}	—	-55 to +150	°C

RECOMMENDED OPERATING CONDITIONS(V_{SS} = AV_{SS} = 0V)

Parameter	Symbol	Condition	Range	Unit
Operating temperature	T _{OP}	ML610Q421, ML610Q422	-20 to +70	°C
		ML610Q421P, ML610Q422P	-40 to +85	
Operating voltage	V _{DD}	—	1.1 to 3.6	V
	AV _{DD}	—	2.2 to 3.6	
Operating frequency (CPU)	f _{OP}	V _{DD} = 1.1 to 3.6V	30k to 36k	Hz
		V _{DD} = 1.3 to 3.6V	30k to 650k	
		V _{DD} = 1.8 to 3.6V	30k to 4.2M	
Low-speed crystal oscillation frequency	f _{XTL}	—	32.768k	Hz
Low-speed crystal oscillation external capacitor	C _{DL}	—	0 to 12	pF
	C _{GL}	—	0 to 12	
High-speed crystal/ceramic oscillation frequency	f _{XTH}	—	4.0M / 4.096M	Hz
High-speed crystal oscillation external capacitor	C _{DH}	—	24	pF
	C _{GH}	—	24	
Capacitor externally connected to V _{DDL} pin	C _{L0}	—	1.0±30%	μF
	C _{L1}	—	0.1±30%	
Capacitor externally connected to V _{DDX} pin	C _X	—	0.1±30%	μF
Capacitors externally connected to V _{L1, 2, 3, 4} pins	C _{a, b, c, d}	—	1.0±30%	μF
Capacitors externally connected across C1 and C2 pins and across C3 and C4 pins	C _{12, C34}	—	1.0±30%	μF

OPERATING CONDITIONS OF FLASH ROM

(V_{SS} = AV_{SS} = 0V)

Parameter	Symbol	Condition	Range	Unit
Operating temperature	T _{OP}	At write/erase	0 to +40	°C
Operating voltage	V _{DD}	At write/erase ^{*1}	2.75 to 3.6	V
	V _{DDL}	At write/erase ^{*1}	2.5 to 2.75	
	V _{PP}	At write/erase ^{*1}	7.7 to 8.3	
Write cycles	C _{EP}	—	80	cycles
Data retention	Y _{DR}	—	10	years

^{*1}: Those voltages must be supplied to V_{DDL} pin and V_{PP} pin when programming and erasing Flash ROM.
V_{PP} pin has an internal pulldown resistor.

DC CHARACTERISTICS (1/5)

(V_{DD} = 1.1 to 3.6V, AV_{DD} = 2.2 to 3.6V, V_{SS} = AV_{SS} = 0V, Ta = -20 to +70°C, Ta = -40 to +85°C for P version, unless otherwise specified) (1/5)

Parameter	Symbol	Condition	Rating			Unit	Measuring circuit
			Min.	Typ.	Max.		
500kHz RC oscillation frequency	f _{RC}	V _{DD} = 1.3 to 3.6V	Ta = 25°C	Typ. -10%	500	Typ. +10%	kHz
			Ta = -20 to +70°C	Typ. -25%	500	Typ. +25%	
			Ta = -40 to +85°C	Typ. -45%	500	Typ. +45%	
PLL oscillation frequency ^{*4}	f _{PLL}	LSCLK = 32.768kHz V _{DD} = 1.8 to 3.6V	-2.5%	8.192	+2.5%	MHz	1
Low-speed crystal oscillation start time ^{*2}	T _{XTL}	—	—	0.3	2	s	
500kHz RC oscillation start time	T _{RC}	—	—	50	500	μs	
High-speed crystal oscillation start time ^{*3}	T _{XTH}	V _{DD} = 1.8 to 3.6V	—	2	20	ms	
PLL oscillation start time	T _{PLL}	V _{DD} = 1.8 to 3.6V	—	1	10		
Low-speed oscillation stop detect time ^{*1}	T _{STOP}	—	0.2	3	20	μs	
Reset pulse width	P _{RST}	—	200	—	—		
Reset noise elimination pulse width	P _{NRST}	—	—	—	0.3	ms	
Power-on reset activation power rise time	T _{POR}	—	—	—	10		

^{*1}: When low-speed crystal oscillation stops for a duration more than the low-speed oscillation stop detect time, the system is reset to shift to system reset mode.

^{*2}: Use 32.768KHz Crystal Oscillator C-001R (Epson Toyocom) with capacitance C_{GL}/C_{DL} = 0pF.

^{*3}: Use 4.096MHz Crystal Oscillator CHC49SFWB (Kyocera).

^{*4}: 1024 clock average.

RESET

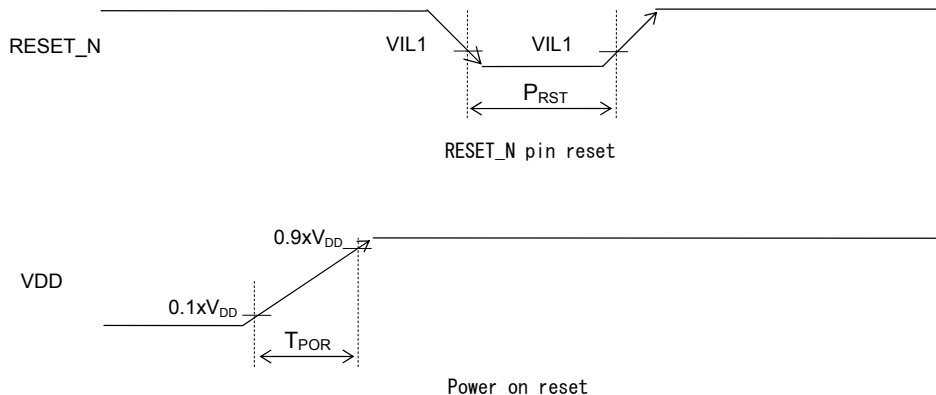

DC CHARACTERISTICS (2/5)

($V_{DD} = 1.1$ to $3.6V$, $AV_{DD} = 2.2$ to $3.6V$, $V_{SS} = AV_{SS} = 0V$, $T_a = -20$ to $+70^\circ C$, $T_a = -40$ to $+85^\circ C$ for P version, unless otherwise specified) (2/5)

Parameter	Symbol	Condition	Rating			Unit	Measuring circuit	
			Min.	Typ.	Max.			
V_{L1} voltage	V_{L1}	$V_{DD} = 3.0V$, $T_j = 25^\circ C$	CN4-0 = 00H	0.89	0.94	0.99	V	1
			CN4-0 = 01H	0.91	0.96	1.01		
			CN4-0 = 02H	0.93	0.98	1.03		
			CN4-0 = 03H	0.95	1.00	1.05		
			CN4-0 = 04H	0.97	1.02	1.07		
			CN4-0 = 05H	0.99	1.04	1.09		
			CN4-0 = 06H	1.01	1.06	1.11		
			CN4-0 = 07H	1.03	1.08	1.13		
			CN4-0 = 08H	1.05	1.10	1.15		
			CN4-0 = 09H	1.07	1.12	1.17		
			CN4-0 = 0AH	1.09	1.14	1.19		
			CN4-0 = 0BH	1.11	1.16	1.21		
			CN4-0 = 0CH	1.13	1.18	1.23		
			CN4-0 = 0DH	1.15	1.20	1.25		
			CN4-0 = 0EH	1.17	1.22	1.27		
			CN4-0 = 0FH	1.19	1.24	1.29		
			CN4-0 = 10H	1.21	1.26	1.31		
			CN4-0 = 11H	1.23	1.28	1.33		
			CN4-0 = 12H	1.25	1.30	1.35		
			CN4-0 = 13H	1.27	1.32	1.37		
			CN4-0 = 14H ^{*1}	1.29	1.34	1.39		
			CN4-0 = 15H ^{*1}	1.31	1.36	1.41		
			CN4-0 = 16H ^{*1}	1.33	1.38	1.43		
			CN4-0 = 17H ^{*1}	1.35	1.40	1.45		
CN4-0 = 18H ^{*1}	1.37	1.42	1.47					
CN4-0 = 19H ^{*1}	1.39	1.44	1.49					
CN4-0 = 1AH ^{*1}	1.41	1.46	1.51					
CN4-0 = 1BH ^{*1}	1.43	1.48	1.53					
CN4-0 = 1CH ^{*1}	1.45	1.50	1.55					
CN4-0 = 1DH ^{*1}	1.47	1.52	1.57					
CN4-0 = 1EH ^{*1}	1.49	1.54	1.59					
CN4-0 = 1FH ^{*1}	1.51	1.56	1.61					
V_{L1} temperature deviation	ΔV_{L1}	$V_{DD} = 3.0V$	—	-1.5	—	mV/°C		
V_{L1} voltage dependency	ΔV_{L1}	$V_{DD} = 1.3$ to $3.6V$	—	5	20	mV/V		
V_{L2} voltage ^{*2}	V_{L2}	$V_{DD} = 3.0V$, $T_j = 25^\circ C$ 500k Ω load ($V_{L4} - V_{SS}$)	Typ. -10%	$V_{L1} \times 2$	Typ. +4%	V		
V_{L3} voltage ^{*2}	V_{L3}	$V_{DD} = 3.0V$, $T_j = 25^\circ C$ 500k Ω load ($V_{L4} - V_{SS}$)	Typ. -10%	$V_{L1} \times 2$	Typ. +4%			
V_{L4} voltage ^{*2}	V_{L4}		Typ. -10%	$V_{L1} \times 3$				Typ. +5%
				$V_{L1} \times 4$				
LCD bias voltage generation time	T_{BIAS}	—	—	—	600	ms		

*1: When using 1/4 bias, the V_{L1} voltage is set to typ. 1.32 V (same voltage as in CN4-0 = 13H).

*2: Boost clock is 2kHz(initial) for the bias generation. C12=C34=1 μ F.

DC CHARACTERISTICS (3/5)

($V_{DD} = 1.1$ to $3.6V$, $AV_{DD} = 2.2$ to $3.6V$, $V_{SS} = AV_{SS} = 0V$, $T_a = -20$ to $+70^\circ C$, $T_a = -40$ to $+85^\circ C$ for P version, unless otherwise specified) (3/5)

Parameter	Symbol	Condition	Rating			Unit	Measuring circuit	
			Min.	Typ.	Max.			
BLD threshold voltage	V_{BLD}	$V_{DD} = 1.35$ to $3.6V$	LD2-0 = 0H	Typ. -2%	1.35	Typ. +2%	V	1
			LD2-0 = 1H		1.4			
			LD2-0 = 2H		1.45			
			LD2-0 = 3H		1.5			
			LD2-0 = 4H		1.6			
			LD2-0 = 5H		1.7			
			LD2-0 = 6H		1.8			
			LD2-0 = 7H		1.9			
			LD2-0 = 8H		2.0			
			LD2-0 = 9H		2.1			
			LD2-0 = 0AH		2.2			
			LD2-0 = 0BH		2.3			
			LD2-0 = 0CH		2.4			
			LD2-0 = 0DH		2.5			
LD2-0 = 0EH	2.7							
LD2-0 = 0FH	2.9							
BLD threshold voltage temperature deviation	ΔV_{BLD}	$V_{DD} = 1.35$ to $3.6V$	—	0	—	%/°C		
Supply current 1	IDD1	CPU: In STOP state. Low-speed/high-speed oscillation: stopped.	$T_a = 25^\circ C$	—	0.15	0.50	μA	
			$T_a = -20$ to $+70^\circ C$	—	—	2.50		
			$T_a = -40$ to $+85^\circ C$	—	—	5.00		
Supply current 2	IDD2	CPU: In HALT state (LTBC, WDT: Operating ^{*3*5}). High-speed oscillation: Stopped. LCD/BIAS circuits: Stopped.	$T_a = 25^\circ C$	—	0.5	1.3	μA	
			$T_a = -20$ to $+70^\circ C$	—	—	3.5		
			$T_a = -40$ to $+85^\circ C$	—	—	6.0		
Supply current 3	IDD3	CPU: In 32.768kHz operating state. ^{*1*3} High-speed oscillation: Stopped. LCD/BIAS circuits: Operating. ^{*2}	$T_a = 25^\circ C$	—	5	7	μA	
			$T_a = -20$ to $+70^\circ C$	—	—	12		
			$T_a = -40$ to $+85^\circ C$	—	—	16		
Supply current 4	IDD4	CPU: In 500kHz CR operating state. LCD/BIAS circuits: Operating. ^{*2}	$T_a = 25^\circ C$	—	70	85	μA	
			$T_a = -20$ to $+70^\circ C$	—	—	100		
			$T_a = -40$ to $+85^\circ C$	—	—	120		
Supply current 5	IDD5	CPU: In 4.096MHz operating state. ^{*2*3} PLL: In oscillating state. LCD/BIAS circuits: Operating. ^{*2} $V_{DD} = 1.8$ to $3.6V$	$T_a = 25^\circ C$	—	0.8	1.0	mA	
			$T_a = -20$ to $+70^\circ C$	—	—	1.2		
			$T_a = -40$ to $+85^\circ C$	—	—	1.2		
Supply current 6	IDD6	CPU: In 4.096MHz operating state. ^{*2}	$T_a = 25^\circ C$	—	1.5	1.6	mA	

		PLL: In oscillating state. *3*4 A/D: In operating state. LCD/BIAS circuits: Operating. *2 V _{DD} = AV _{DD} = 3.0V	Ta = -20 to +70°C	—	—	2.5		
			Ta = -40 to +85°C	—	—	2.5		

*1: When the CPU operating rate is 100% (No HALT state).

*2: All SEGs: off waveform, No LCD panel load, 1/3 bias, 1/3 duty, Frame frequency: Approx. 64 Hz, Bias voltage multiplying clock: 1/128 LSCLK (256Hz)

*3: Use 32.768KHz Crystal Oscillator C-001R (Epson Toyocom) with capacitance C_{GL}/C_{DL}=0pF.

*4: Use 4.096MHz Crystal Oscillator CHC49SFWB (Kyocera).

*5: Significant bits of BLKCON0~BLKCON4 registers are all "1".

DC CHARACTERISTICS (4/5)

(V_{DD} = 1.1 to 3.6V, AV_{DD} = 2.2 to 3.6V, V_{SS} = AV_{SS} = 0V, Ta = -20 to +70°C, Ta = -40 to +85°C for P version, unless otherwise specified) (4/5)

Parameter	Symbol	Condition	Rating			Unit	Measuring circuit
			Min.	Typ.	Max.		
Output voltage 1 (P20-P22/2 nd function is selected) (P30-P36) (P40-P47) (PA0-PA7) ^{*1}	VOH1	IOH1 = -0.5mA, V _{DD} = 1.8 to 3.6V	V _{DD} -0.5	—	—	V	2
		IOH1 = -0.1mA, V _{DD} = 1.3 to 3.6V	V _{DD} -0.3	—	—		
		IOH1 = -0.03mA, V _{DD} = 1.1 to 3.6V	V _{DD} -0.3	—	—		
	VOL1	IOL1 = +0.5mA, V _{DD} = 1.8 to 3.6V	—	—	0.5		
		IOL1 = +0.1mA, V _{DD} = 1.3 to 3.6V	—	—	0.5		
		IOL1 = +0.03mA, V _{DD} = 1.1 to 3.6V	—	—	0.3		
Output voltage 2 (P20-P22/2 nd function is Not selected)	VOH2	IOH1 = -0.5mA, V _{DD} = 1.8 to 3.6V	V _{DD} -0.5	—	—		
		IOH1 = -0.1mA, V _{DD} = 1.3 to 3.6V	V _{DD} -0.3	—	—		
		IOH1 = -0.03mA, V _{DD} = 1.1 to 3.6V	V _{DD} -0.3	—	—		
	VOL2	IOL2 = +5mA, V _{DD} = 1.8 to 3.6V	—	—	0.5		
Output voltage 3 (P40-P41)	VOL3	IOL3 = +3mA, V _{DD} = 2.0 to 3.6V (when I ² C mode is selected)	—	—	0.4		
Output voltage 4 (COM0-15) (SEG0-49)	VOH4	IOH4 = -0.2mA, VL1=1.2V	V _{L4} -0.2	—	—		
	VOMH4	IOMH4 = +0.2mA, VL1=1.2V	—	—	V _{L3} +0.2		
	VOMH4S	IOMH4S = -0.2mA, VL1=1.2V	V _{L3} -0.2	—	—		
	VOM4	IOM4 = +0.2mA, VL1=1.2V	—	—	V _{L2} +0.2		
	VOM4S	IOM4S = -0.2mA, VL1=1.2V	V _{L2} -0.2	—	—		
	VOML4	IOML4 = +0.2mA, VL1=1.2V	—	—	V _{L1} +0.2		
	VOML4S	IOML4S = -0.2mA, VL1=1.2V	V _{L1} -0.2	—	—		
	VOL4	IOL4 = +0.2mA, VL1=1.2V	—	—	0.2		
Output leakage (P20-P22) (P30-P35) (P40-P47) (PA0-PA7) ^{*1}	IOOH	VOH = V _{DD} (in high-impedance state)	—	—	1	μA	3
	IOOL	VOL = V _{SS} (in high-impedance state)	-1	—	—		

Input current 1 (RESET_N)	IIH1	VIH1 = V _{DD}		0	—	1	μA	4
	IIL1	VIL1 = V _{SS}	V _{DD} = 1.8 to 3.6V	-600	-300	-20		
Input current 1 (TEST)	IIH1	VIH1 = V _{DD}	V _{DD} = 1.3 to 3.6V	-600	-300	-10		
			V _{DD} = 1.1 to 3.6V	-600	-300	-2		
			V _{DD} = 1.8 to 3.6V	20	300	600		
Input current 1 (TEST)	IIL1	VIL1 = V _{SS}	V _{DD} = 1.3 to 3.6V	10	300	600		
			V _{DD} = 1.1 to 3.6V	2	300	600		
			V _{DD} = 1.8 to 3.6V	2	30	200		
Input current 2 (NMI) (P00–P03) (P10–P11) (P30–P35) (P40–P47) (PA0–PA7) ^{*1}	IIH2	VIH2 = V _{DD} (when pulled-down)	V _{DD} = 1.3 to 3.6V	0.2	30	200		
			V _{DD} = 1.1 to 3.6V	0.01	30	200		
			V _{DD} = 1.8 to 3.6V	-200	-30	-2		
	IIL2	VIL2 = V _{SS} (when pulled-up)	V _{DD} = 1.3 to 3.6V	-200	-30	-0.2		
			V _{DD} = 1.1 to 3.6V	-200	-30	-0.01		
			V _{DD} = 1.8 to 3.6V	-200	-30	-0.01		
	IIH2Z	VIH2 = V _{DD} (in high-impedance state)	—	—	1			
IIL2Z	VIL2 = V _{SS} (in high-impedance state)	-1	—	—				

*1: ML610Q421 only

DC CHARACTERISTICS (5/5)(V_{DD} = 1.1 to 3.6V, AV_{DD} = 2.2 to 3.6V, V_{SS} = AV_{SS} = 0V, Ta = -20 to +70°C, Ta = -40 to +85°C for P version, unless otherwise specified) (5/5)

Parameter	Symbol	Condition	Rating			Unit	Measuring circuit
			Min.	Typ.	Max.		
Input voltage 1 (RESET_N) (TEST) (NMI) (P00–P03) (P10–P11) (P31–P35) (P40–P43) (P45–P47) (PA0–PA7) ^{*1}	VIH1	V _{DD} = 1.3 to 3.6V	0.7 ×V _{DD}	—	V _{DD}	V	5
		V _{DD} = 1.1 to 3.6V	0.7 ×V _{DD}	—	V _{DD}		
	VIL1	V _{DD} = 1.3 to 3.6V	0	—	0.3 ×V _{DD}		
		V _{DD} = 1.1 to 3.6V	0	—	0.2 ×V _{DD}		
Input voltage 2 (P30, P44)	VIH2	—	0.7 ×V _{DD}	—	V _{DD}		
	VIL2	—	0	—	0.3 ×V _{DD}		
Input pin capacitance (NMI) (P00–P03) (P10–P11) (P30–P35) (P40–P47) (PA0–PA7) ^{*1}	CIN	f = 10kHz V _{rms} = 50mV Ta = 25°C	—	—	5	pF	—

*1: ML610Q421 only

MEASURING CIRCUITS

MEASURING CIRCUIT 1

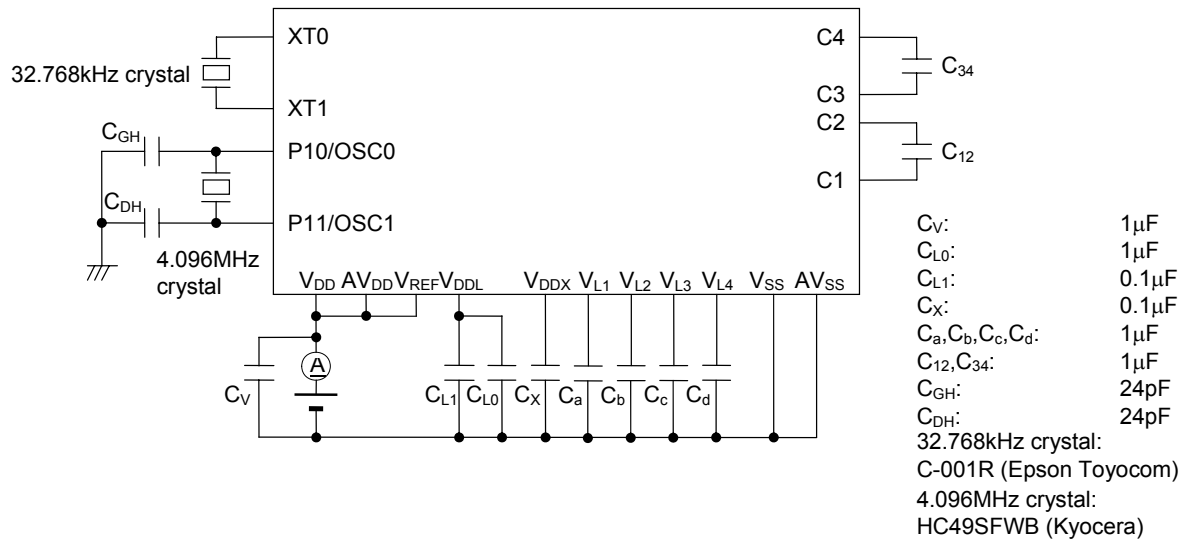

MEASURING CIRCUIT 2

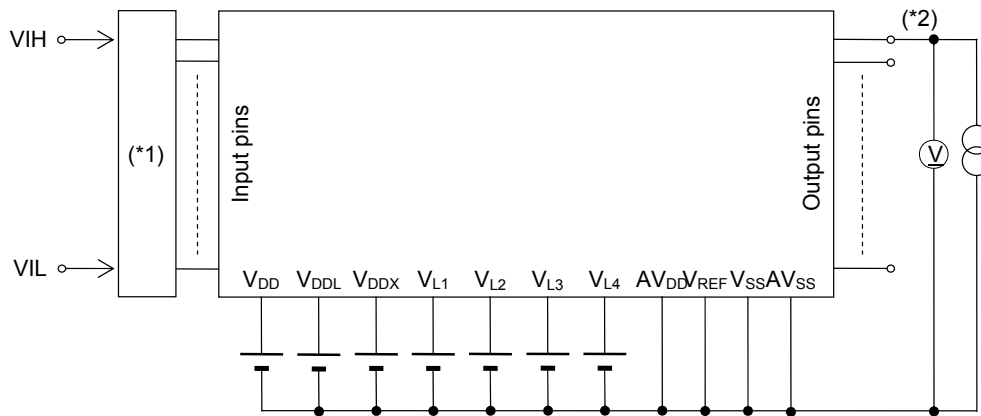

(*1) Input logic circuit to determine the specified measuring conditions.

(*2) Measured at the specified output pins.

MEASURING CIRCUIT 3

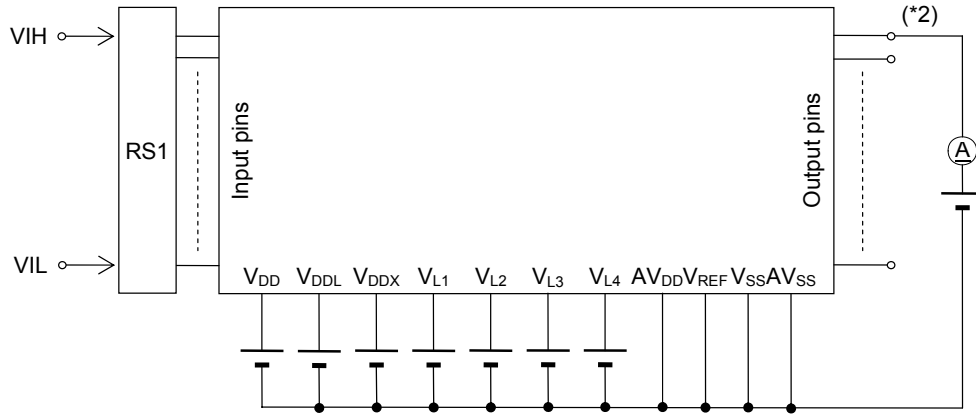

*1: Input logic circuit to determine the specified measuring conditions.
 *2: Measured at the specified output pins.

MEASURING CIRCUIT 4

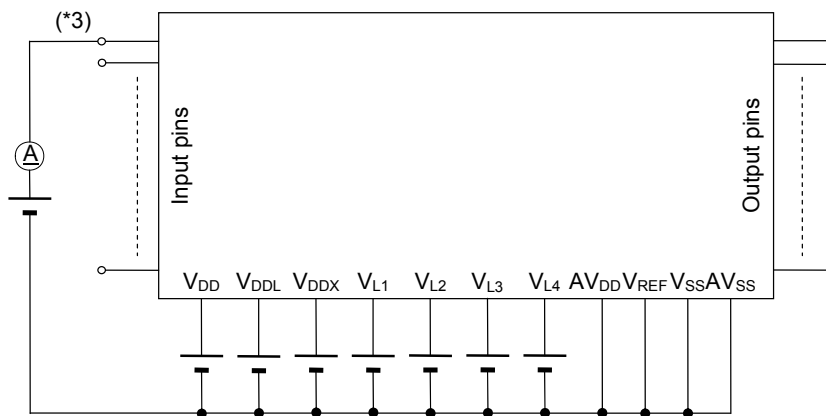

*3: Measured at the specified output pins.

MEASURING CIRCUIT 5

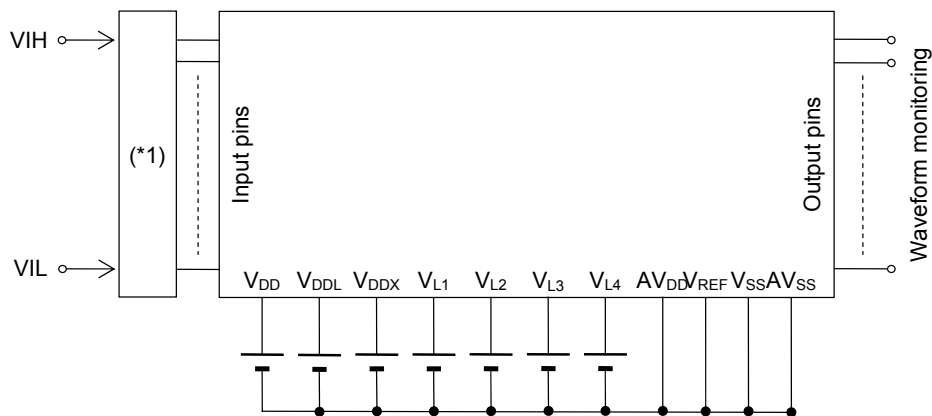

*1: Input logic circuit to determine the specified measuring conditions.

AC CHARACTERISTICS (External Interrupt)

($V_{DD} = 1.1$ to $3.6V$, $AV_{DD} = 2.2$ to $3.6V$, $V_{SS} = AV_{SS} = 0V$, $T_a = -20$ to $+70^{\circ}C$, $T_a = -40$ to $+85^{\circ}C$ for P version, unless otherwise specified)

Parameter	Symbol	Condition	Rating			Unit
			Min.	Typ.	Max.	
External interrupt disable period	T_{NUL}	Interrupt: Enabled (MIE = 1), CPU: NOP operation System clock: 32.768kHz	76.8	—	106.8	μs

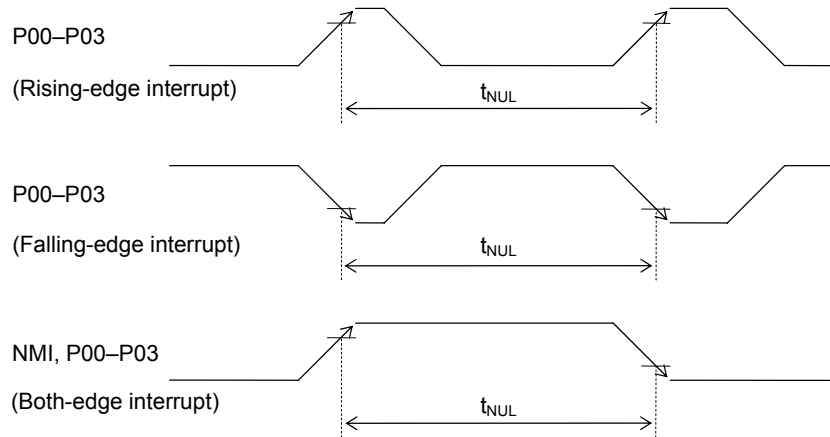

AC CHARACTERISTICS (UART)

($V_{DD} = 1.3$ to $3.6V$, $AV_{DD} = 2.2$ to $3.6V$, $V_{SS} = AV_{SS} = 0V$, $T_a = -20$ to $+70^{\circ}C$, $T_a = -40$ to $+85^{\circ}C$ for P version, unless otherwise specified)

Parameter	Symbol	Condition	Rating			Unit
			Min.	Typ.	Max.	
Transmit baud rate	t_{TBRT}	—	—	BRT* ¹	—	s
Receive baud rate	t_{RBRT}	—	BRT* ¹ -3%	BRT* ¹	BRT* ¹ +3%	s

*1: Baud rate period (including the error of the clock frequency selected) set with the UART0 baud rate register (UA0BRTL,H) and the UART0 mode register 0 (UA0MOD0).

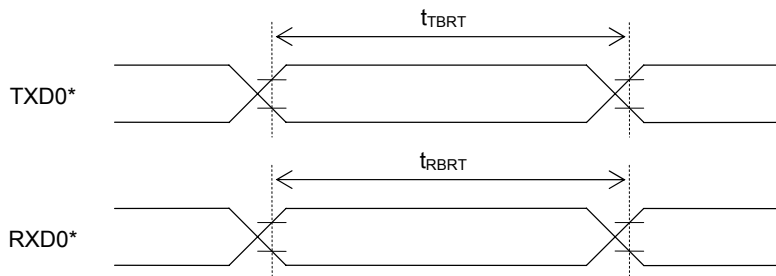

*: Indicates the secondary function of the port.

AC CHARACTERISTICS (Synchronous Serial Port)

($V_{DD} = 1.3$ to $3.6V$, $AV_{DD} = 2.2$ to $3.6V$, $V_{SS} = AV_{SS} = 0V$, $T_a = -20$ to $+70^\circ C$, $T_a = -40$ to $+85^\circ C$ for P version, unless otherwise specified)

Parameter	Symbol	Condition	Rating			Unit
			Min.	Typ.	Max.	
SCLK input cycle (slave mode)	t_{SCYC}	When RC oscillation is active* ² ($V_{DD} = 1.3$ to $3.6V$)	10	—	—	μs
		When high-speed oscillation is active* ³ ($V_{DD} = 1.8$ to $3.6V$)	1	—	—	μs
SCLK output cycle (master mode)	t_{SCYC}	—	—	SCLK* ¹	—	s
SCLK input pulse width (slave mode)	t_{SW}	When RC oscillation is active* ² ($V_{DD} = 1.3$ to $3.6V$)	4	—	—	μs
		When high-speed oscillation is active* ³ ($V_{DD} = 1.8$ to $3.6V$)	0.4	—	—	μs
SCLK output pulse width (master mode)	t_{SW}	—	SCLK* ¹ $\times 0.4$	SCLK* ¹ $\times 0.5$	SCLK* ¹ $\times 0.6$	s
SOUT output delay time (slave mode)	t_{SD}	When RC oscillation is active* ² ($V_{DD} = 1.3$ to $3.6V$)	—	—	500	ns
		When high-speed oscillation is active* ³ ($V_{DD} = 1.8$ to $3.6V$)	—	—	240	
SOUT output delay time (master mode)	t_{SD}	When RC oscillation is active* ² ($V_{DD} = 1.3$ to $3.6V$)	—	—	500	ns
		When high-speed oscillation is active* ³ ($V_{DD} = 1.8$ to $3.6V$)	—	—	240	
SIN input setup time (slave mode)	t_{SS}	—	80	—	—	ns
SIN input setup time (master mode)	t_{SS}	When RC oscillation is active* ² ($V_{DD} = 1.3$ to $3.6V$)	500	—	—	ns
		When high-speed oscillation is active* ³ ($V_{DD} = 1.8$ to $3.6V$)	240	—	—	
SIN input hold time	t_{SH}	When RC oscillation is active* ² ($V_{DD} = 1.3$ to $3.6V$)	300	—	—	ns
		When high-speed oscillation is active* ³ ($V_{DD} = 1.8$ to $3.6V$)	80	—	—	

*¹: Clock period selected with S0CK3–0 of the serial port 0 mode register (SIO0MOD1)

*²: When RC oscillation is selected with OSCM1–0 of the frequency control register (FCON0)

*³: When Crystal/ceramic oscillation, built-in PLL oscillation, or external clock input is selected with OSCM1–0 of the frequency control register (FCON0)

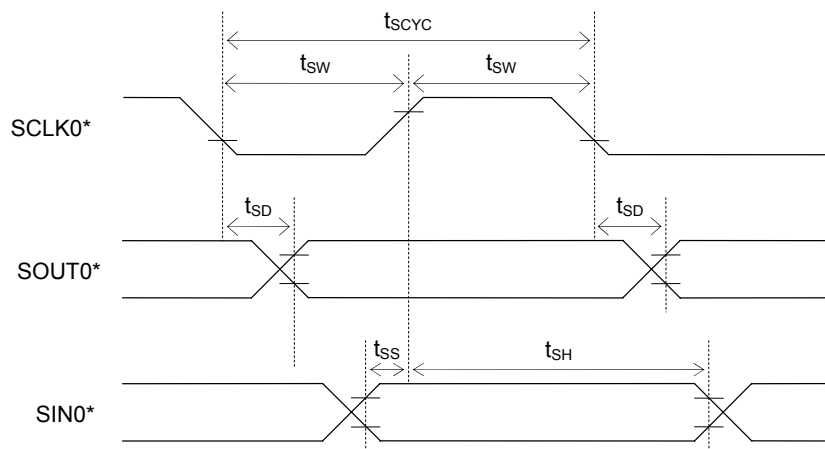

*: Indicates the secondary function of the port.

AC CHARACTERISTICS (I²C Bus Interface: Standard Mode 100kHz)(V_{DD} = 1.8 to 3.6V, AV_{DD} = 2.2 to 3.6V, V_{SS} = AV_{SS} = 0V, Ta = -20 to +70°C, Ta = -40 to +85°C for P version, unless otherwise specified)

Parameter	Symbol	Condition	Rating			Unit
			Min.	Typ.	Max.	
SCL clock frequency	f _{SCL}	—	0	—	100	kHz
SCL hold time (start/restart condition)	t _{HD:STA}	—	4.0	—	—	μs
SCL "L" level time	t _{LOW}	—	4.7	—	—	μs
SCL "H" level time	t _{HIGH}	—	4.0	—	—	μs
SCL setup time (restart condition)	t _{SU:STA}	—	4.7	—	—	μs
SDA hold time	t _{HD:DAT}	—	0	—	—	μs
SDA setup time	t _{SU:DAT}	—	0.25	—	—	μs
SDA setup time (stop condition)	t _{SU:STO}	—	4.0	—	—	μs
Bus-free time	t _{BUF}	—	4.7	—	—	μs

AC CHARACTERISTICS (I²C Bus Interface: Fast Mode 400kHz)(V_{DD} = 1.8 to 3.6V, AV_{DD} = 2.2 to 3.6V, V_{SS} = AV_{SS} = 0V, Ta = -20 to +70°C, Ta = -40 to +85°C for P version, unless otherwise specified)

Parameter	Symbol	Condition	Rating			Unit
			Min.	Typ.	Max.	
SCL clock frequency	f _{SCL}	—	0	—	400	kHz
SCL hold time (start/restart condition)	t _{HD:STA}	—	0.6	—	—	μs
SCL "L" level time	t _{LOW}	—	1.3	—	—	μs
SCL "H" level time	t _{HIGH}	—	0.6	—	—	μs
SCL setup time (restart condition)	t _{SU:STA}	—	0.6	—	—	μs
SDA hold time	t _{HD:DAT}	—	0	—	—	μs
SDA setup time	t _{SU:DAT}	—	0.1	—	—	μs
SDA setup time (stop condition)	t _{SU:STO}	—	0.6	—	—	μs
Bus-free time	t _{BUF}	—	1.3	—	—	μs

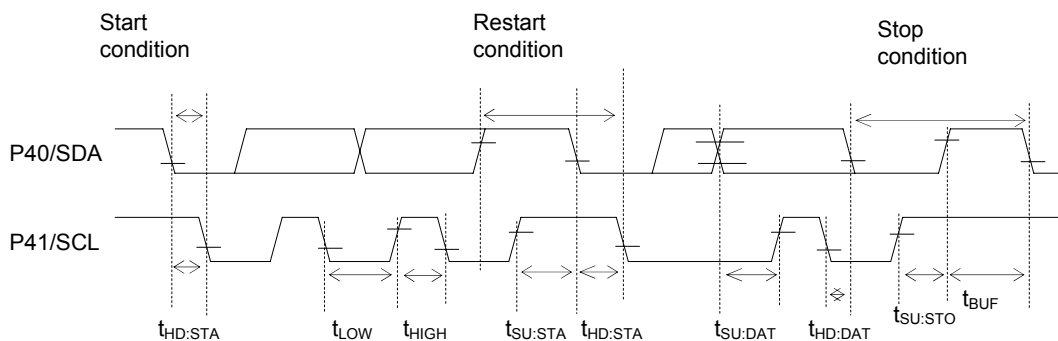

AC CHARACTERISTICS (RC Oscillation A/D Converter)

(V_{DD} = 1.3 to 3.6V, AV_{DD} = 2.2 to 3.6V, V_{SS} = AV_{SS} = 0V, Ta = -20 to +70°C, Ta = -40 to +85°C for P version, unless otherwise specified)

Parameter	Symbol	Condition	Rating			Unit
			Min.	Typ.	Max.	
Resistors for oscillation	RS0, RS1, RT0, RT0-1, RT1	CS0, CT0, CS1 ≥ 740pF	1	—	—	kΩ
Oscillation frequency VDD = 1.5V	f _{OSC1}	Resistor for oscillation = 1kΩ	209.4	330.6	435.1	kHz
	f _{OSC2}	Resistor for oscillation = 10kΩ	41.29	55.27	64.16	kHz
	f _{OSC3}	Resistor for oscillation = 100kΩ	4.71	5.97	7.06	kHz
RS to RT oscillation frequency ratio ^{*1} VDD = 1.5V	Kf1	RT0, RT0-1, RT1 = 1kHz	5.567	5.982	6.225	—
	Kf2	RT0, RT0-1, RT1 = 10kHz	0.99	1	1.01	—
	Kf3	RT0, RT0-1, RT1 = 100kHz	0.104	0.108	0.118	—
Oscillation frequency VDD = 3.0V	f _{OSC1}	Resistor for oscillation = 1kΩ	407.3	486.7	594.6	kHz
	f _{OSC2}	Resistor for oscillation = 10kΩ	49.76	59.28	72.76	kHz
	f _{OSC3}	Resistor for oscillation = 100kΩ	5.04	5.993	7.04	kHz
RS to RT oscillation frequency ratio ^{*1} VDD = 3.0V	Kf1	RT0, RT0-1, RT1 = 1kHz	8.006	8.210	8.416	—
	Kf2	RT0, RT0-1, RT1 = 10kHz	0.99	1	1.01	—
	Kf3	RT0, RT0-1, RT1 = 100kHz	0.100	0.108	0.115	—

*1: Kfx is the ratio of the oscillation frequency by the sensor resistor to the oscillation frequency by the reference resistor on the same conditions.

$$Kfx = \frac{f_{oscx}(RT0-CS0 \text{ oscillation})}{f_{oscx}(RS0-CS0 \text{ oscillation})}, \frac{f_{oscx}(RT0-1-CS0 \text{ oscillation})}{f_{oscx}(RS0-CS0 \text{ oscillation})}, \frac{f_{oscx}(RT1-CS1 \text{ oscillation})}{f_{oscx}(RS1-CS1 \text{ oscillation})}$$

(x = 1, 2, 3)

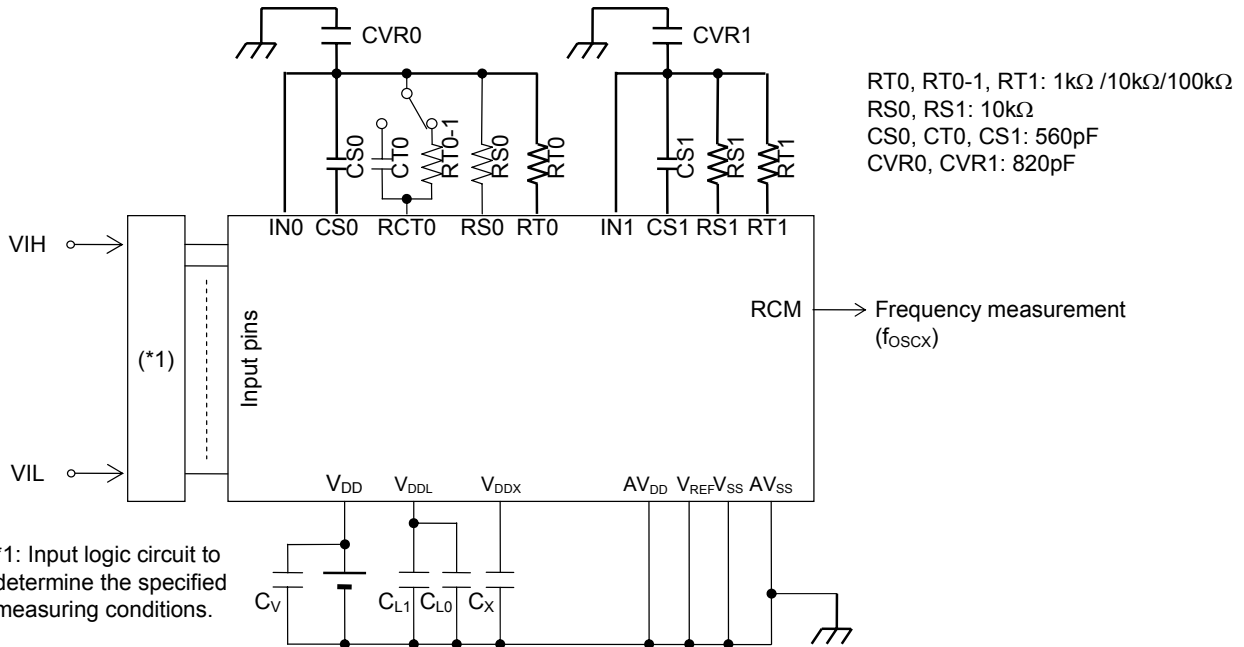

Note:

- Please have the shortest layout for the common node (wiring patterns which are connected to the external capacitors, resistors and IN0/IN1 pin), including CVR0/CVR1. Especially, do not have long wire between IN0/IN1 and RS0/RS1. The coupling capacitance on the wires may occur incorrect A/D conversion. Also, please do not have signals which may be a source of noise around the node.
- When RT0/RT1 (Thermistor and etc.) requires long wiring due to the restricted placement, please have VSS(GND) trace next to the signal.
- Please make wiring to components (capacitor, resistor and etc.) necessary for objective measurement. Wiring to reserved components may affect to the A/D conversion operation by noise the components itself may have.

Electrical Characteristics of Successive Approximation Type A/D Converter

($V_{DD} = 1.8$ to $3.6V$, $AV_{DD} = 2.2$ to $3.6V$, $V_{SS} = AV_{SS} = 0V$, $T_a = -20$ to $+70^\circ C$, $T_a = -40$ to $+85^\circ C$ for P version, unless otherwise specified)

Parameter	Symbol	Condition	Rating			Unit
			Min.	Typ.	Max.	
Resolution	n	—	—	—	12	bit
Integral non-linearity error	IDL	$2.7V \leq V_{REF} \leq 3.6V$	-4	—	+4	LSB
		$2.2V \leq V_{REF} \leq 2.7V$	-6	—	+6	
Differential non-linearity error	DNL	$2.7V \leq V_{REF} \leq 3.6V$	-3	—	+3	
		$2.2V \leq V_{REF} \leq 2.7V$	-5	—	+5	
Zero-scale error	V_{OFF}	—	-6	—	+6	
Full-scale error	FSE	—	-6	—	+6	
Reference voltage	V_{REF}	—	2.2	—	AV_{DD}	V
Conversion time	t_{CONV}	SACK = 0 (HSCLK = 375kHz to 625kHz)	—	25	—	ϕ/CH
		SACK = 1 (HSCLK = 1.5MHz to 4.2MHz)	—	112	—	

ϕ : Period of high-speed clock (HSCLK)

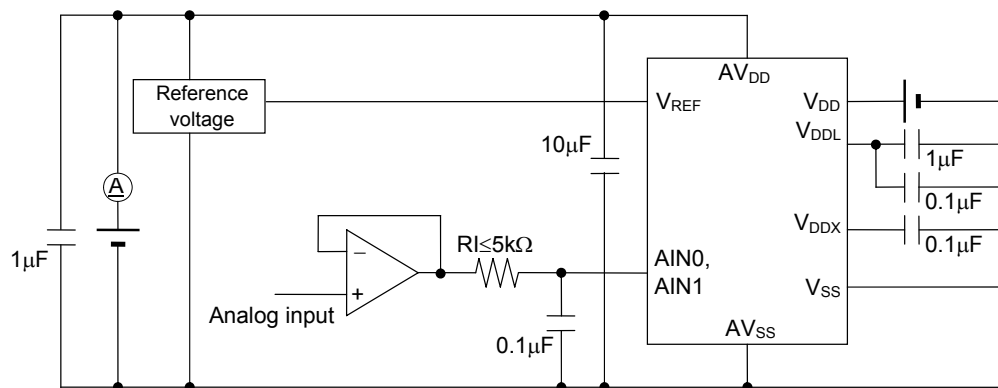

Package Dimensions

(Unit: mm)

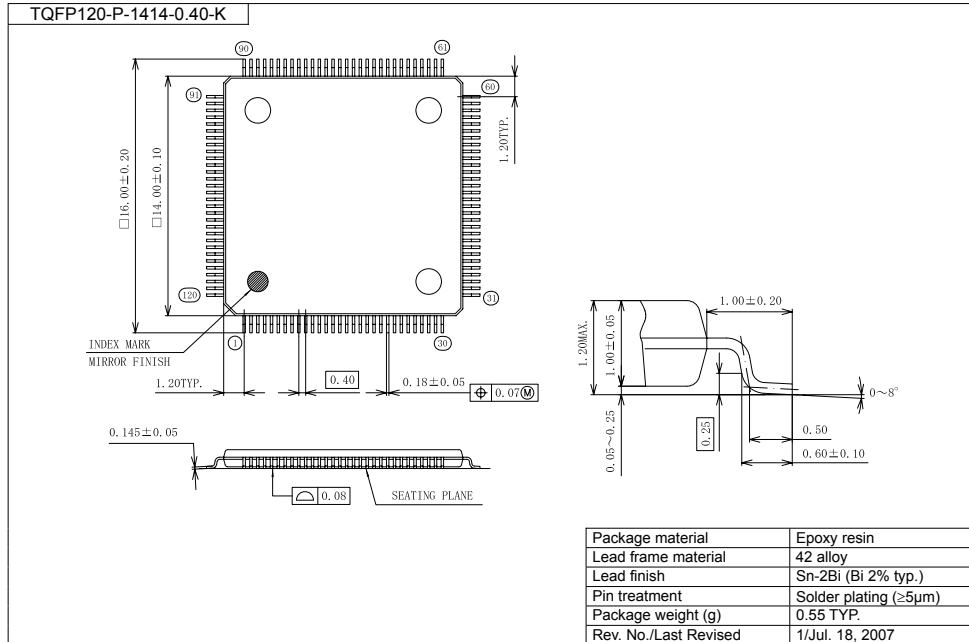

Notes for Mounting the Surface Mount Type Package

The surface mount type packages are very susceptible to heat in reflow mounting and humidity absorbed in storage. Therefore, before you perform reflow mounting, contact our responsible sales person for the product name, package name, pin number, package code and desired mounting conditions (reflow method, temperature and times).

REVISION HISTORY

Document No.	Date	Page		Description
		Previous Edition	Current Edition	
FEDL610Q421-01	Jul. 29, 2009	–	–	Formally edition 1

NOTICE

1. The information contained herein can change without notice owing to product and/or technical improvements. Before using the product, please make sure that the information being referred to is up-to-date.
2. The outline of action and examples for application circuits described herein have been chosen as an explanation for the standard action and performance of the product. When planning to use the product, please ensure that the external conditions are reflected in the actual circuit, assembly, and program designs.
3. When designing your product, please use our product below the specified maximum ratings and within the specified operating ranges including, but not limited to, operating voltage, power dissipation, and operating temperature.
4. OKI SEMICONDUCTOR assumes no responsibility or liability whatsoever for any failure or unusual or unexpected operation resulting from misuse, neglect, improper installation, repair, alteration or accident, improper handling, or unusual physical or electrical stress including, but not limited to, exposure to parameters beyond the specified maximum ratings or operation outside the specified operating range.
5. Neither indemnity against nor license of a third party's industrial and intellectual property right, etc. is granted by us in connection with the use of the product and/or the information and drawings contained herein. No responsibility is assumed by us for any infringement of a third party's right which may result from the use thereof.
6. The products listed in this document are intended for use in general electronics equipment for commercial applications (e.g., office automation, communication equipment, measurement equipment, consumer electronics, etc.). These products are not, unless specifically authorized by OKI SEMICONDUCTOR authorized for use in any system or application that requires special or enhanced quality and reliability characteristics nor in any system or application where the failure of such system or application may result in the loss or damage of property, or death or injury to humans.
Such applications include, but are not limited to, traffic and automotive equipment, safety devices, aerospace equipment, nuclear power control, medical equipment, and life-support systems.
7. Certain products in this document may need government approval before they can be exported to particular countries. The purchaser assumes the responsibility of determining the legality of export of these products and will take appropriate and necessary steps at their own expense for these.
8. No part of the contents contained herein may be reprinted or reproduced without our prior permission.

Copyright 2008 OKI SEMICONDUCTOR CO., LTD.