

GFB 40 x 50 x 32 MM SERIES

DIMENSIONS DRAWING

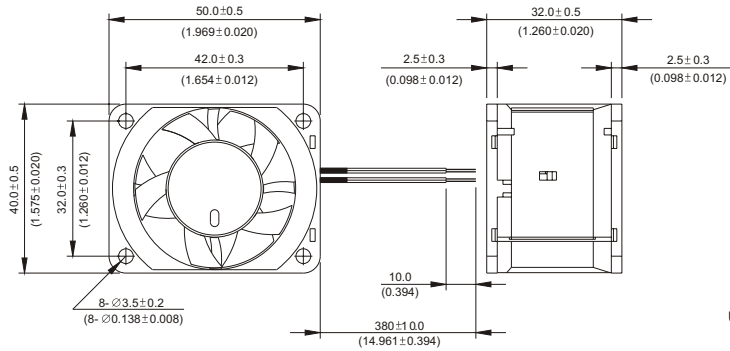

UNIT: mm
(INCH)

- * Bearing Type
Ball Bearings
- * Material
Impeller & Frame : Plastic(UL 94V-0)
- * Lead Wires :
UL 1061 AWG #24 OR Equivalent
Red Wire Positive(+)
Black Wire Negative(-)
- * Weight : 45g (1.59 OZ)

P & Q CURVE (AT RATED VOLTAGE)

MOUNTING PANEL CUTOUT

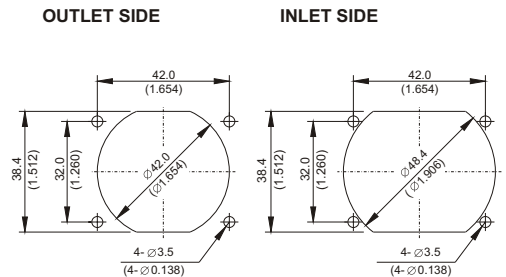
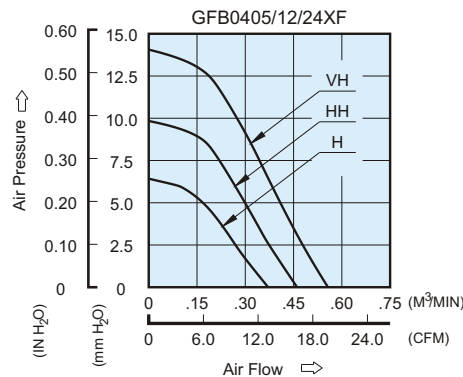

UNIT: mm
(INCH)

MODEL		Rated Voltage	Operating Voltage Range	Rated Current	Rated Input Power	Speed (Front /Rear)	Maximum Air Flow		Maximum Air Pressure		Noise
PART NO.	FUNCTION	VDC	VDC	Amp	Watt	R.P.M.	m ³ /min	CFM	mmH ₂ O	IN H ₂ O	dB-A
GFB0405HF	-R00 / -F00	5	4.5 to 5.5	0.36	1.80	6500/6200	0.371	13.10	6.42	0.253	41.0
GFB0412HF	-R00 / -F00	12	7.0 to 13.2	0.14	1.68						
GFB0424HF	-R00 / -F00	24	14.0 to 26.4	0.12	2.88						
GFB0405HHF	-R00 / -F00	5	4.5 to 5.5	0.66	3.30	8000/7650	0.461	16.28	9.84	0.387	46.5
GFB0412HHF	-R00 / -F00	12	7.0 to 13.2	0.23	2.76						
GFB0424HHF	-R00 / -F00	24	14.0 to 26.4	0.16	3.84						
GFB0412VHF	-R00 / -F00	12	7.0 to 13.2	0.36	4.32	9500/9100	0.557	19.67	14.06	0.554	51.5
GFB0424VHF	-R00 / -F00	24	14.0 to 26.4	0.22	5.28						

* Function type is optional.
 * The max. air flow and the speed are measured in free air ; max. air pressure is measured at zero air flow.
 * Noise is measured in anechoic chamber in free air, one meter from intake side.
 * All readings are typical values at rated voltage.
 * Specifications are subject to change without notice.