

**ebm-papst St. Georgen GmbH & Co. KG**

Hermann-Papst-Straße 1

78112 St. Georgen

Phone: +49 7724 81-0

Fax: +49 7724 81-1309

www.ebmpapst.com

info2@de.ebmpapst.com

Nominal data

| Type | 614 NGL | |
|--------------------------|----------------------|----------|
| Nominal voltage | [VDC] | 24 |
| Nominal voltage range | [VDC] | 18 .. 28 |
| Speed | [min ⁻¹] | 2500 |
| Power input | [W] | 1.0 |
| Min. ambient temperature | [°C] | -20 |
| Max. ambient temperature | [°C] | 70 |
| Air flow | [m ³ /h] | 21 |
| Sound power level | [B] | 3.6 |
| Sound pressure level | [dB(A)] | 16 |

ml = max. load · me = max. efficiency · rfa = running at free air · cs = customer specs · cu = customer unit
Subject to alterations

Technical features

| | |
|--|---|
| Dimensions | 60 x 60 x 25 mm |
| General description | Electronic commutation completely integrated. |
| Connection line | Single strands AWG 22, TR 64, bared and tin-plated. |
| Locked-rotor protection | With electronic blocking and overload protection |
| Direction of protection | Right, looking at rotor |
| Direction of air flow | Air exhaust over bars |
| Bearing | Sintec sleeve bearing |
| Lifetime L10 at 40 °C | 80000 h |
| Lifetime L10 at maximum temperature | 40000 h |
| Mass | 0.066 kg |
| Housing material | Fiberglass-reinforced PBTP plastic |
| Material of impeller | Fiberglass-reinforced PA plastic |
| Motor protection | Protected against reverse polarity and locking. |
| Approval | VDE, CSA, UL, CE |

Product drawing

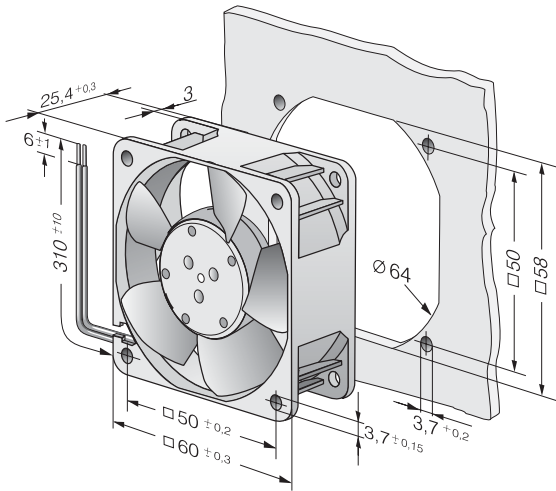

Charts: Air flow

