

# 0.4 mm Pitch, 1.5 mm Mated Height, Board-to-Fine Coaxial Cable Connectors

## DF36 Series

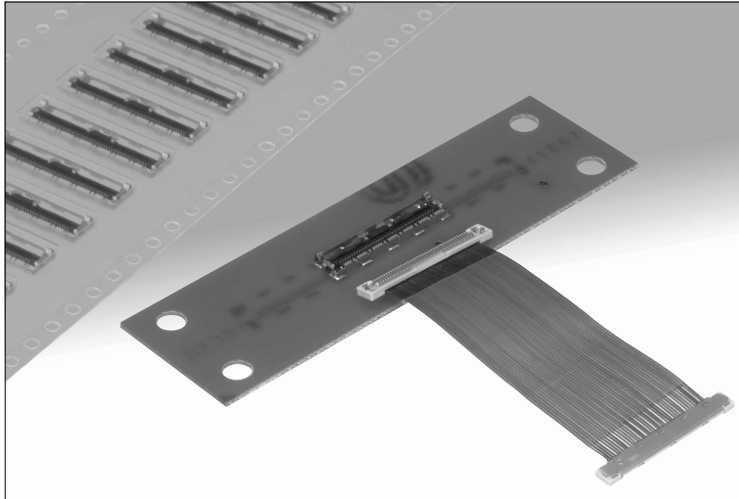

### ■ Features

#### 1. Small mated height and board occupied space

Small pitch (0.4mm) and mated height (1.5mm) allows use in space-restricted areas.

Standard type: mated height 1.5 mm, depth 4.4 mm

Saving space type: mated height 1.5 mm, depth 2.8 mm

Plug : Height 1.33 mm, depth 2.8 mm

#### 2. Enhanced shielding and ground connections

Metal covers on the plug and receptacle connect to each other with a reliable multi-point ground contacts, assuring reliable ground connection and EMC protection.

#### 3. Reliable lock

Fully mated condition is assured with reliable locks at 4 locations, confirming it with a distinct tactile click.

#### 4. Reliable electrical and mechanical connection

Despite its small mated height, unique contact configuration assures highly reliable connection, with effective mating length of 0.4 mm.

#### 5. Solder wicking prevention

Nickel barriers prevent solder wicking in the critical contact areas.

#### 6. Durable plug construction

Formed metal shells on the top and side surfaces form a strong and rigid assembly.

### ■ Receptacle for conductivity tests

We have a line-up of connectors for inspection, usable for electrical testing of both standard type and space saving type.

High contact reliability –  
Effective mating length of 0.4 mm

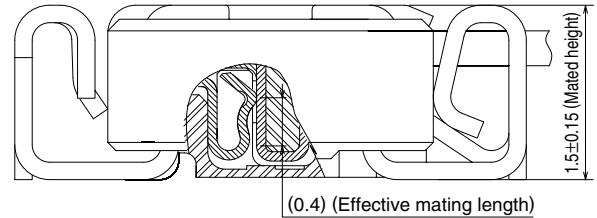

Enhanced shielding (standard type)

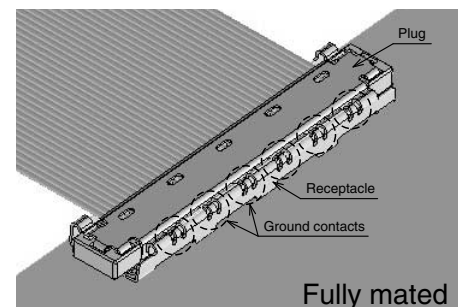

Fully mated  
Multi-point contacts

Enhanced shielding (Space - Saving type)

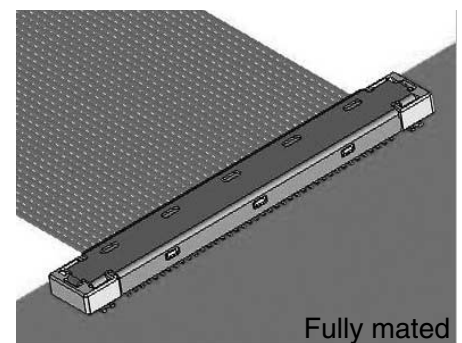

Fully mated

4-point lock: 2 points at each end

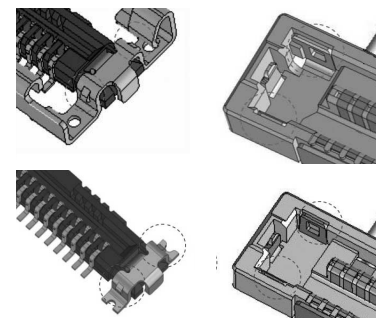

Distinct tactile click

## ■ Product Specifications

Ratings	Current rating	0.25A(AWG#42) 0.25A(AWG#44) (Note3) 0.1A(AWG#46)	Operating temperature range Operating humidity range	-35 to +85°C (Note 1) 20 to 80%
	Voltage rating	30 V AC	Storage temperature range Storage humidity range	-10 to +60°C (Note 2) 40 to 70% (Note 2)

Item	Specification	Conditions
1. Insulation resistance	50 MΩ min	100 V DC
2. Withstanding voltage	No flashover or insulation breakdown	100 V AC / one minute
3. Contact resistance	Signal: 80 mΩ max., Ground: 80 mΩ max.	100 mA (DC or 1,000 Hz)
4. Vibration	No electrical discontinuity of 1 μs or longer No damage, cracks or parts dislocation.	Frequency: 10 to 55 Hz, single amplitude of 0.75 mm, 10 cycles in each of the 3 axial directions
5. Humidity	Contact resistance (Change from initial value) 50 mΩ max. Insulation resistance: 25 MΩ min. No damage, cracks or parts dislocation.	96 hours at 40 ±2°C, and humidity of 90 to 95%
6. Temperature cycle	Contact resistance (Change from initial value) 50 mΩ max. Insulation resistance: 25 MΩ min. No damage, cracks or parts dislocation.	Temperature: -55°C → 5 to 35°C → 85°C → 5 to 35°C Time: 30 min. → 2 to 3 min. → 30 min. → 2 to 3 min. 5 cycles
7. Durability	Contact resistance (Change from initial value) 50 mΩ max. No damage, cracks or parts dislocation.	30 cycles
8. Resistance to soldering heat	No deformation of components affecting performance.	Reflow: At the recommended temperature profile Manual soldering: 350°C for 3 seconds

Note 1: Includes temperature rise caused by current flow.

Note 2: The term "storage" refers to products stored for a long period prior to mounting and use.

The operating temperature and humidity range covers the non-conducting condition of connectors after board mounting and the temporary storage conditions of transportation, etc.

Note 3: With only the connector portion at an elevated temperature level, the rated current value is set.

Note 4: Information contained in this catalog represents general requirements for this Series. Contact us for the drawings and specifications for a specific part number shown.

## ■ Materials

Item	Part	Material	Finish	Remarks
Receptacle (Standard)	Insulator	LCP	Color: Black	UL94V-0
	Contacts	Phosphor bronze	Gold plated	—
	Metal cover	Phosphor bronze	Tin plated	—
Plug (Standard)	Insulator	LCP	Color: Natural (Beige), Black	UL94V-0
	Contacts	Phosphor bronze	Gold plated	—
	Metal shell	Phosphor bronze	Tin plated	—

Item	Part	Material	Finish	Remarks
Receptacle (Space-saving)	Insulator	LCP	Color: Black	UL94V-0
	Contacts	Phosphor bronze	Gold plated	—
	Metal cover	Phosphor bronze	Gold plated	—
Plug (Space-saving)	Insulator	LCP	Color: Natural (Beige), Black	UL94V-0
	Contacts	Phosphor bronze	Gold plated	—
	Metal shell	Phosphor bronze	Gold plated	—

## ■ Ordering information

### ● Connector

**DF 36 A J - \* S - 0.4 V (\*\*)**  
 ① ② ③ ④ ⑤ ⑥ ⑦ ⑧ ⑨

**DF 36 A J - \* P - SHL**  
 ① ② ③ ④ ⑤ ⑥ ⑩

① Series name : DF	④ Insulator type J : Receptacles for conductivity tests Blank : Standard or space-saving P : Single-row plug	⑥ Connector style S : Single-row receptacle P : Single-row plug
② Series No. : 36		⑦ Contact pitch: 0.4 mm
③ Connector style Receptacle/shell A : Standard Blank : Space-saving Plug Blank : Standard	⑤ Number of contacts Standard : 15 to 50 Space-saving : 15 to 25 Receptacles for conductivity tests : 15 to 50	⑧ Termination type V : Straight SMT SD : Fine coaxial cable plug
		⑨ Packaging (51) : Embossed tape packaging
		⑩ Installation item (separate) SHL : Metal cover

## ■ Combinations

### ● Standard use

DF36(A)-\*S-0.4V(\*\*) + DF36(A)-\*P-ASSY  
 ( DF36-\*P-0.4SD(\*\*) )  
 ( DF36(A)-\*P-SHL )

Note: The product specification of the above combination is shown on page 2.

### ● Receptacle test

DF36(A)-\*S-0.4V(\*\*) + DF36(A)J-\*P-ASSY ·· Note  
 ( DF36-\*P-0.4SD(\*\*) )  
 ( DF36(A)J-\*P-SHL )

Note: This harness item is only usable for the receptacle test.

For the product specification of the above combination, please contact our sales department.

### ● Plug test

DF38(A)J-\*S-0.4V(\*\*) ·· Note + DF36(A)-\*P-ASSY  
 ( DF36-\*P-0.4SD(\*\*) )  
 ( DF36(A)-\*P-SHL )

Note: This harness item is only usable for the plug test.

For the product specification of the above combination, please contact our sales department.

※: ASSY means a harness item.

## ■Receptacles - Standard, with metal cover

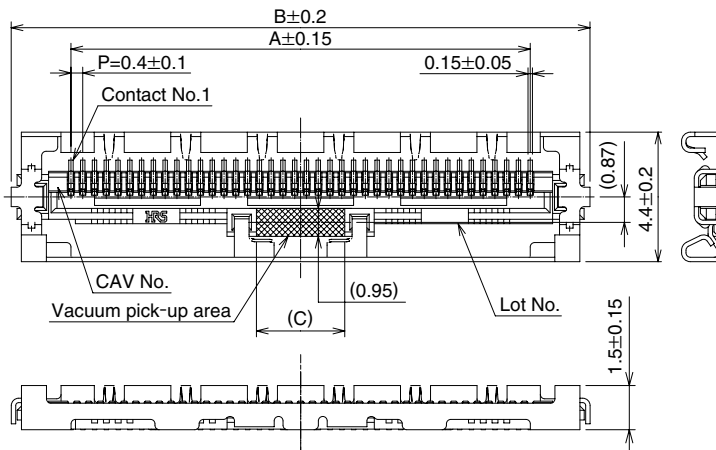

All dimensions: mm

Part Number	CL No.	Number of Contacts	A	B	C
DF36A-15S-0.4V(**)	662-4509-5-**-	15	9.6	13.66	2.6
DF36A-25S-0.4V(**)	662-4011-4-**-	25	9.6	13.66	2.6
DF36A-30S-0.4V(**)	662-4017-0-**-	30	11.6	15.66	3.0
DF36A-40S-0.4V(**)	662-4003-6-**-	40	15.6	19.66	3.0
DF36A-45S-0.4V(**)	662-4008-0-**-	45	17.6	21.66	3.0
DF36A-50S-0.4V(**)	662-4043-0-**-	50	17.6	21.66	3.0

[Specifications number] - \*\*, (\*\*)  
 (51) : Embossed tape packaging  
 (4,000 pieces per reel)

Note 1: Tape and reel packaging (4,000 pieces/reel).

Order by number of reels.

Note 2: The 15 pos. does not have a lot stamp.

## ■Recommended PCB mounting pattern

●15 pos.

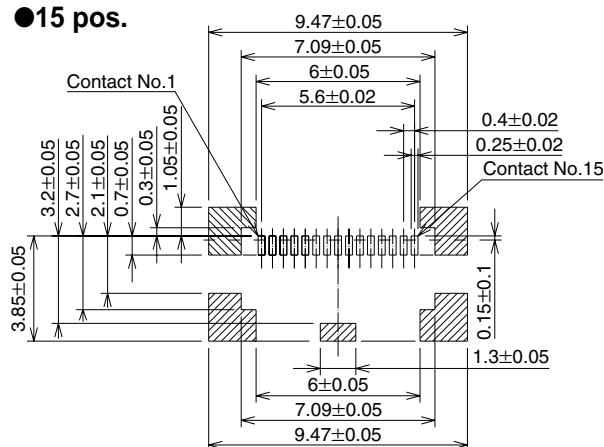

●25 pos.

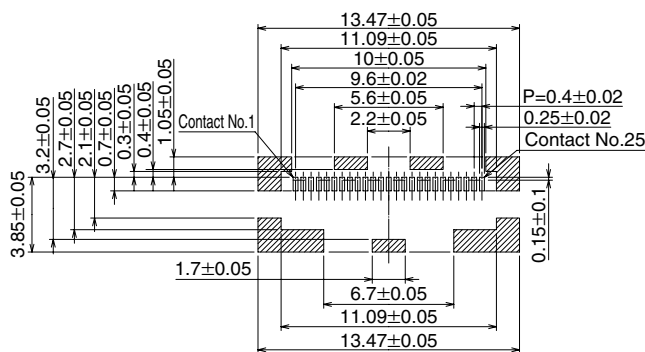

●30 pos.

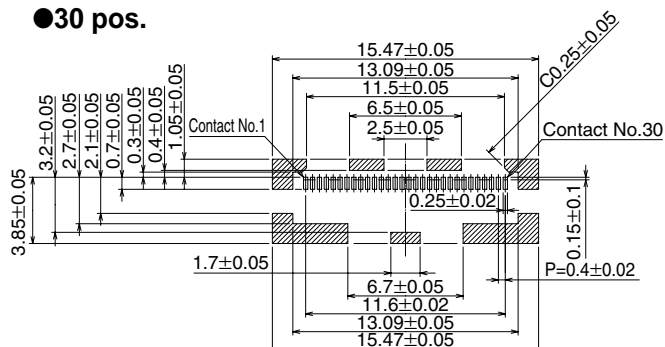

▨ Ground connecting areas

## Recommended PCB mounting patterns

### ● 40 pos.

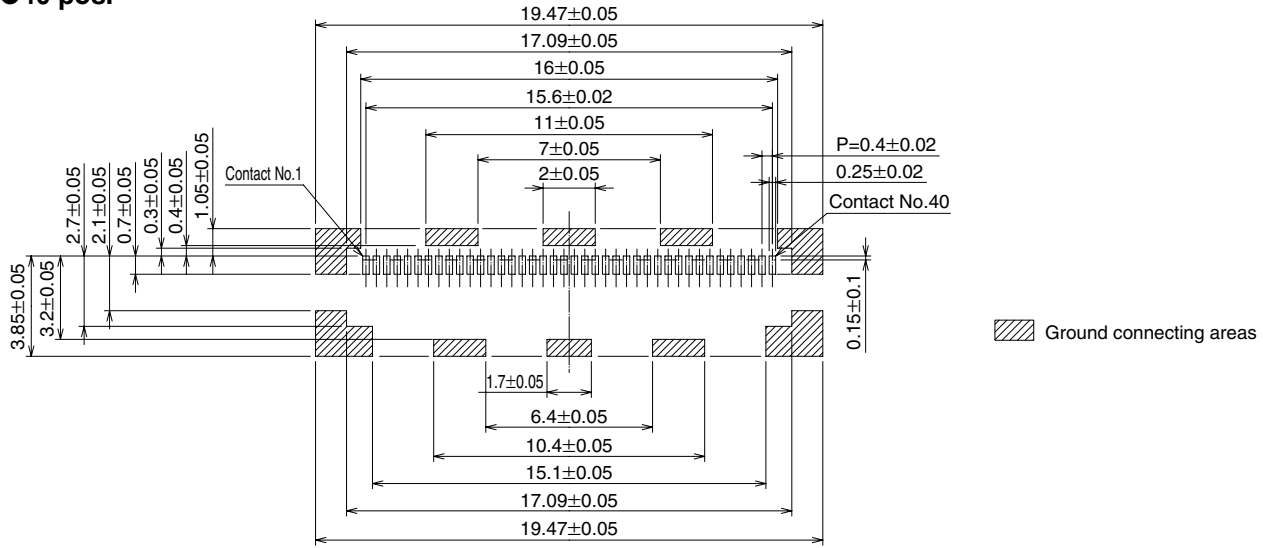

### ● 45 pos.

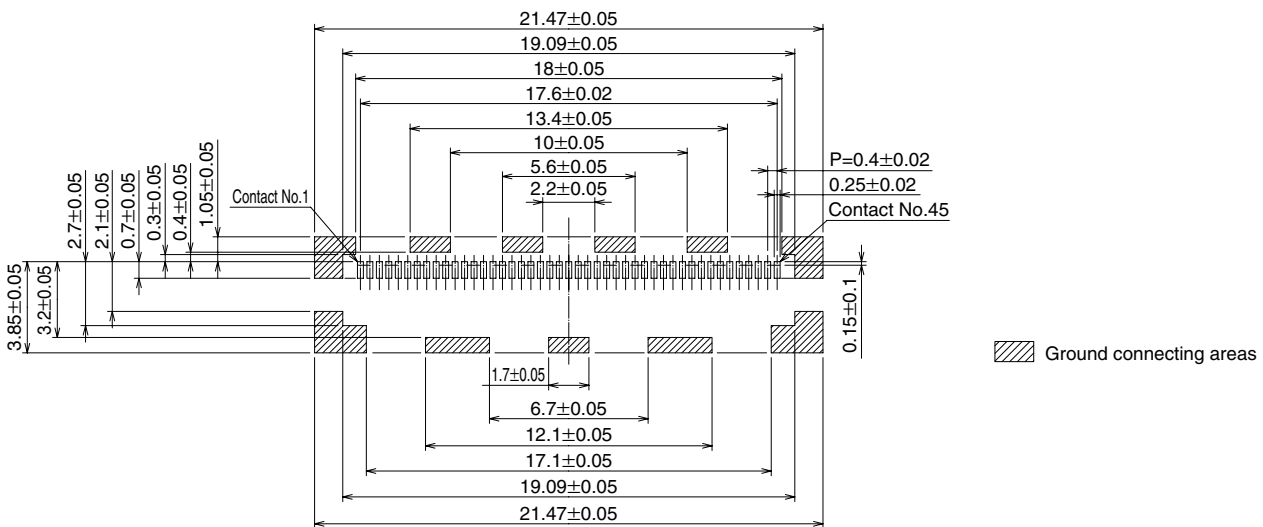

### ● 50 pos.

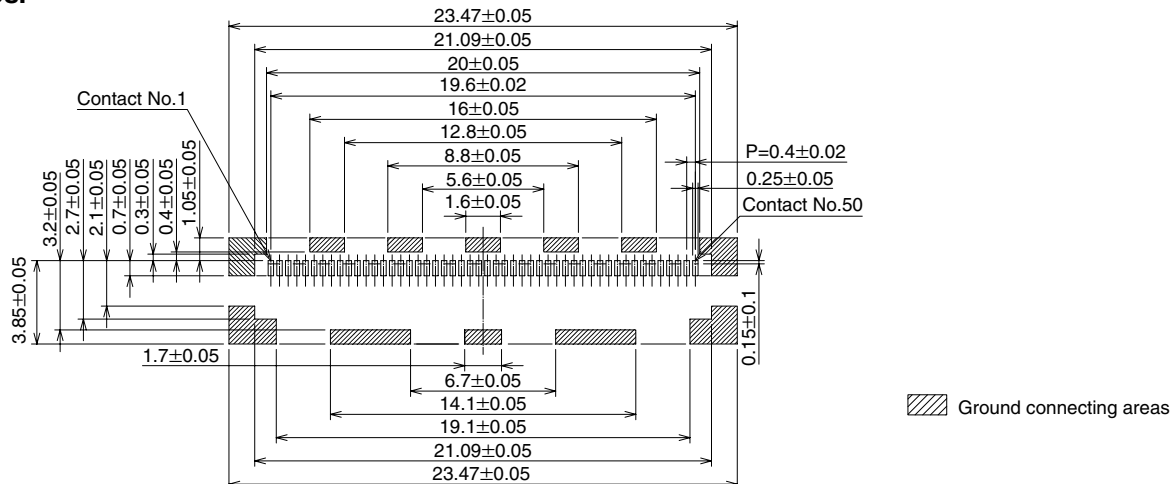

## ■ Receptacles - Space-saving

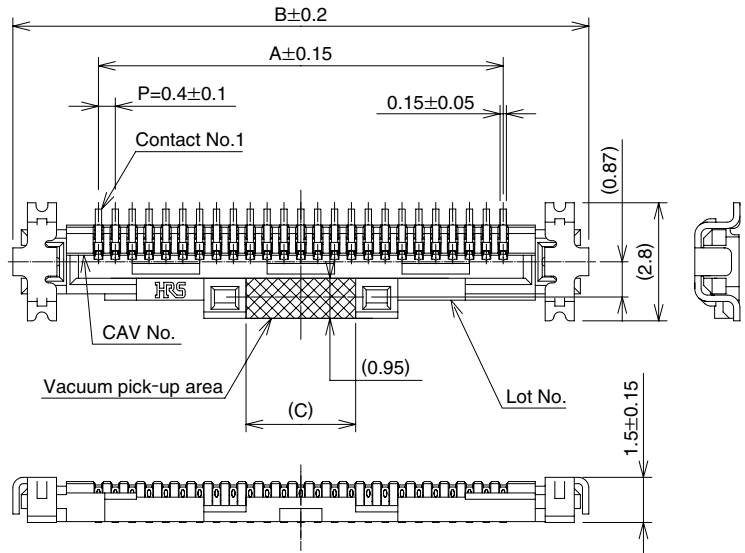
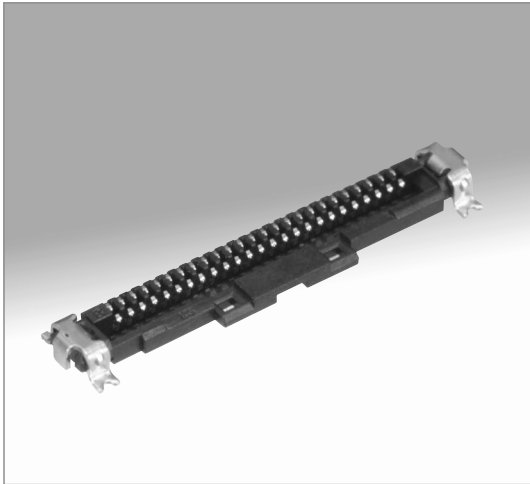

All dimensions: mm

Part Number	CL No.	Number of Contacts	A	B	C	D
DF36-15S-0.4V(**)	662-4031-1-***	15	5.6	9.66	2.6	8.28
DF36-20S-0.4V(**)	662-4039-3-***	20	7.6	11.66	2.6	10.28
DF36-25S-0.4V(**)	662-4005-1-***	25	9.6	13.66	2.6	12.28

[Specifications number] - \*\* , (\*\*)  
 (51) : Embossed tape packaging  
 (5,000 pieces per reel)

Note 1: Tape and reel packaging (5,000 pieces/reel).  
 Order by number of reels.

## ■ Recommended PCB mounting pattern

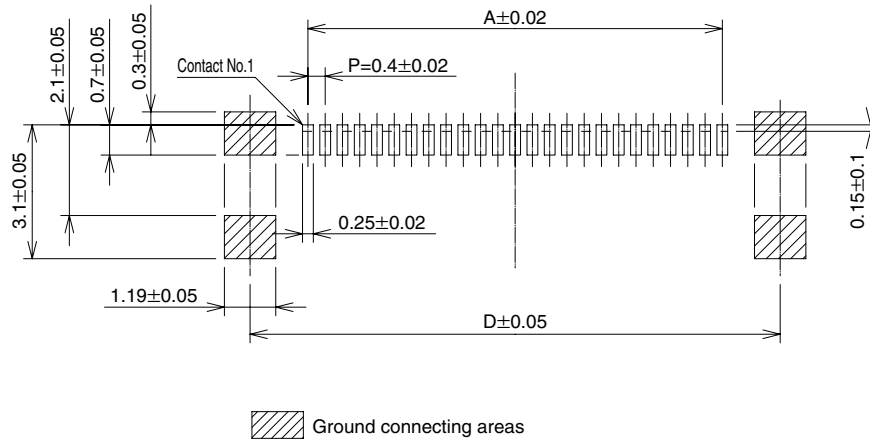

Ground connecting areas

## ■ Plug

● Separate metal cover required

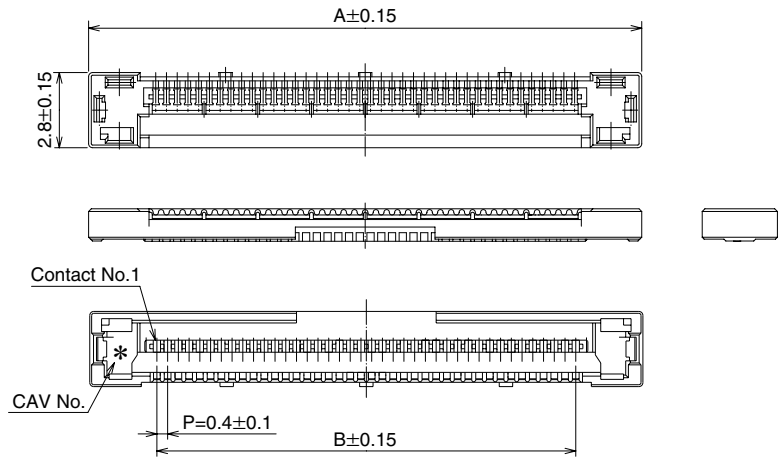
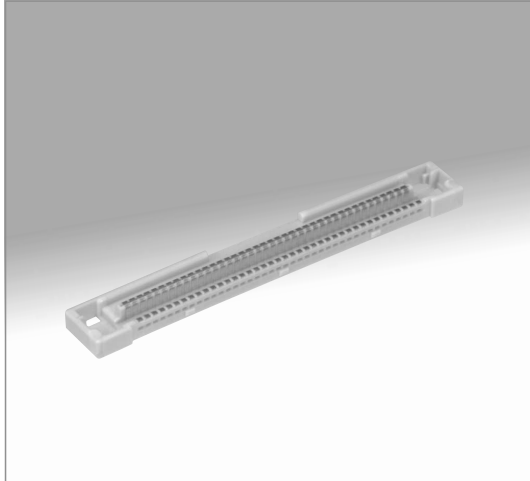

All dimensions: mm

Part Number	CL No.	Number of Contacts	A	B	C	D	Packing
DF36-15P-0.4SD(**)	662-4510-4-**	15	10.6	5.6	6.6	7.5	5,000 pcs./reel
DF36-20P-0.4SD(**)	662-4040-2-**	20	12.6	7.6	8.6	9.5	5,000 pcs./reel
DF36-25P-0.4SD(**)	662-4006-4-**	25	14.6	9.6	10.6	11.5	5,000 pcs./reel
DF36-30P-0.4SD(**)	662-4018-3-**	30	16.6	11.6	12.6	13.5	5,000 pcs./reel
DF36-40P-0.4SD(**)	662-4002-3-**	40	20.6	15.6	16.6	17.5	5,000 pcs./reel
DF36-45P-0.4SD(**)	662-4009-2-**	45	22.6	17.6	18.6	19.5	5,000 pcs./reel
DF36-50P-0.4SD(**)	662-4044-3-**	50	24.6	19.6	20.6	21.5	5,000 pcs./reel

Note 1: Tape and reel packaging(5,000 pieces / reel) order by number of reels.

Note 2: The metal cover is required for fine coaxial cable termination.

## ■ Recommended Fine Coaxial Cable Preparation

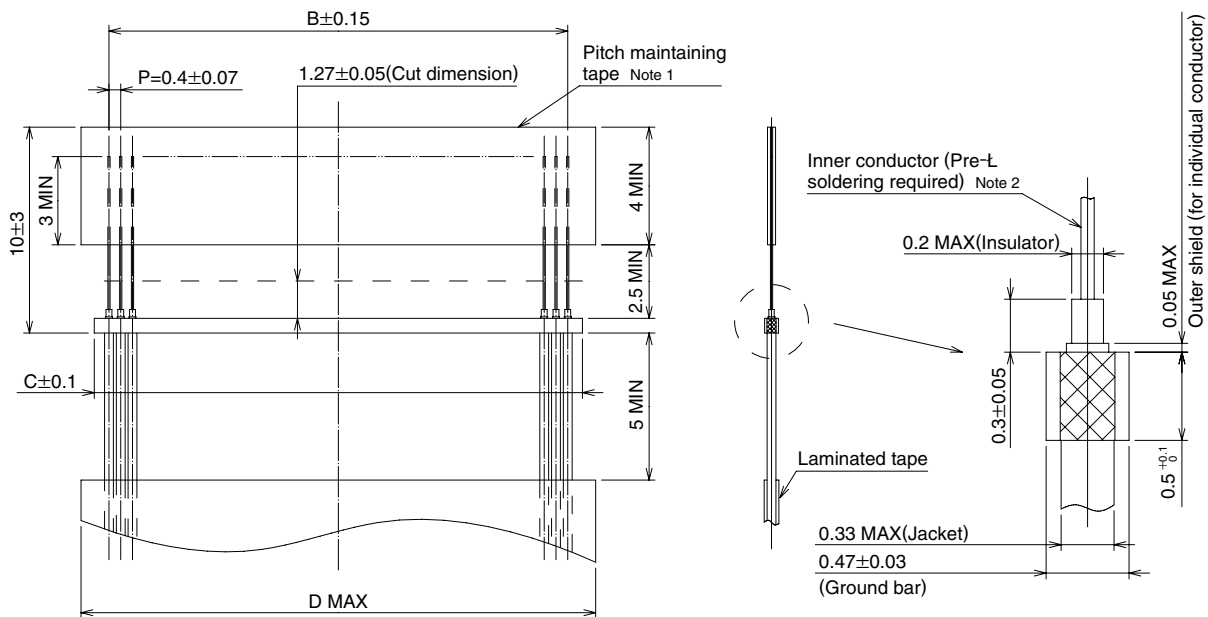

Note 1: The pitch maintaining tape can be left in place during the termination process. Use high quality tape.

Note 2: Contact Hirose for Termination Procedures.

## ■ Metal cover - Required for assembly and termination of the Plug

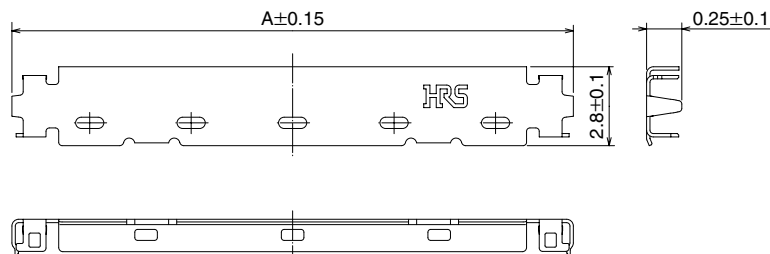
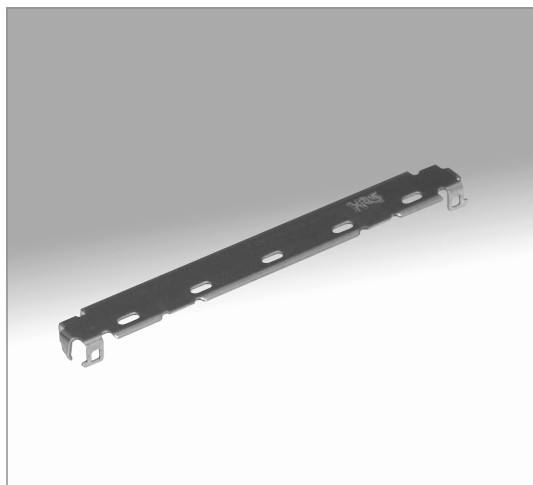

### [ Standard ]

All dimensions: mm

Part Number	Part Number	Plating	Number of Contacts	A
DF36A-15P-SHL	CL662-4511-7	Tin	15	9.92
DF36A-20P-SHL	CL662-4042-8		20	11.92
DF36A-25P-SHL	CL662-4007-7		25	13.92
DF36A-30P-SHL	CL662-4019-6		30	15.92
DF36A-40P-SHL	CL662-4013-0		40	19.92
DF36A-45P-SHL	CL662-4010-1		45	21.92
DF36A-50P-SHL	CL662-4045-6		50	23.92

Note 1: Tape and reel packaging (10,000 pieces/reel).  
 Order by number of reels.

### [ Space-saving ]

All dimensions: mm

Part Number	Part Number	Plating	Number of Contacts	A
DF36-15P-SHL	CL662-4026-1	Gold	15	9.92
DF36-20P-SHL	CL662-4041-5		20	11.92
DF36-25P-SHL	CL662-4012-7		25	13.92

Note 1: Tape and reel packaging (10,000 pieces/reel).  
 Order by number of reels.



## ■ Packaging Specification

### ● Embossed Carrier Tape Dimensions – Standard Receptacle

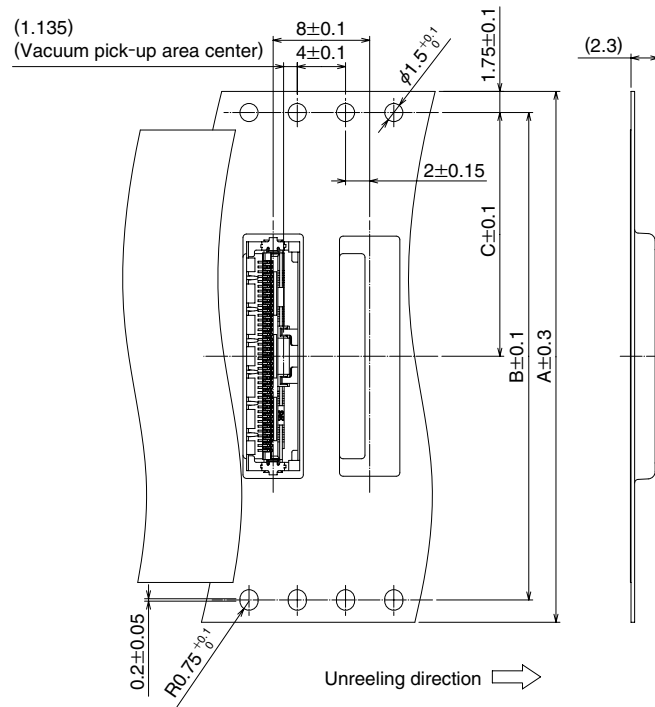

### ● Reel Dimensions

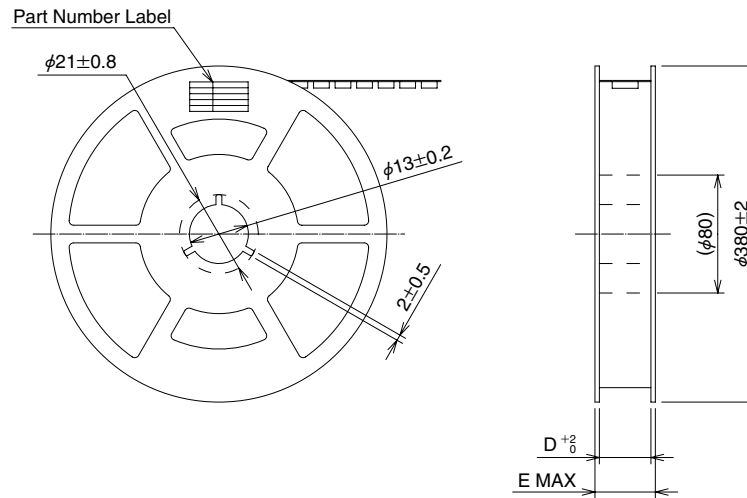

All dimensions: mm

Part Number	CL No.	Number of Contacts	A	B	C	D	E
DF36A-15S-0.4V(51)	662-4509-5-51	15	32	28.4	14.2	32.4	38.4
DF36A-20S-0.4V(51)	662-4037-8-51	20	32	28.4	14.2	32.4	38.4
DF36A-25S-0.4V(51)	662-4011-4-51	25	32	28.4	14.2	32.4	38.4
DF36A-30S-0.4V(51)	662-4017-0-51	30	32	28.4	14.2	32.4	38.4
DF36A-40S-0.4V(51)	662-4003-6-51	40	44	40.4	20.2	44.4	50.4
DF36A-45S-0.4V(51)	662-4008-0-51	45	44	40.4	20.2	44.4	50.4
DF36A-50S-0.4V(51)	662-4043-0-51	50	44	40.4	20.2	44.4	50.4

Note 1: Tape and reel packaging (4,000 pieces/reel).

## ■ Packaging Specification

### ● Embossed Carrier Tape Dimensions – Space saving Receptacle

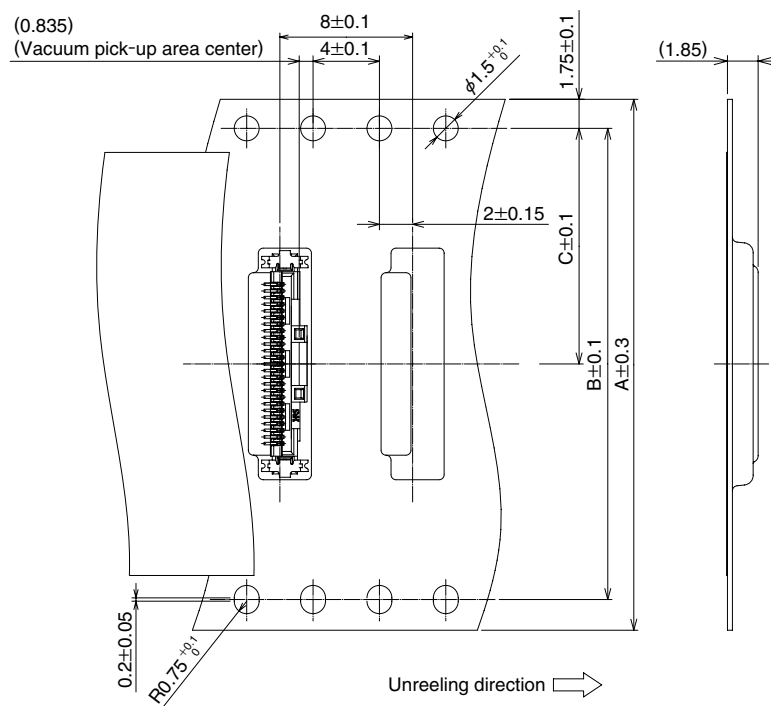

### ● Reel Dimensions

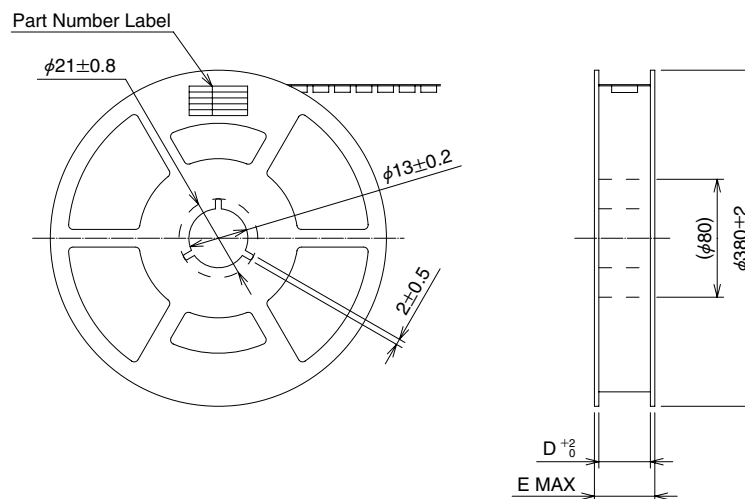

All dimensions: mm

Part Number	CL No.	Number of Contacts	A	B	C	D	E
DF36-15S-0.4V(51)	CL662-4031-1-51	15	32	28.4	14.2	32.4	38.4
DF36-20S-0.4V(51)	CL662-4039-3-51	20	32	28.4	14.2	32.4	38.4
DF36-25S-0.4V(51)	CL662-4005-1-51	25	32	28.4	14.2	32.4	38.4

Note 1: Tape and reel packaging (5,000 pieces/reel).

## ■ Packaging Specification

### ● Plug

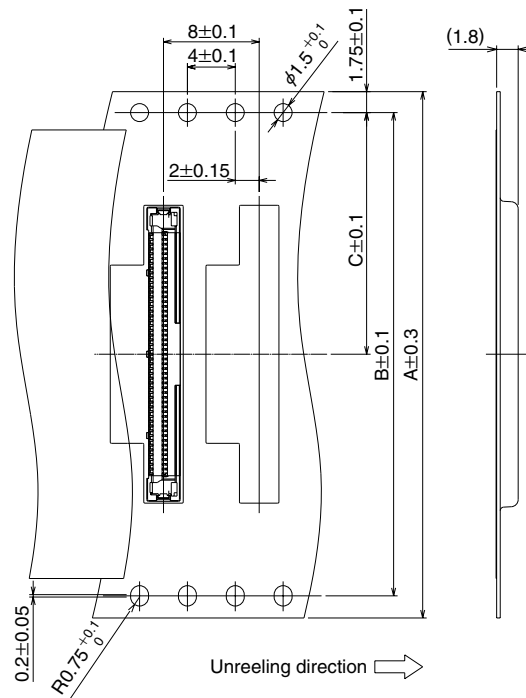

### ● Reel Dimensions

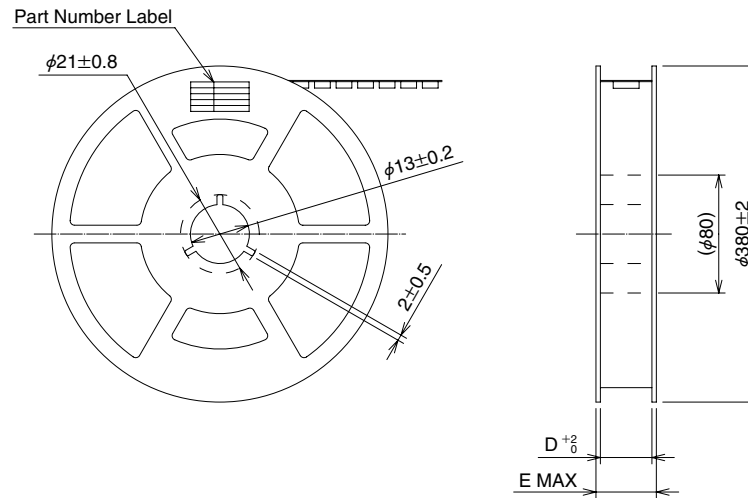

All dimensions: mm

Part Number	CL No.	Number of Contacts	A	B	C	D
DF36-15P-0.4SD(51)	662-4510-4-51	15	32	28.4	14.2	32.4
DF36-20P-0.4SD(51)	662-4040-2-51	20	32	28.4	14.2	32.4
DF36-25P-0.4SD(51)	662-4006-4-51	25	32	28.4	14.2	32.4
DF36-30P-0.4SD(51)	662-4006-4-51	30	32	28.4	14.2	32.4
DF36-40P-0.4SD(51)	662-4002-3-51	40	44	40.4	20.2	44.4
DF36-45P-0.4SD(51)	662-4009-2-51	45	44	40.4	20.2	44.4
DF36-50P-0.4SD(51)	662-4044-3-51	50	44	40.4	20.2	44.4

Note 1: Tape and reel packaging (5,000 pieces/reel).

## ■ Extraction tool

For details about the extraction tool, please contact your Hirose sales representative.

## ■ Usage Recommendations

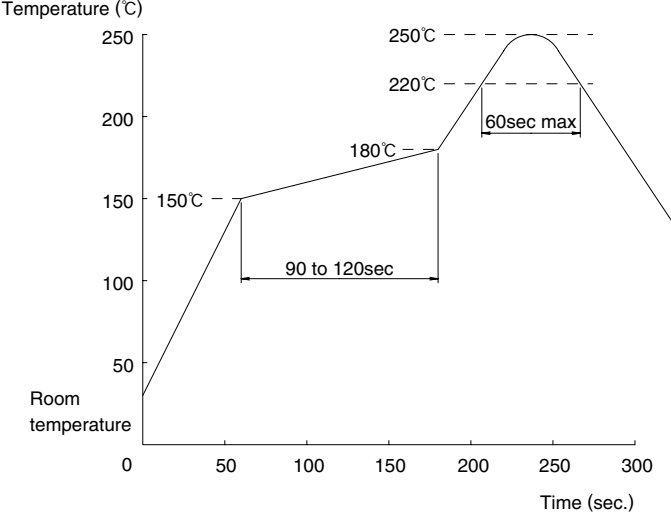
<p>1.Recommended temperature profile</p>	 <p>Solder composition: Paste, 96.5%Sn/3.0%Ag/0.5%Cu</p> <p>Note 1: Up to 2 cycles of Reflow soldering are possible under the same conditions, provided that there is a return to normal temperature between the first and second cycle.</p> <p>Note 2: The temperature profile indicates the board surface temperature at the point of contacts with the connector terminals.</p>
<p>2.Recommended manual soldering</p>	<p>Manual soldering: 350°C for 3 seconds                  Do NOT use flux compound when manual soldering.</p>
<p>3.Recommended screen thickness and open area ratio (Pattern area ratio)</p>	<p>Standard Thickness: 0.1 mm                  Open area ratios: Lead terminal: 90%                                            Ground terminal: 100%                  Space-saving Thickness: 0.1 mm                  Open area ratios: Lead terminal: 90%                                            Ground terminal: 90%</p>
<p>4.Board warpage</p>	<p>Maximum of 0.02 mm at the connector center, with both ends of the connector as reference points.</p>
<p>5.Cleaning conditions</p>	<p>Refer to "Nylon Connector Use Handbook".</p>

## ■ Precautions

### Precautions

· Mating / un-mating

#### [ Standard ]

Mate the plug with the receptacle by pressing straight against the entire plug surface. Do NOT mate the plug while holding by the terminated cable.

Use a dedicated extraction tool to un-mate the plug.

Insert the tool under either end of the plug (clearance) and pull straight up as illustrated below.

Please refrain from removing by holding the electrical cable, otherwise this may result in cable disconnection, connector breakage and so on.

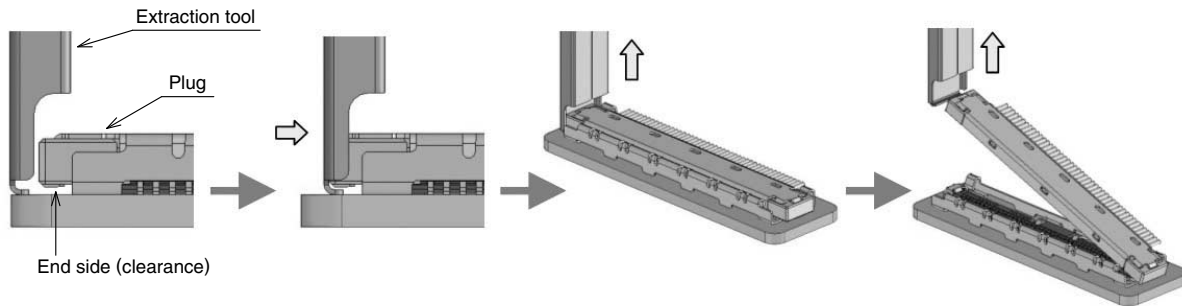

#### [ Space-saving ]

Mate the plug with the receptacle by pressing straight against the entire plug surface, the same as the standard. Use a dedicated extraction tool to un-mate the plug.

Insert the tool under the plug at the front side (clearance) and pull straight up, as illustrated below.

Do NOT mate / un-mate the connectors when receptacle is not mounted on the board.

Please refrain from removing by holding the electrical cable, otherwise this may result in cable disconnection, connector breakage and so on.

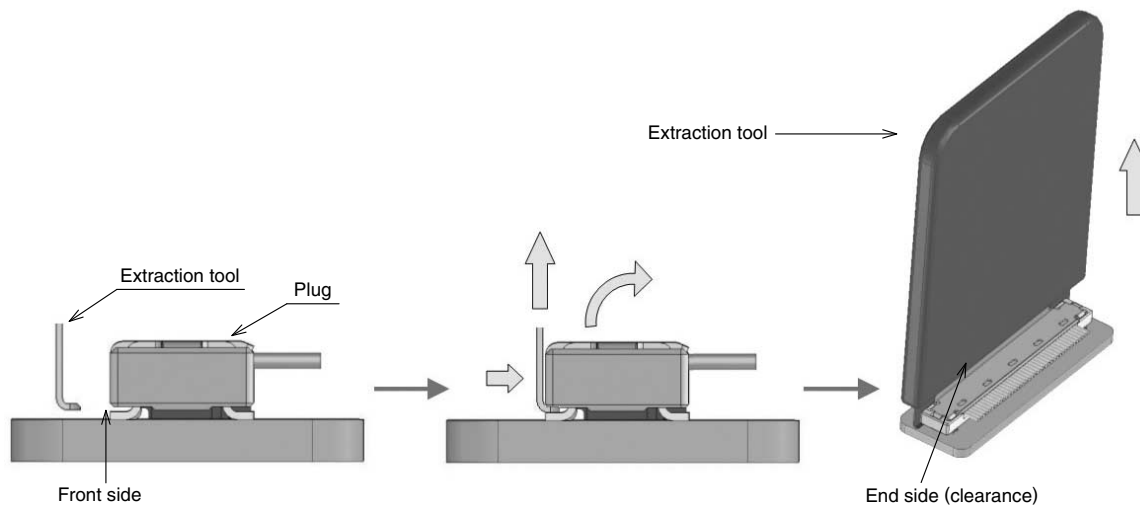

- Do not mate / un-mate the connectors when receptacle is not mounted on the board.
- In the manual soldering process, don't carry out the flux coating which will cause a flux blister on the connector.
- Different production lots may exhibit different shades of the insulator materials. No affect on form, fit or function of the connectors.
- Excessive scoop insertion or extraction may result in damage.