

THIS DRAWING IS UNPUBLISHED
 ALL RIGHTS RESERVED

REV	DATE	DESCRIPTION	BY	CHK	APP
GP 00					
AA		REVISED PER EDD-11-004835	11MR11	RK	HMR

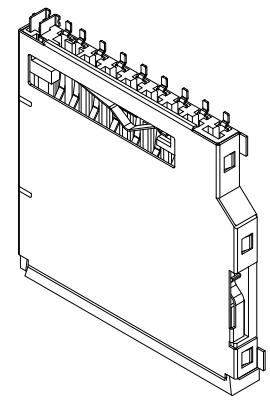

- ⚠ MATERIAL:
HOUSING: THERMOPLASTIC, WITH 30% GLASS FIBER FILLED, UL 94V-0 RATED, COLOR: IVORY.
CONTACTS: PHOSPHOR BRONZE, THICKNESS=0.20mm.
SHIELD: STEEL ALLOY, THICKNESS=0.20mm.
- ⚠ FINISH:
CONTACT: 30μm MIN GOLD PLATED ON CONTACT AREA.
80μm MIN MATTE TIN PLATED ON SOLDERTAILS.
50μm MIN NICKEL UNDERPLATE ALL OVER.
SHIELD: GOLD FLASH ON SOLDERING AREA. 30μm MIN NICKEL UNDERPLATED ALL OVER.
- ⚠ FINISH:
CONTACT: 10μm MIN GOLD PLATED ON CONTACT AREA.
80μm MIN MATTE TIN PLATED ON SOLDERTAILS.
50μm MIN NICKEL UNDERPLATE ALL OVER.
SHIELD: GOLD FLASH ON SOLDERING AREA. 30μm MIN NICKEL UNDERPLATED ALL OVER.
- 4. SWITCH: NORMALLY OPEN.
- 5. REFLOW SOLDER CAPABLE TO 260°C PER TE CONNECTIVITY SPEC 109-201, CONDITION B.

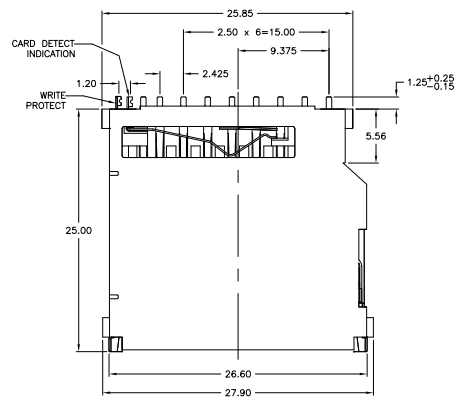
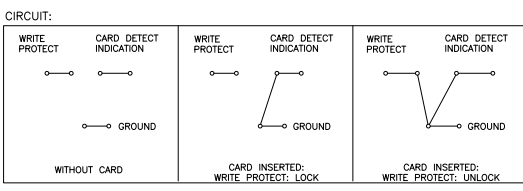
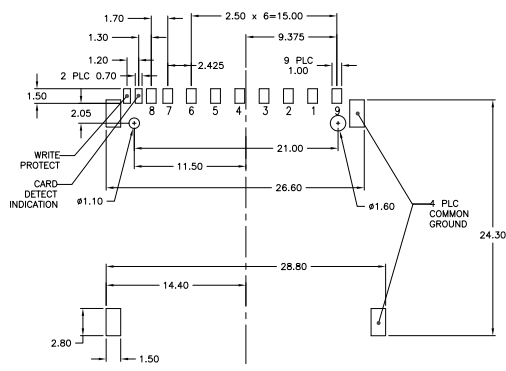
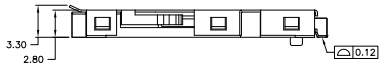
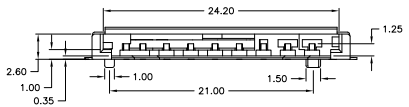

⚠	REEL	2041021-4
⚠	TRAY	2041021-3
⚠	REEL	2041021-2
⚠	TRAY	2041021-1
⚠	PACKAGING	PART NUMBER

RECOMMENDED PCB LAYOUT
 TOLERANCES: ±0.05mm

THIS DRAWING IS A CONTROLLED DOCUMENT.

REVISION	DATE	DESCRIPTION	BY	CHK	APP
1					

SECURE DIGITAL CARD CONNECTOR

DATE: 10/07/99 DRAWING NO: 2041021

CUSTOMER DRAWING

THIS DRAWING IS UNPUBLISHED
 ALL RIGHTS RESERVED

REV	DATE	DESCRIPTION	BY	CHK	APP
GP 00		SEE SHEET 1			

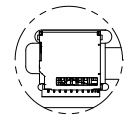
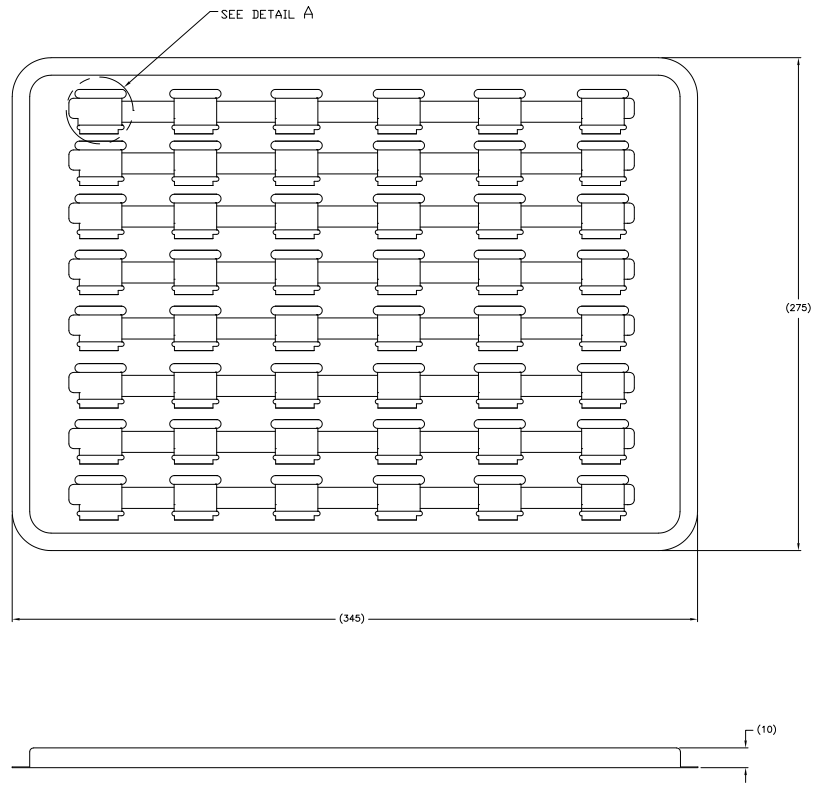

DETAIL A
 PART ORIENTATION
 SHOWN FOR REFERENCE

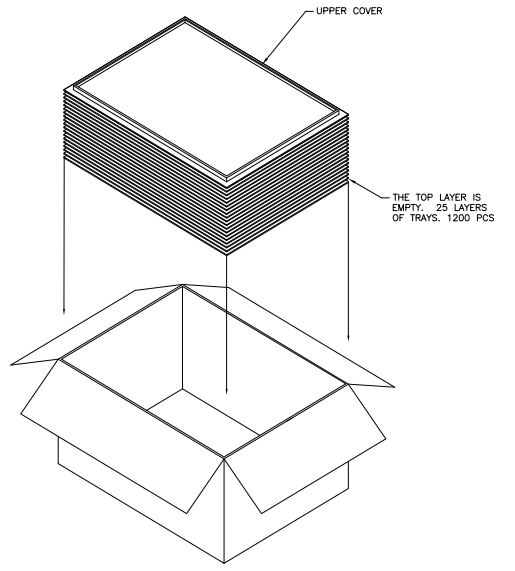

TRAY PACKAGING FOR
 2041021-1 AND 2041021-3
 48 PIECES PER TRAY.
 -NTS-

THIS DRAWING IS A CONTROLLED DOCUMENT.		DR. J. MCMASTER	DESIGN	TE Connectivity	
DRAWING NO. 100779		DR. J. GOSWAMI	REVISION	SECURE DIGITAL CARD CONNECTOR	
DATE	SIZE	SCALE	DRAWING NO.	REVISED TO	
A1	00779	Q=2041021			
CUSTOMER DRAWING			DATE	SHEET	OF
			6.1	2	3
					A4

488 (2/11)

THIS DRAWING IS UNPUBLISHED
 ALL RIGHTS RESERVED

REV	DATE	DESCRIPTION	BY	APP
00		SEE SHEET 1		

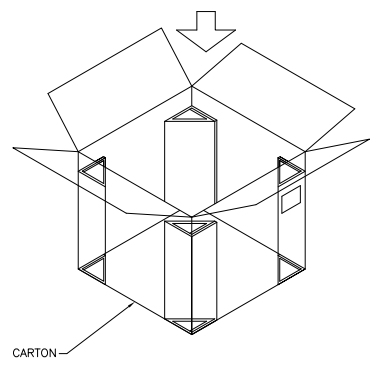
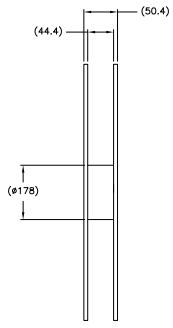
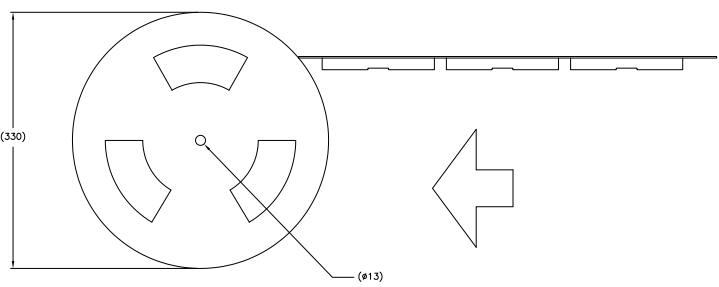
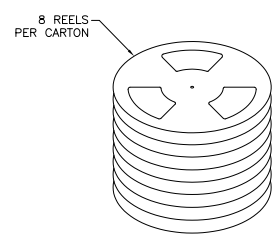
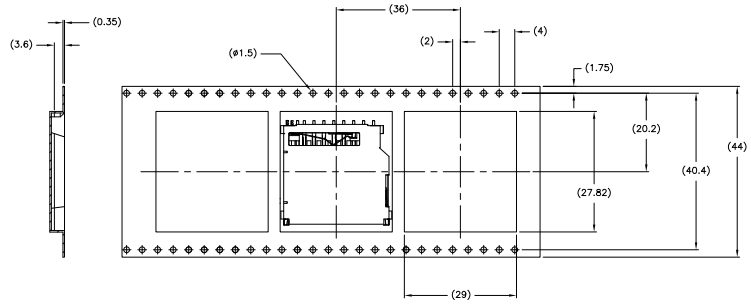

TAPE AND REEL PACKAGING FOR
 2041021-2 AND 2041021-4
 300 PIECES PER REEL
 -NTS-

THIS DRAWING IS A CONTROLLED DOCUMENT.		REV. 00	DATE	DESCRIPTION	BY	APP
DRAWING NO. 00779		REV. 00	DATE	DESCRIPTION	BY	APP
CUSTOMER DRAWING		REV. 00	DATE	DESCRIPTION	BY	APP
DRAWING NO. 00779		REV. 00	DATE	DESCRIPTION	BY	APP
CUSTOMER DRAWING		REV. 00	DATE	DESCRIPTION	BY	APP