

HC-M-04-ST-KOAX-50

Order No.: 1676815



<http://eshop.phoenixcontact.de/phoenix/treeViewClick.do?UID=1676815>

Coaxial contact, for the HC-M-4-MOD-BU module, 50 Ohm

Commercial data	
GTIN (EAN)	
sales group	D045
Pack	10 pcs.
Customs tariff	85366910
Catalog page information	Page 461 (PC-2009)

Product notes

WEEE/RoHS-compliant since:
07/03/2006



<http://www.download.phoenixcontact.com>
Please note that the data given here has been taken from the online catalog. For comprehensive information and data, please refer to the user documentation. The General Terms and Conditions of Use apply to Internet downloads.

Technical data

Electrical characteristics	
Note	Cables that can be used for the coaxial contact: RG174/U, RG188A/U, RG316/U
Rated voltage	50 V AC
Rated current	1.5 A
Volume resistance	≤ 10 mΩ (Phase conductors)
Insulation resistance	10 GΩ

Wave impedance	50 Ω
----------------	------

Mechanical characteristics

Conductor cross section AWG/kcmil max.	14
Conductor cross section AWG/kcmil min.	26
Conductor cross section stranded max.	2.5 mm ²
Conductor cross section stranded min.	0.14 mm ²
Insertion/withdrawal cycles	≥ 500

General characteristics

Connection in acc. with standard	IEC / EN
----------------------------------	----------

Material data

Contact material	Copper alloy
Contact surface material	Au

Certificates / Approvals



Certification GOST, UL

Accessories

Item	Designation	Description
Tools		
1206023	CRIMPFOX-HCM-KOAX	Crimping pliers, for coaxial, male and female contacts acc. to DIN 41626, contacts HC-M-04-ST-KOAX-... and HC-M-04-BU-KOAX-... 50 and 75 Ohms respectively
1676747	HC-M4-KOAX-EWZ	Contact removal tool for coaxial contacts

Diagrams/Drawings

Schematic diagram

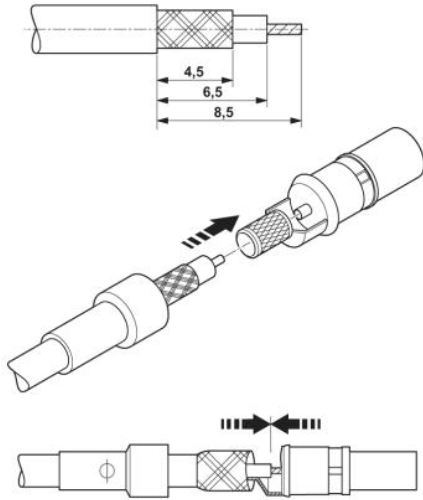

Assembly instructions:

Strip off 8.5 mm of the cable and push the sleeve onto the cable. Then solder the wire with the coaxial contact and place the braided shield above the ridges of the contact. Slide the sleeve over the braided shield and crimp the cable along the narrow contact collar.

Address

PHOENIX CONTACT Deutschland GmbH
Flachsmarktstr. 8
32825 Blomberg, Germany
Phone +49 5235 3 12000
Fax +49 5235 3 41200
<http://www.phoenixcontact.de>



© 2010 Phoenix Contact
Technical modifications reserved;