



Features

- Radial Leaded Devices
- Cured, flame retardant epoxy polymer insulating material meets UL 94V-0 requirements
- RoHS compliant*
- Lead free
- Agency recognition:   

Applications

- Almost anywhere there is a load to be protected with a voltage supply of up to 90 V, including:
- Broadband cable power passing taps
 - Set-top boxes

MF-R/90 Series - PTC Resettable Fuses

Electrical Characteristics

Model	V max. Volts	I max. Amps	Ihold	Itrip	Initial Resistance Values		One Hour Post-Trip Resistance Standard Trip	Maximum Time To Trip		Nominal Tripped Power Dissipation
			Amps at 23 °C	Amps at 23 °C	Ohms at 23 °C		Ohms at 23 °C	Amps at 23 °C	Seconds at 23 °C	Watts at 23 °C
			Hold	Trip	Min.	Max.	Max.			Typ.
MF-R055/90	90	10	0.55	1.1	0.45	0.9	2.0	1.6	60	2.0
MF-R055/90U	90	10	0.55	1.1	0.45	0.9	2.0	1.6	28	2.0
MF-R075/90	90	10	0.75	1.5	0.37	0.75	1.65	2.0	60	2.5

"U" suffix indicates product without insulation coating.

Environmental Characteristics

Operating/Storage Temperature	-40 °C to +85 °C
Maximum Device Surface Temperature	
in Tripped State	125 °C
Passive Aging	+85 °C, 1000 hours±5 % typical resistance change
Humidity Aging	+85°C, 85% R.H. 1000 hours.....±5 % typical resistance change
Thermal Shock	+125 °C to -55 °C, 10 times.....±10 % typical resistance change
Solvent Resistance	MIL-STD-202, Method 215No change
Vibration	MIL-STD-883C, Method 2007.1,No change
Condition A	

Test Procedures And Requirements For Model MF-R/90 Series

Test	Test Conditions	Accept/Reject Criteria
Visual/Mech.	Verify dimensions and materials.....	Per MF physical description
Resistance	In still air @ 23 °C	$R_{min} \leq R \leq R_{max}$
Time to Trip	At specified current, V_{max} , 23 °C	$T \leq \text{max. time to trip (seconds)}$
Hold Current	30 min. at Ihold.....	No trip
Trip Cycle Life	V_{max} , I_{max} , 100 cycles	No arcing or burning
Trip Endurance.....	V_{max} , 48 hours	No arcing or burning

UL File NumberE 174545S
 CSA File NumberCA 110338
 TÜV File NumberR2057213

Thermal Derating Chart - Ihold / Itrip (Amps)

Model	Ambient Operating Temperature								
	-40 °C	-20 °C	0 °C	23 °C	40 °C	50 °C	60 °C	70 °C	85 °C
MF-R055/90	0.85 / 1.7	0.75 / 1.5	0.65 / 1.3	0.55 / 1.1	0.45 / 0.9	0.4 / 0.8	0.35 / 0.7	0.3 / 0.6	0.22 / 0.44
MF-R055/90U	0.85 / 1.7	0.75 / 1.5	0.65 / 1.3	0.55 / 1.1	0.45 / 0.9	0.4 / 0.8	0.35 / 0.7	0.3 / 0.6	0.22 / 0.44
MF-R075/90	1.15 / 2.3	1.0 / 2.0	0.9 / 1.8	0.75 / 1.5	0.61 / 1.22	0.55 / 1.1	0.48 / 0.96	0.41 / 0.82	0.30 / 0.6

*RoHS Directive 2002/95/EC Jan 27 2003 including Annex
 Specifications are subject to change without notice.
 Customers should verify actual device performance in their specific applications.

Additional Features

- Bulk packaging, tape and reel and Ammo-Pak available on most models
- Patents pending

MF-R/90 Series - PTC Resettable Fuses

BOURNS®

Product Dimensions

Model	A Max.	B Max.	C (Pitch) Nom.	D Min.	E Max.	Physical Characteristics		
						Style	Lead Dia.	Material
MF-R055/90	$\frac{10.9}{(0.43)}$	$\frac{16.7}{(0.65)}$	$\frac{5.1 \pm 0.7}{(0.201 \pm 0.028)}$	$\frac{6.3}{(0.248)}$	$\frac{3.6}{(0.142)}$	1	$\frac{0.81}{(0.032)}$	Sn/Cu
MF-R055/90U	$\frac{10.3}{(0.4)}$	$\frac{16.7}{(0.65)}$	$\frac{5.1 \pm 0.7}{(0.201 \pm 0.028)}$	$\frac{6.3}{(0.248)}$	$\frac{3.0}{(0.118)}$	1	$\frac{0.81}{(0.032)}$	Sn/Cu
MF-R075/90	$\frac{11.9}{(0.47)}$	$\frac{15.5}{(0.61)}$	$\frac{5.1 \pm 0.7}{(0.201 \pm 0.028)}$	$\frac{6.3}{(0.248)}$	$\frac{3.6}{(0.142)}$	1	$\frac{0.81}{(0.032)}$	Sn/Cu

Packaging options:

BULK: 500 pcs. per bag. TAPE & REEL: 1500 pcs. per reel. AMMO-PACK: 1000 pcs. per pack

DIMENSIONS = $\frac{\text{MM}}{(\text{INCHES})}$

Style 1

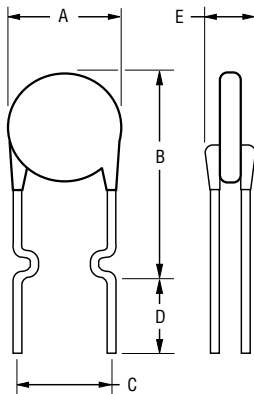

Also available with straight leads.

Typical Part Marking

Represents total content. Layout may vary.

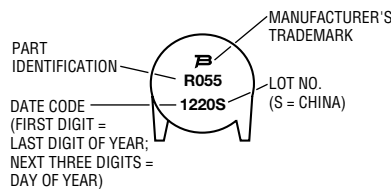

How to Order

MF - R 055/90 U - 0

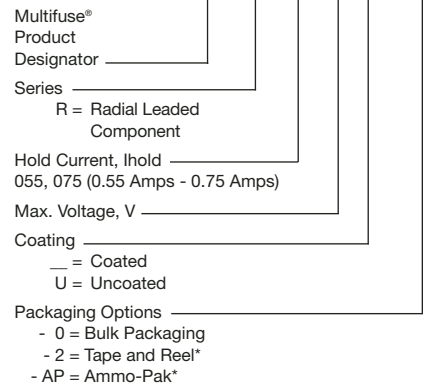

*Packaged per EIA486-B

Typical Time to Trip at 23 °C



MF-R/90, REV. E, 02/08

Specifications are subject to change without notice. Customers should verify actual device performance in their specific applications.

**MF-R, MF-R/72, MF-R/90, MF-R/600, MF-RX, MF-RX/72 & MF-RX/250 Series
Tape and Reel Specifications**

BOURNS®

Devices taped using EIA468-B/IEC286-2 standards. See table below and Figures 1 and 2 for details.

Dimension Description	IEC Mark	EIA Mark	Dimensions	
			Dimensions	Tolerance
Carrier tape width	W	W	$\frac{18}{(.709)}$	$\frac{-0.5/+1.0}{(-0.02/+0.039)}$
Hold down tape width:	W_0	W_4	$\frac{11}{(.433)}$	min.
Hold down tape			No protrusion	
Top distance between tape edges	W_2	W_6	$\frac{3}{(.118)}$	max.
Sprocket hole position	W_1	W_5	$\frac{9}{(.354)}$	$\frac{-0.5/+0.75}{(-0.02/+0.03)}$
Sprocket hole diameter	D_0	D_0	$\frac{4}{(.157)}$	$\frac{\pm 0.2}{(\pm .0078)}$
Abscissa to plane (straight lead)	H	H	$\frac{18.5}{(.728)}$	$\frac{\pm 3.0}{(\pm .118)}$
Abscissa to plane (kinked lead)	H_0	H_0	$\frac{16}{(.63)}$	$\frac{\pm 0.5}{(\pm .02)}$
Abscissa to top (straight lead)	H_1	H_1	$\frac{38.0}{(1.496)}$	max.
Abscissa to top (kinked lead)	H_1	H_1	$\frac{32.2}{(1.268)}$	max.
Overall width w/lead protrusion (straight lead)		C_1	$\frac{55.0}{(2.165)}$	max.
Overall width w/lead protrusion (kinked lead)		C_1	$\frac{43.2}{(1.7)}$	max.
Overall width w/o lead protrusion (straight lead)		C_2	$\frac{54.0}{(2.126)}$	max.
Overall width w/o lead protrusion (kinked lead)		C_2	$\frac{42.5}{(1.673)}$	max.
Lead protrusion	I_1	L_1	$\frac{1.0}{(.039)}$	max.
Protrusion of cutout	L	L	$\frac{11}{(.433)}$	max.
Protrusion beyond hold tape	I_2	I_2	Not specified	
Sprocket hole pitch	P_0	P_0	$\frac{12.7}{(0.5)}$	$\frac{\pm 0.3}{(\pm .012)}$
Pitch tolerance			20 consecutive	$\frac{\pm 1}{(\pm .039)}$
Device pitch: MF-R005-MF-R160, MF-R/90, MF-RX110/72-MF-RX185/72, MF-R/72			$\frac{12.7}{(0.5)}$	$\frac{\pm 0.3}{(\pm .012)}$
Device pitch: MF-R185-MF-R400, MF-RX110-MF-RX375 MF-R/600, MF-RX250/72-MF-RX375/72			$\frac{25.4}{(1.0)}$	$\frac{\pm 0.6}{(\pm .024)}$
Tape thickness	t	t	$\frac{0.9}{(.035)}$	max.
Tape thickness with splice: MF-R010-MF-R160, MF-R/72, MF-RX110/72-MF-RX185/72,		t_1	$\frac{1.5}{(.059)}$	max.
Tape thickness with splice: MF-R250-MF-R1100 MF-RX110-MF-RX375, MF-R/90, MF-RX250/72-MF-RX375/72		t_1	$\frac{2.3}{(.091)}$	max.
Splice sprocket hole alignment			0	$\frac{\pm 0.3}{(\pm .012)}$ ± 1.0 $(\pm .039)$
Body lateral deviation	Δh	Δh	0	$\frac{\pm 1.3}{(\pm .051)}$
Body tape plane deviation	Δp	Δp	0	$\frac{\pm 0.2}{(\pm .008)}$
Lead spacing	F	F	$\frac{5.08}{(0.2)}$	$\frac{\pm 0.2}{(\pm .008)}$
Reel width	w	W_2	$\frac{56}{(2.205)}$	max.
Reel diameter	d	a	$\frac{370}{(14.57)}$	max.
Space between flanges less device	W_1	h	$\frac{4.75}{(.187)}$	$\frac{\pm 3.25}{(\pm .128)}$

Specifications are subject to change without notice.

Customers should verify actual device performance in their specific applications.

DIMENSIONS = $\frac{\text{MM}}{\text{(INCHES)}}$

**MF-R, MF-R/72, MF-R/90, MF-R/600, MF-RX, MF-RX/72 & MF-RX/250 Series
Tape and Reel Specifications**

BOURNS®

Dimension Description	IEC Mark	EIA Mark	Dimensions	
			Dimensions	Tolerance
Arbor hole diameter	<i>f</i>	<i>c</i>	$\frac{26}{(1.024)}$	$\frac{\pm 12.0}{(\pm .472)}$
Core diameter: MF-R, MF-RX, MF-R/90	<i>h</i>	<i>n</i>	$\frac{80}{(3.15)}$	max.
Core diameter: MF-RX/250, MF-R/600	<i>h</i>	<i>n</i>	$\frac{91}{(3.58)}$	max.
Box: MF-R, MF-RX, MF-R/90			$\frac{56}{(2.2)}$ $\frac{372}{(14.6)}$ $\frac{372}{(14.6)}$	max.
Box: MF-RX/250			$\frac{67}{(2.64)}$ $\frac{372}{(14.6)}$ $\frac{362}{(14.25)}$	max.
Box: MF-R/600			$\frac{64}{(2.52)}$ $\frac{372}{(14.6)}$ $\frac{362}{(14.25)}$	max.
Consecutive missing places: MF-R, MF-RX, MF-R/90			3	max.
Consecutive missing places: MF-RX/250, MF-R/600			none	
Empty places per reel: MF-R, MF-RX, MF-R/90			Not specified	
Empty places per reel: MF-RX/250, MF-R/600			0.1 %	

Taped Component Dimensions - Figure 1

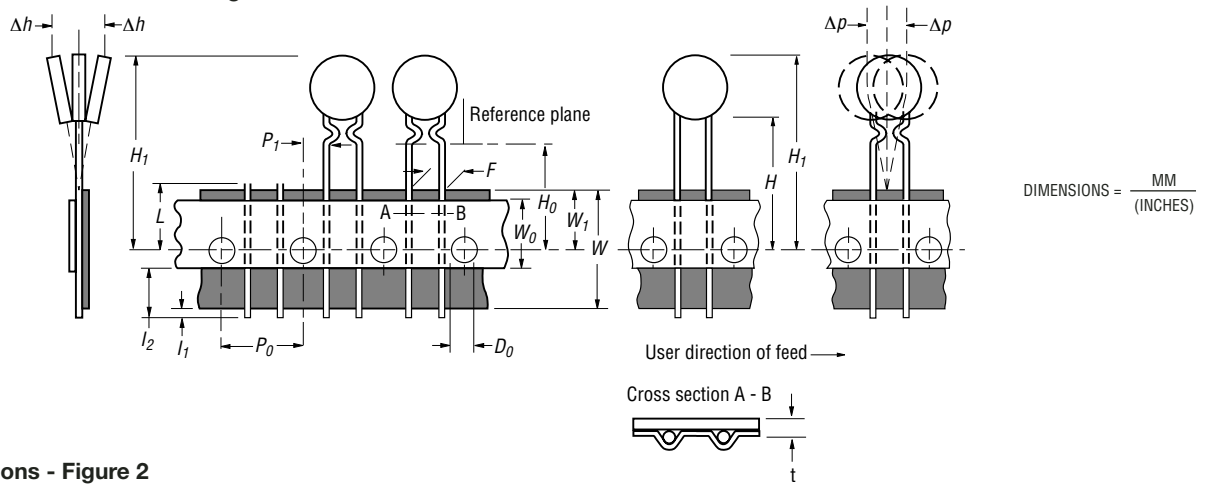

Reel Dimensions - Figure 2

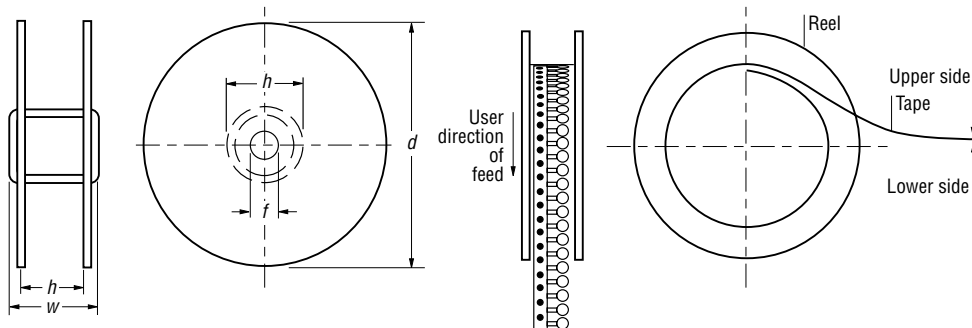

Specifications are subject to change without notice.
Customers should verify actual device performance in their specific applications.