

7 6 5 4 3 2 1

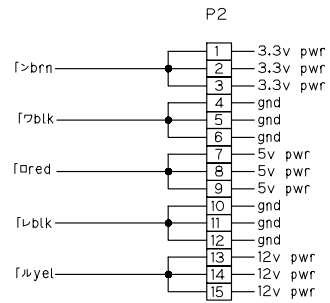
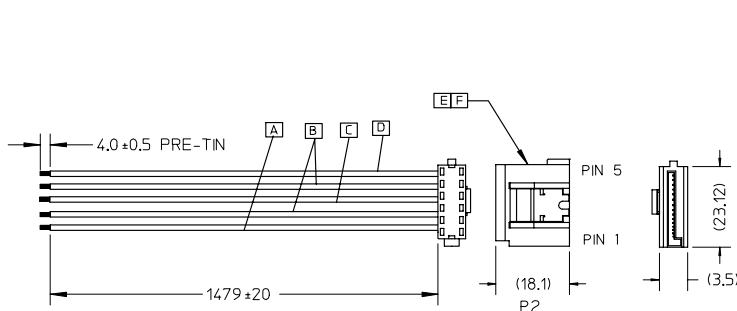

NOTE: 1. ELECTRIC PERFORMANCE:  
 DIELECTRIC STRENGTH: 500 V DC.  
 INSULATION RESISTANCE :100 MOHS MIN.  
 CONDUCTIVE RESISTANCE :2 OHMS MAX.  
 2. S-ATA HOUSING:  
 PLOYESTER(PBT), UL94V-0(BLACK)

|             |             |                             |
|-------------|-------------|-----------------------------|
| 68561-0023  | 679260002   | 30u' Gold - plated terminal |
| 68561-0022  | 679260001   | Gold flash terminal         |
| MATERIAL NO | S-ATA CONN. | DESCRIPTION                 |

|      |                          |     |       |
|------|--------------------------|-----|-------|
| F    | COVER 679260040          | 1   |       |
| E    | S-ATA CONN. : SEE TABLE  | 1   |       |
| D    | UL1007 #18 BRN 887711305 | 1   | 1485  |
| C    | UL1007 #18 RED 887711301 | 1   | 1485  |
| B    | UL1007 #18 BLK 887711300 | 2   | 2970  |
| A    | UL1007 #18 YEL 887711303 | 1   | 1485  |
| ITEM | DESCRIPTION              | QTY | L(mm) |

|   |                               |  |                    |                            |                   |   |                        |   |  |  |
|---|-------------------------------|--|--------------------|----------------------------|-------------------|---|------------------------|---|--|--|
| ENTER DESCRIPTION<br>EC NO: DG2005-0009<br>DRWNG:GX YANG<br>CHKD: 2004/08/18<br>APPR:BOCHEN<br>2004/08/18 | QUALITY SYMBOLS<br>▽=0<br>▽=0 | GENERAL TOLERANCES (UNLESS SPECIFIED)                |                    | DIMENSION STYLE<br>MM ONLY |                   | SCALE<br>---  | DESIGN UNITS<br>METRIC | THIRD ANGLE PROJECTION  |  |  |
|   |                               | 4 PLACES ±--- ±---                                   | 3 PLACES ±--- ±--- | 2 PLACES ±--- ±---         | 1 PLACE ±--- ±--- | DRAWN BY<br>GX YANG   | DATE<br>04/08/10       | TITLE<br>S-ATA IDT POWER LATCHING TO PIGTAIL CABLE ASS'Y 1.5M (3.3V+5V+12V) |  |  |
|   |                               | ANGULAR ±---°  |                    |                            |                   | CHECKED BY<br>TEDDY   | DATE<br>04/08/10       |   |  |  |
|   |                               | DRAFT WHERE APPLICABLE MUST REMAIN WITHIN DIMENSIONS |                    |                            |                   | APPROVED BY<br>BORON  | DATE<br>04/08/10       | MOLEX INCORPORATED  |  |  |
| MATERIAL NO.<br>685610022/3   |                               | DOCUMENT NO.<br>SD-68561-005                         |                    | SHEET NO.<br>1 OF 1        |                   | THIS DRAWING CONTAINS INFORMATION THAT IS PROPRIETARY TO MOLEX INCORPORATED AND SHOULD NOT BE USED WITHOUT WRITTEN PERMISSION |                        |   |  |  |

ib\_frame\_A4\_P\_ME\_T  
 Rev. D 2004/04/02

6 5 4 3 2 1