

Microprocessor Monitor

Features

- Precision Voltage Monitor
 - Adjustable +4.5V or +4.75V
- Reset Pulse Width – 250 msec minimum
- No External Components
- Adjustable Watchdog Timer
 - 150 msec, 600 msec or 1.2 sec
- Debounced Manual Reset Input for External Override

Applications

- Computers
- Controllers
- Intelligent Instruments
- Automotive Systems
- Critical μ P Power Monitoring

General Description

The TC1232 is a fully-integrated processor supervisor that provides three important functions to safeguard processor sanity: precision power on/off reset control, watchdog timer and external reset override.

On power-up, the TC1232 holds the processor in the reset state for a minimum of 250 msec after V_{CC} is within tolerance to ensure a stable system start-up.

Microprocessor sanity is monitored by the on-board watchdog circuit. The microprocessor must provide a periodic low-going signal on the \overline{ST} input. Should the processor fail to supply this signal within the selected time-out period (150 msec, 600 msec or 1200 msec), an out-of-control processor is indicated and the TC1232 issues a processor reset as a result.

The outputs of the TC1232 are immediately driven active when the PB input is brought low by an external push-button switch or other electronic signal. When connected to a push-button switch, the TC1232 provides contact debounce.

The TC1232 is packaged in a space-saving 8-Pin PDIP or SOIC package and a 16-Pin SOIC (Wide) package and requires no external components.

Package Types

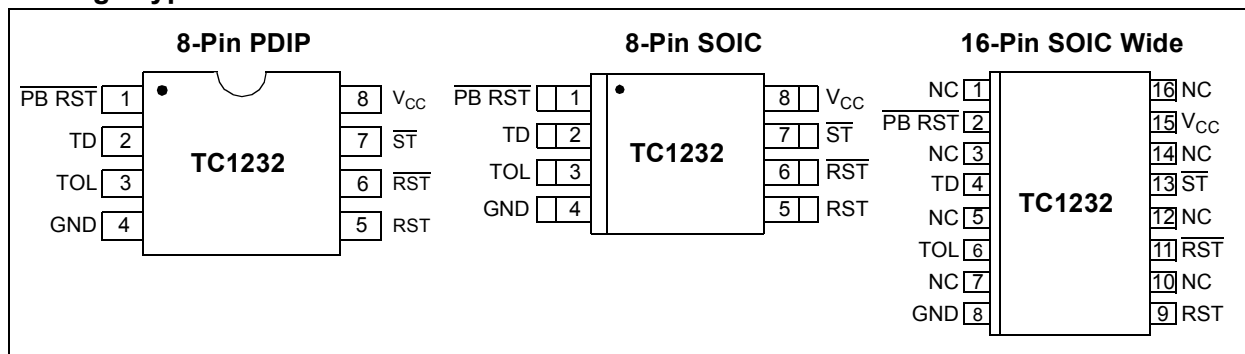

TC1232

Functional Block Diagram

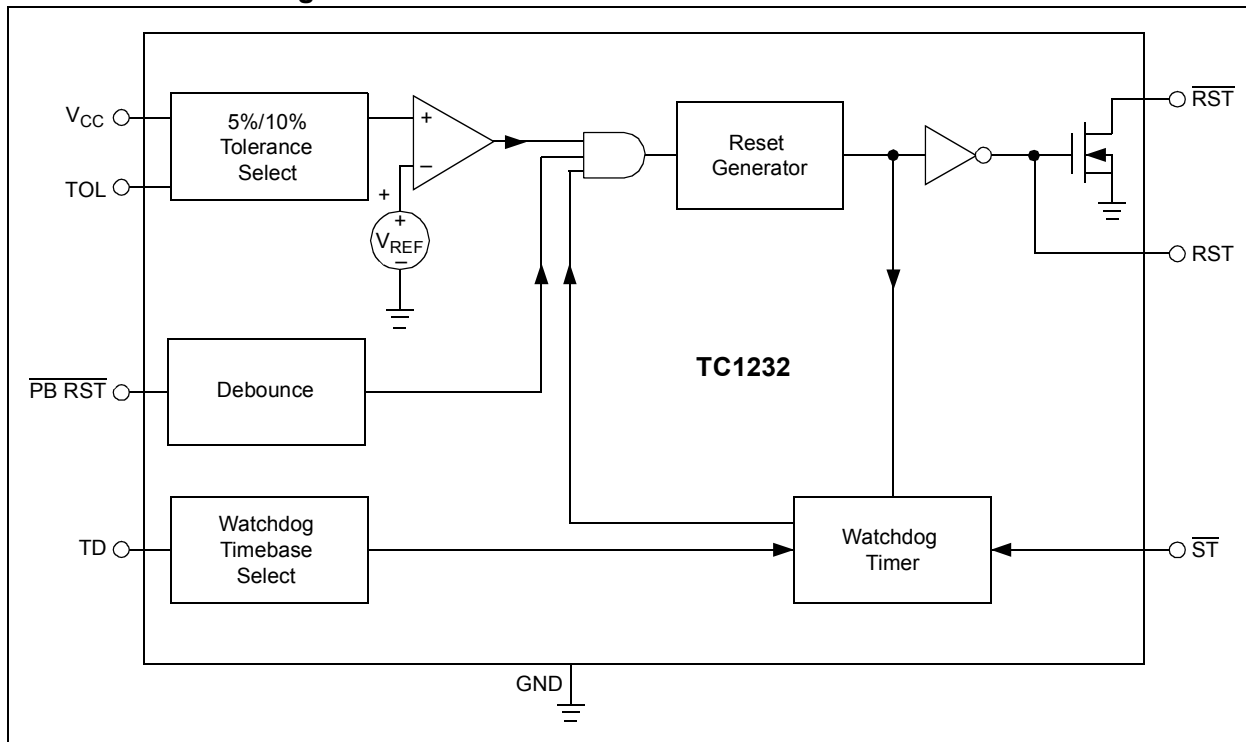

1.0 ELECTRICAL CHARACTERISTICS

Absolute Maximum Ratings†

Voltage on Any Pin (With Respect to GND)	-0.3V to +5.8V
Operating Temperature Range	
C-Version	0°C to +70°C
E-Version	-40°C to +85°C
Storage Temperature Range	-65°C to +150°C

† Stresses above those listed under "Absolute Maximum Ratings" may cause permanent damage to the device. These are stress ratings only and functional operation of the device at these or any other conditions above those indicated in the operation sections of the specifications is not implied. Exposure to Absolute Maximum Rating conditions for extended periods may affect device reliability.

DC CHARACTERISTICS

Electrical Specifications: Unless otherwise noted, $T_A = T_{MIN}$ to T_{MAX} ; $V_{CC} = +4.5V$ to $5.5V$.						
Parameters	Sym	Min	Typ	Max	Units	Conditions
Supply Voltage	V_{CC}	4.5	5.0	5.5	V	
\overline{ST} and $\overline{PB RST}$ Input High Level	V_{IH}	2.0	—	$V_{CC} + 0.3$	V	Note 1
\overline{ST} and $\overline{PB RST}$ Input Low Level	V_{IL}	-0.3	—	+0.8	V	
Input Leakage \overline{ST} , TOL	I_L	-1.0	—	+1.0	μA	
Output Current RST	I_{OH}	-1.0	-12	—	mA	$V_{OH} = 2.4V$
Current \overline{RST} , \overline{RST}	I_{OL}	2.0	10	—	mA	$V_{OL} = 0.4V$
Operating Current	I_{CC}	—	50	200	μA	Note 2
V_{CC} 5% Trip Point	V_{CCTP}	4.50	4.62	4.74	V	TOL = GND (Note 3)
V_{CC} 10% Trip Point	V_{CCTP}	4.25	4.37	4.49	V	TOL = V_{CC} (Note 3)
Capacitance Electrical Characteristics: Unless otherwise noted, $T_A = +25^\circ C$. (Note 4)						
Input Capacitance \overline{ST} , TOL	C_{IN}	—	—	5	pF	
Output Capacitance RST, \overline{RST}	C_{OUT}	—	—	7	pF	
AC Electrical Characteristics: Unless otherwise noted, $T_A = T_{MIN}$ to T_{MAX} ; $V_{CC} = +5V$ to $\pm 10\%$.						
$\overline{PB RST}$	t_{PB}	20	—	—	msec	Figure 3-3 (Note 5)
$\overline{PB RST}$ Delay	t_{PBD}	1	4	20	msec	Figure 3-3
Reset Active Time	t_{RST}	250	610	1000	msec	
\overline{ST} Pulse Width	t_{ST}	20	—	—	nsec	Figure 3-4
\overline{ST} Time-out Period	t_{TD}	62.5	150	250	msec	TD Pin = 0V, Figure 3-4
		250	600	1000	msec	TD Pin = Open, Figure 3-4
		500	1200	2000	msec	TD Pin = V_{CC} , Figure 3-4
V_{CC} Fall Time	t_F	10	—	—	μsec	Figure 3-5, (Note 4)
V_{CC} Rise Time	t_R	0	—	—	μsec	Figure 3-6, (Note 4)
V_{CC} Detect to RST High and \overline{RST} Low	t_{RPD}	—	—	100	nsec	Figure 3-7, V_{CC} Falling
V_{CC} Detect to RST High and \overline{RST} Open	t_{RPU}	250	610	1000	msec	Figure 3-8, V_{CC} Rising, (Note 6)

- Note 1:** $\overline{PB RST}$ is internally pulled up to V_{CC} with an internal impedance of typically 40 k Ω .
2: Measured with outputs open.
3: All voltages referenced to GND.
4: Ensured by design.
5: $\overline{PB RST}$ must be held low for a minimum of 20 msec to ensure a reset.
6: $t_R = 5 \mu sec$.

TC1232

2.0 PIN DESCRIPTIONS

The descriptions of the pins are listed in Table 2-1.

TABLE 2-1: PIN FUNCTION TABLE

Pin No. (8-pin PDIP, SOIC)	Pin No. (16-pin SOIC)	Symbol	Function
1	2	$\overline{\text{PB RST}}$	Push-button Reset Input. A debounced active-low input that ignores pulses less than 1 msec in duration and is ensured to recognize inputs of 20 msec or greater.
2	4	TD	Time Delay Set. The watchdog time-out select input ($t_{\text{TD}} = 150$ msec for TD = 0V, $t_{\text{TD}} = 600$ msec for TD = open, $t_{\text{TD}} = 1.2$ sec for TD = V_{CC}).
3	6	TOL	Tolerance Input. Connect to GND for 5% tolerance or to V_{CC} for 10% tolerance.
4	8	GND	Ground.
5	9	RST	Reset Output (Active-High) – goes active: 1. If V_{CC} falls below the selected reset voltage threshold. 2. If $\overline{\text{PB RST}}$ is forced low. 3. If $\overline{\text{ST}}$ is not strobed within the minimum time-out period. 4. During power-up
6	$\overline{11}$	$\overline{\text{RST}}$	Reset output (active-low, open-drain) – see RST.
7	$\overline{13}$	$\overline{\text{ST}}$	Strobe input. Input for watchdog timer.
8	15	V_{CC}	The +5V power-supply input.
—	1,3,5,7,10,12,16	NC	No internal connection.

3.0 DETAILED DESCRIPTION

3.1 Power Monitor

The TC1232 provides the function of warning the processor of a power failure. When V_{CC} is detected as being below the voltage levels defined by the TOL pin, the TC1232's comparator outputs the RST and \overline{RST} signals to a logic level that warns the system of an out-of-tolerance power supply. The RST and \overline{RST} signals switch at a threshold value of 4.5V if TOL is tied to V_{CC} and at a value of 4.75 volts if TOL is grounded. The RST and \overline{RST} signals are held active for a minimum of 250 msec to ensure that the power supply voltage has been stabilized.

3.2 Push-Button Reset Input

The debounced manual reset input ($\overline{PB\ RST}$) manually forces the reset outputs into their active states. Once $\overline{PB\ RST}$ has been low for a time t_{PBD} (the push-button delay time) the reset outputs go active. The reset outputs remain in their active states for a minimum of 250 msec after $\overline{PB\ RST}$ rises above V_{IH} (Figure 3-3).

A mechanical push-button or active logic signal can drive the $\overline{PB\ RST}$ input. The debounced input ignores input pulses less than 1 msec and recognizes pulses of 20 msec or greater. No external pull-up resistor is required because the $\overline{PB\ RST}$ input has an internal pull-up to V_{CC} of approximately 100 μA .

3.3 Watchdog Timer

When the \overline{ST} input is not stimulated for a preset time period, the watchdog timer function forces RST and \overline{RST} signals to the active state. The preset time period is determined by the \overline{TD} inputs to be 150 msec with TD connected to ground, 600 msec with TD floating, or 1200 msec with TD connected to V_{CC} (typical). The watchdog timer starts timing-out from the set time period as soon as RST and \overline{RST} are inactive. If a high-to-low transition occurs on the ST input pin prior to time-out, the watchdog timer is reset and begins to time-out again. If the watchdog timer is allowed to time-out, then the RST and \overline{RST} signals are driven to the active state for 250 msec minimum (Figure 3-2).

The software routine that strobes \overline{ST} is critical. The code must be in a section of software that is executed frequently enough so the time between toggles is less than the watchdog time-out period. One common technique controls the μP I/O line from two sections of the program. The software might set the I/O line high while operating in the foreground mode and set it low while in the background or interrupt mode. If both modes do not execute correctly, the watchdog timer issues reset pulses.

3.4 Supply Monitor Noise Sensitivity

The TC1232 is optimized for fast response to negative-going changes in V_{DD} . Systems with an inordinate amount of electrical noise on V_{DD} (such as systems using relays) may require a 0.01 μF or 0.1 μF bypass capacitor to reduce detection sensitivity. This capacitor should be installed as close to the TC1232 as possible to keep the capacitor lead length short.

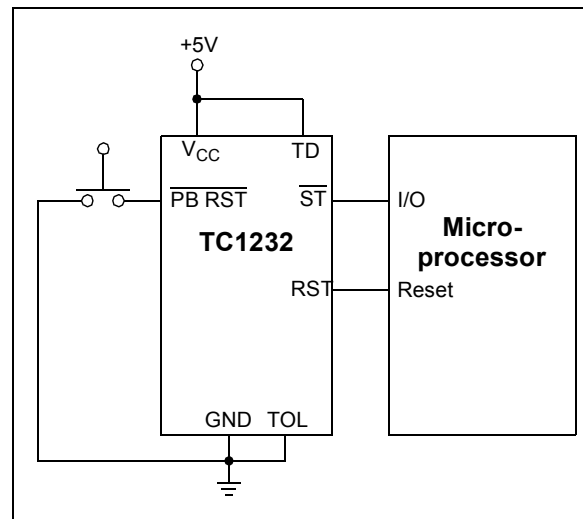

FIGURE 3-1: Push-Button Reset.

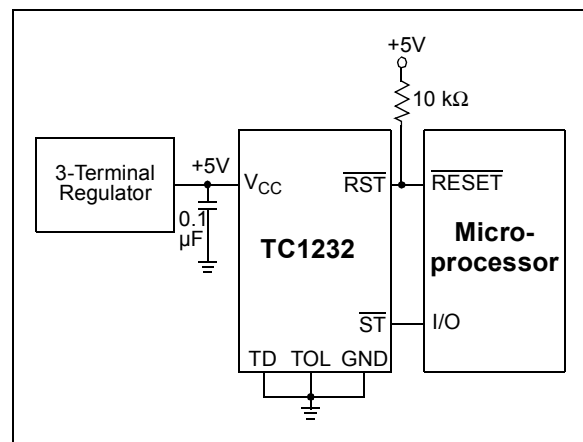

FIGURE 3-2: Watchdog Timer.

TC1232

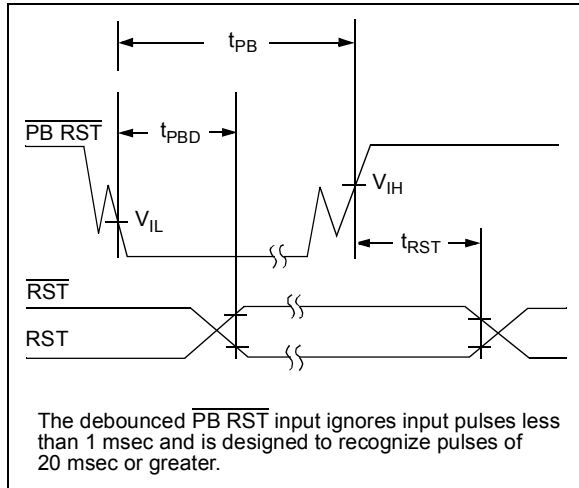

FIGURE 3-3: Push-Button Reset – $\overline{\text{PB RST}}$ Input.

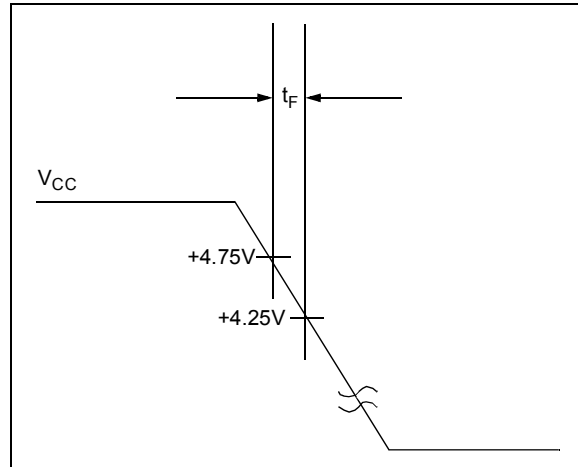

FIGURE 3-5: Power-Down Slew Rate.

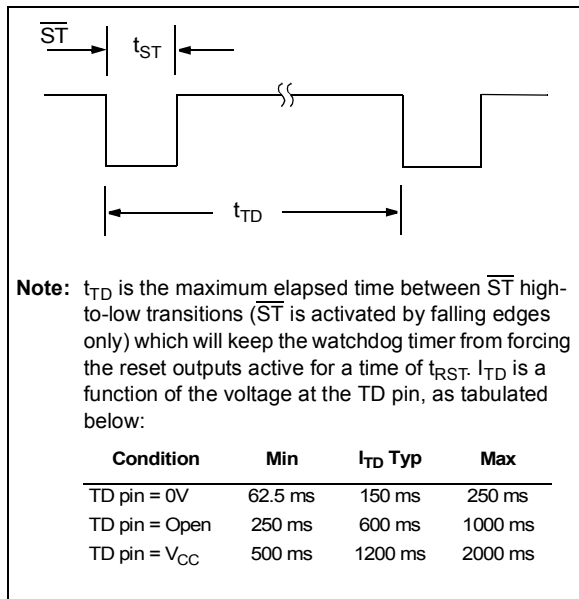

FIGURE 3-4: Strobe Input.

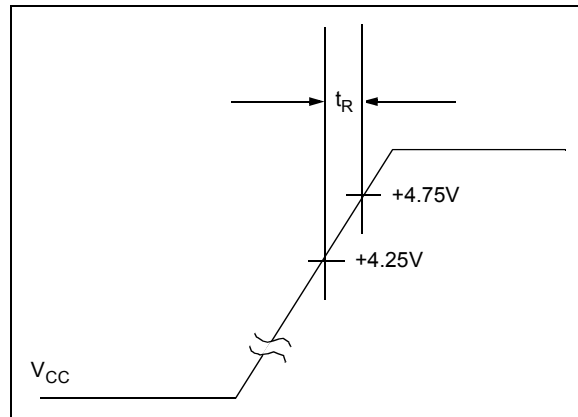

FIGURE 3-6: Power-up Slew Rate.

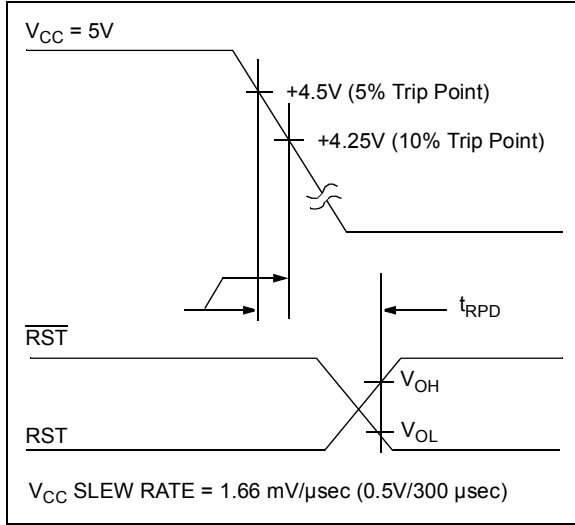

FIGURE 3-7: V_{CC} Detect Reset Output Delay (Power-Down).

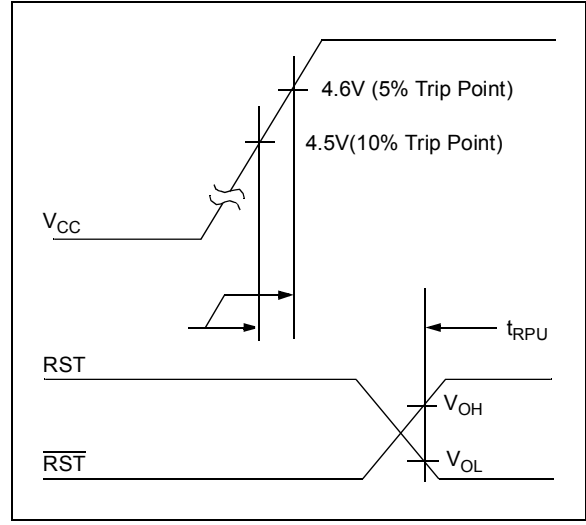

FIGURE 3-8: V_{CC} Detect Reset Output Delay (Power-Up).

TC1232

4.0 PACKAGING INFORMATION

4.1 Package Marking Information

8-Lead PDIP (300 mil)

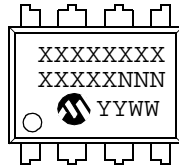

Example:

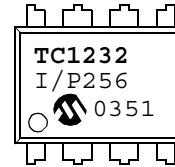

8-Lead SOIC (150 mil)

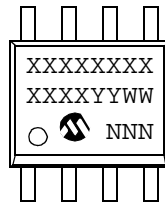

Example:

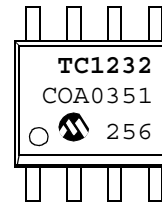

16-Lead SOIC (150 mil)

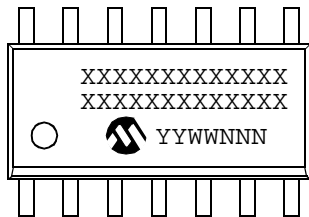

Example:

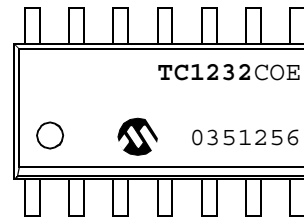

Legend:	XX...X	Customer specific information*
	YY	Year code (last 2 digits of calendar year)
	WW	Week code (week of January 1 is week '01')
	NNN	Alphanumeric traceability code
Note:	In the event the full Microchip part number cannot be marked on one line, it will be carried over to the next line thus limiting the number of available characters for customer specific information.	

* Standard OTP marking consists of Microchip part number, year code, week code, and traceability code.

8-Lead Plastic Dual In-line (PA) – 300 mil (PDIP)

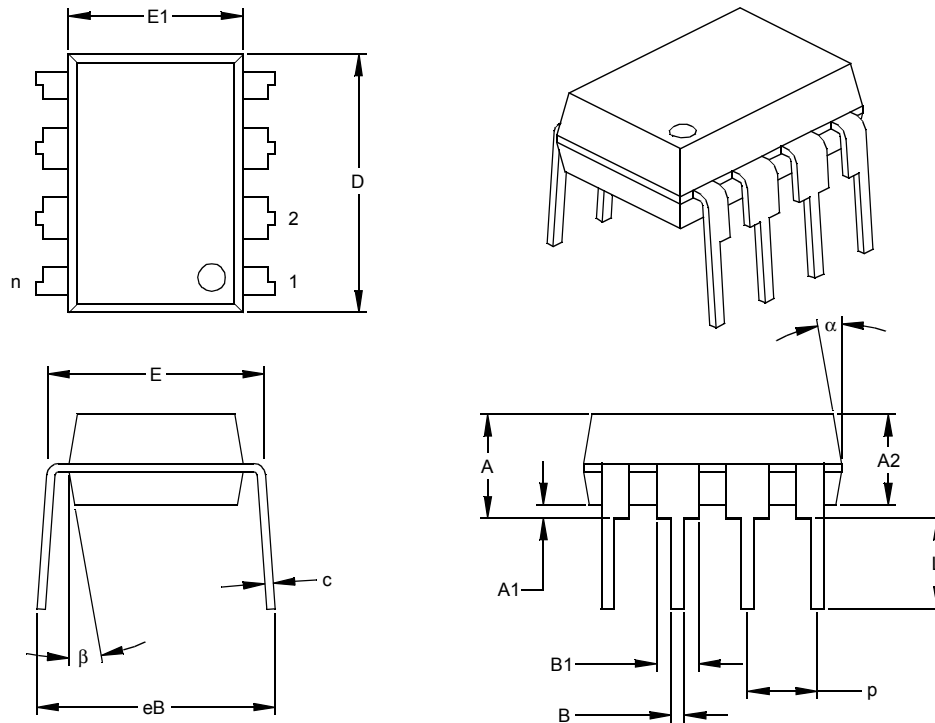

Units		INCHES*			MILLIMETERS		
Dimension Limits		MIN	NOM	MAX	MIN	NOM	MAX
Number of Pins	n		8			8	
Pitch	p		.100			2.54	
Top to Seating Plane	A	.140	.155	.170	3.56	3.94	4.32
Molded Package Thickness	A2	.115	.130	.145	2.92	3.30	3.68
Base to Seating Plane	A1	.015			0.38		
Shoulder to Shoulder Width	E	.300	.313	.325	7.62	7.94	8.26
Molded Package Width	E1	.240	.250	.260	6.10	6.35	6.60
Overall Length	D	.360	.373	.385	9.14	9.46	9.78
Tip to Seating Plane	L	.125	.130	.135	3.18	3.30	3.43
Lead Thickness	c	.008	.012	.015	0.20	0.29	0.38
Upper Lead Width	B1	.045	.058	.070	1.14	1.46	1.78
Lower Lead Width	B	.014	.018	.022	0.36	0.46	0.56
Overall Row Spacing	§ eB	.310	.370	.430	7.87	9.40	10.92
Mold Draft Angle Top	α	5	10	15	5	10	15
Mold Draft Angle Bottom	β	5	10	15	5	10	15

* Controlling Parameter
 § Significant Characteristic

Notes:

Dimensions D and E1 do not include mold flash or protrusions. Mold flash or protrusions shall not exceed .010" (0.254mm) per side.
 JEDEC Equivalent: MS-001
 Drawing No. C04-018

TC1232

8-Lead Plastic Small Outline (OA) – Narrow, 150 mil (SOIC)

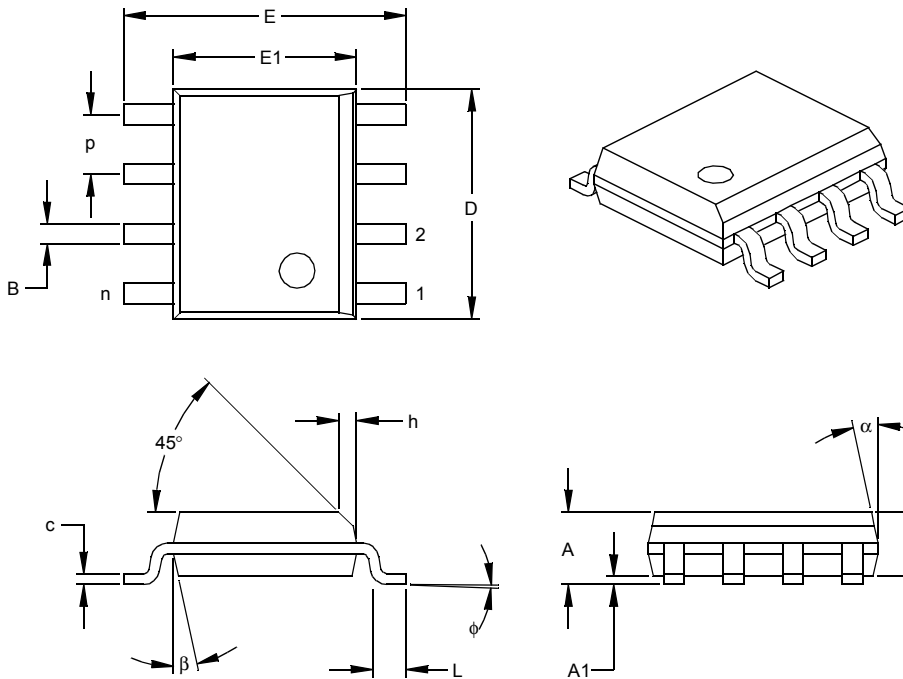

Dimension Limits	Units	INCHES*			MILLIMETERS		
		MIN	NOM	MAX	MIN	NOM	MAX
Number of Pins	n		8			8	
Pitch	p		.050			1.27	
Overall Height	A	.053	.061	.069	1.35	1.55	1.75
Molded Package Thickness	A2	.052	.056	.061	1.32	1.42	1.55
Standoff §	A1	.004	.007	.010	0.10	0.18	0.25
Overall Width	E	.228	.237	.244	5.79	6.02	6.20
Molded Package Width	E1	.146	.154	.157	3.71	3.91	3.99
Overall Length	D	.189	.193	.197	4.80	4.90	5.00
Chamfer Distance	h	.010	.015	.020	0.25	0.38	0.51
Foot Length	L	.019	.025	.030	0.48	0.62	0.76
Foot Angle	φ	0	4	8	0	4	8
Lead Thickness	c	.008	.009	.010	0.20	0.23	0.25
Lead Width	B	.013	.017	.020	0.33	0.42	0.51
Mold Draft Angle Top	α	0	12	15	0	12	15
Mold Draft Angle Bottom	β	0	12	15	0	12	15

* Controlling Parameter
 § Significant Characteristic

Notes:

Dimensions D and E1 do not include mold flash or protrusions. Mold flash or protrusions shall not exceed .010" (0.254mm) per side.

JEDEC Equivalent: MS-012

Drawing No. C04-057

16-Lead Plastic Small Outline (OE) – Wide, 300 mil (SOIC)

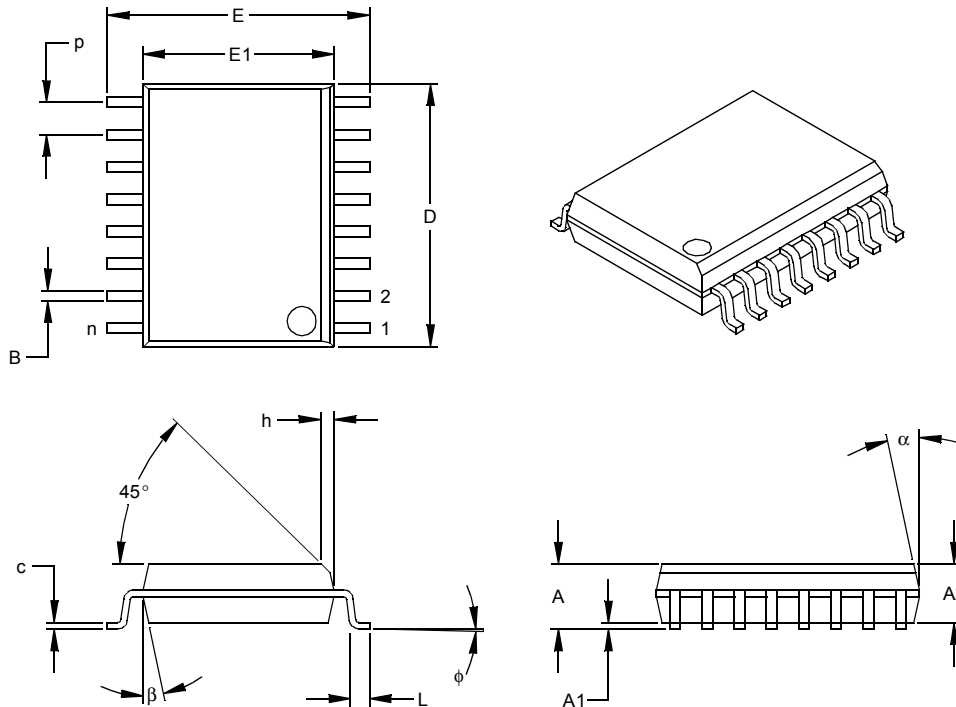

Units		INCHES*			MILLIMETERS		
Dimension Limits		MIN	NOM	MAX	MIN	NOM	MAX
Number of Pins	n		16			16	
Pitch	p		.050			1.27	
Overall Height	A	.093	.099	.104	2.36	2.50	2.64
Molded Package Thickness	A2	.088	.091	.094	2.24	2.31	2.39
Standoff §	A1	.004	.008	.012	0.10	0.20	0.30
Overall Width	E	.394	.407	.420	10.01	10.34	10.67
Molded Package Width	E1	.291	.295	.299	7.39	7.49	7.59
Overall Length	D	.398	.406	.413	10.10	10.30	10.49
Chamfer Distance	h	.010	.020	.029	0.25	0.50	0.74
Foot Length	L	.016	.033	.050	0.41	0.84	1.27
Foot Angle	φ	0	4	8	0	4	8
Lead Thickness	c	.009	.011	.013	0.23	0.28	0.33
Lead Width	B	.014	.017	.020	0.36	0.42	0.51
Mold Draft Angle Top	α	0	12	15	0	12	15
Mold Draft Angle Bottom	β	0	12	15	0	12	15

* Controlling Parameter
 § Significant Characteristic

Notes:

Dimensions D and E1 do not include mold flash or protrusions. Mold flash or protrusions shall not exceed .010" (0.254mm) per side.

JEDEC Equivalent: MS-013

Drawing No. C04-102

TC1232

NOTES:

PRODUCT IDENTIFICATION SYSTEM

To order or obtain information, e.g., on pricing or delivery, refer to the factory or the listed sales office.

<u>PART NO.</u>	<u>X</u>	<u>/XX</u>
Device	Temperature Range	Package
Device: TC1232: Microprocessor Monitor	Temperature Range: C = 0°C to +70°C E = -40°C to +85°C	Package: PA = Plastic DIP (300 mil Body), 8-lead OA = Plastic SOIC, (150 mil Body), 8-lead OA713 = Plastic SOIC, (150 mil Body), 8-lead Tape and Reel OE = Plastic SOIC (300 mil Body), 16-lead OE713 = Plastic SOIC (300 mil Body), 16-lead Tape and Reel
Examples: a) TC1232COA: 0°C to +70°C, 8L-SOIC b) TC1232COA713: 0°C to +70°C, 8L-SOIC, Tape and Reel c) TC1232COE: 0°C to +70°C, 16L-SOIC d) TC1232COE713: 0°C to +70°C, 16L-SOIC, Tape and Reel e) TC1232CPA: 0°C to +70°C, 8L-PDIP f) TC1232EOA: -40°C to +85°C, 8L-SOIC g) TC1232EOA713: -40°C to +85°C, 8L-SOIC, Tape and Reel h) TC1232EOE: -40°C to +85°C, 16L-SOIC i) TC1232EOE713: -40°C to +85°C, 16L-SOIC, Tape and Reel j) TC1232EPA: -40°C to +85°C, 8L-PDIP		

Sales and Support

Data Sheets

Products supported by a preliminary Data Sheet may have an errata sheet describing minor operational differences and recommended workarounds. To determine if an errata sheet exists for a particular device, please contact one of the following:

1. Your local Microchip sales office
2. The Microchip Corporate Literature Center U.S. FAX: (480) 792-7277
3. The Microchip Worldwide Site (www.microchip.com)

Please specify which device, revision of silicon and Data Sheet (include Literature #) you are using.

Customer Notification System

Register on our web site (www.microchip.com/cn) to receive the most current information on our products.

TC1232

NOTES:

Note the following details of the code protection feature on Microchip devices:

- Microchip products meet the specification contained in their particular Microchip Data Sheet.
- Microchip believes that its family of products is one of the most secure families of its kind on the market today, when used in the intended manner and under normal conditions.
- There are dishonest and possibly illegal methods used to breach the code protection feature. All of these methods, to our knowledge, require using the Microchip products in a manner outside the operating specifications contained in Microchip's Data Sheets. Most likely, the person doing so is engaged in theft of intellectual property.
- Microchip is willing to work with the customer who is concerned about the integrity of their code.
- Neither Microchip nor any other semiconductor manufacturer can guarantee the security of their code. Code protection does not mean that we are guaranteeing the product as "unbreakable."

Code protection is constantly evolving. We at Microchip are committed to continuously improving the code protection features of our products. Attempts to break microchip's code protection feature may be a violation of the Digital Millennium Copyright Act. If such acts allow unauthorized access to your software or other copyrighted work, you may have a right to sue for relief under that Act.

Information contained in this publication regarding device applications and the like is intended through suggestion only and may be superseded by updates. It is your responsibility to ensure that your application meets with your specifications. No representation or warranty is given and no liability is assumed by Microchip Technology Incorporated with respect to the accuracy or use of such information, or infringement of patents or other intellectual property rights arising from such use or otherwise. Use of Microchip's products as critical components in life support systems is not authorized except with express written approval by Microchip. No licenses are conveyed, implicitly or otherwise, under any intellectual property rights.

Trademarks

The Microchip name and logo, the Microchip logo, KEELOQ, MPLAB, PIC, PICmicro, PICSTART, PRO MATE and PowerSmart are registered trademarks of Microchip Technology Incorporated in the U.S.A. and other countries.

FilterLab, microID, MXDEV, MXLAB, PICMASTER, SEEVAL and The Embedded Control Solutions Company are registered trademarks of Microchip Technology Incorporated in the U.S.A.

Accuron, Application Maestro, dsPIC, dsPICDEM, dsPICDEM.net, ECONOMONITOR, FanSense, FlexROM, fuzzyLAB, In-Circuit Serial Programming, ICSP, ICEPIC, microPort, Migratable Memory, MPASM, MPLIB, MPLINK, MPSIM, PICC, PICkit, PICDEM, PICDEM.net, PowerCal, PowerInfo, PowerMate, PowerTool, rLAB, rPIC, Select Mode, SmartSensor, SmartShunt, SmartTel and Total Endurance are trademarks of Microchip Technology Incorporated in the U.S.A. and other countries.

Serialized Quick Turn Programming (SQTP) is a service mark of Microchip Technology Incorporated in the U.S.A.

All other trademarks mentioned herein are property of their respective companies.

© 2003, Microchip Technology Incorporated, Printed in the U.S.A., All Rights Reserved.

 Printed on recycled paper.

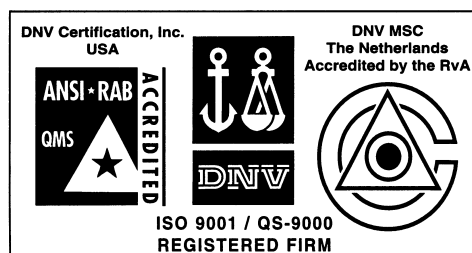

Microchip received QS-9000 quality system certification for its worldwide headquarters, design and wafer fabrication facilities in Chandler and Tempe, Arizona in July 1999 and Mountain View, California in March 2002. The Company's quality system processes and procedures are QS-9000 compliant for its PICmicro® 8-bit MCUs, KEELOQ® code hopping devices, Serial EEPROMs, microperipherals, non-volatile memory and analog products. In addition, Microchip's quality system for the design and manufacture of development systems is ISO 9001 certified.



WORLDWIDE SALES AND SERVICE

AMERICAS

Corporate Office

2355 West Chandler Blvd.
Chandler, AZ 85224-6199
Tel: 480-792-7200 Fax: 480-792-7277
Technical Support: 480-792-7627
Web Address: <http://www.microchip.com>

Atlanta

3780 Mansell Road, Suite 130
Alpharetta, GA 30022
Tel: 770-640-0034 Fax: 770-640-0307

Boston

2 Lan Drive, Suite 120
Westford, MA 01886
Tel: 978-692-3848 Fax: 978-692-3821

Chicago

333 Pierce Road, Suite 180
Itasca, IL 60143
Tel: 630-285-0071 Fax: 630-285-0075

Dallas

4570 Westgrove Drive, Suite 160
Addison, TX 75001
Tel: 972-818-7423 Fax: 972-818-2924

Detroit

Tri-Atria Office Building
32255 Northwestern Highway, Suite 190
Farmington Hills, MI 48334
Tel: 248-538-2250 Fax: 248-538-2260

Kokomo

2767 S. Albright Road
Kokomo, Indiana 46902
Tel: 765-864-8360 Fax: 765-864-8387

Los Angeles

18201 Von Karman, Suite 1090
Irvine, CA 92612
Tel: 949-263-1888 Fax: 949-263-1338

Phoenix

2355 West Chandler Blvd.
Chandler, AZ 85224-6199
Tel: 480-792-7966 Fax: 480-792-4338

San Jose

Microchip Technology Inc.
2107 North First Street, Suite 590
San Jose, CA 95131
Tel: 408-436-7950 Fax: 408-436-7955

Toronto

6285 Northam Drive, Suite 108
Mississauga, Ontario L4V 1X5, Canada
Tel: 905-673-0699 Fax: 905-673-6509

ASIA/PACIFIC

Australia

Microchip Technology Australia Pty Ltd
Marketing Support Division
Suite 22, 41 Rawson Street
Epping 2121, NSW
Australia
Tel: 61-2-9868-6733 Fax: 61-2-9868-6755

China - Beijing

Microchip Technology Consulting (Shanghai)
Co., Ltd., Beijing Liaison Office
Unit 915
Bei Hai Wan Tai Bldg.
No. 6 Chaoyangmen Beidajie
Beijing, 100027, No. China
Tel: 86-10-85282100 Fax: 86-10-85282104

China - Chengdu

Microchip Technology Consulting (Shanghai)
Co., Ltd., Chengdu Liaison Office
Rm. 2401-2402, 24th Floor,
Ming Xing Financial Tower
No. 88 TIDU Street
Chengdu 610016, China
Tel: 86-28-86766200 Fax: 86-28-86766599

China - Fuzhou

Microchip Technology Consulting (Shanghai)
Co., Ltd., Fuzhou Liaison Office
Unit 28F, World Trade Plaza
No. 71 Wusi Road
Fuzhou 350001, China
Tel: 86-591-7503506 Fax: 86-591-7503521

China - Hong Kong SAR

Microchip Technology Hongkong Ltd.
Unit 901-6, Tower 2, Metroplaza
223 Hing Fong Road
Kwai Fong, N.T., Hong Kong
Tel: 852-2401-1200 Fax: 852-2401-3431

China - Shanghai

Microchip Technology Consulting (Shanghai)
Co., Ltd.
Room 701, Bldg. B
Far East International Plaza
No. 317 Xian Xia Road
Shanghai, 200051
Tel: 86-21-6275-5700 Fax: 86-21-6275-5060

China - Shenzhen

Microchip Technology Consulting (Shanghai)
Co., Ltd., Shenzhen Liaison Office
Rm. 1812, 18/F, Building A, United Plaza
No. 5022 Binhe Road, Futian District
Shenzhen 518033, China
Tel: 86-755-82901380 Fax: 86-755-82966626

China - Qingdao

Rm. B505A, Fullhope Plaza,
No. 12 Hong Kong Central Rd.
Qingdao 266071, China
Tel: 86-532-5027355 Fax: 86-532-5027205

India

Microchip Technology Inc.
India Liaison Office
Marketing Support Division
Divyasree Chambers
1 Floor, Wing A (A3/A4)
No. 11, O'Shaughnessey Road
Bangalore, 560 025, India
Tel: 91-80-2290061 Fax: 91-80-2290062

Japan

Microchip Technology Japan K.K.
Benex S-1 6F
3-18-20, Shinyokohama
Kohoku-Ku, Yokohama-shi
Kanagawa, 222-0033, Japan
Tel: 81-45-471-6166 Fax: 81-45-471-6122

Korea

Microchip Technology Korea
168-1, Youngbo Bldg. 3 Floor
Samsung-Dong, Kangnam-Ku
Seoul, Korea 135-882
Tel: 82-2-554-7200 Fax: 82-2-558-5934

Singapore

Microchip Technology Singapore Pte Ltd.
200 Middle Road
#07-02 Prime Centre
Singapore, 188980
Tel: 65-6334-8870 Fax: 65-6334-8850

Taiwan

Microchip Technology (Barbados) Inc.,
Taiwan Branch
11F-3, No. 207
Tung Hua North Road
Taipei, 105, Taiwan
Tel: 886-2-2717-7175 Fax: 886-2-2545-0139

EUROPE

Austria

Microchip Technology Austria GmbH
Durisolstrasse 2
A-4600 Wels
Austria
Tel: 43-7242-2244-399
Fax: 43-7242-2244-393

Denmark

Microchip Technology Nordic ApS
Regus Business Centre
Lautrup høj 1-3
Ballerup DK-2750 Denmark
Tel: 45 4420 9895 Fax: 45 4420 9910

France

Microchip Technology SARL
Parc d'Activite du Moulin de Massy
43 Rue du Saule Trapu
Batiment A - 1er Etage
91300 Massy, France
Tel: 33-1-69-53-63-20 Fax: 33-1-69-30-90-79

Germany

Microchip Technology GmbH
Steinheilstrasse 10
D-85737 Ismaning, Germany
Tel: 49-89-627-144-0
Fax: 49-89-627-144-44

Italy

Microchip Technology SRL
Via Quasimodo, 12
20025 Legnano (MI)
Milan, Italy
Tel: 39-0331-742611 Fax: 39-0331-466781

United Kingdom

Microchip Ltd.
505 Eskdale Road
Winnersh Triangle
Wokingham
Berkshire, England RG41 5TU
Tel: 44 118 921 5869 Fax: 44-118 921-5820

03/25/03