

HARWIN

HAND CRIMP TOOL M22520/2-01

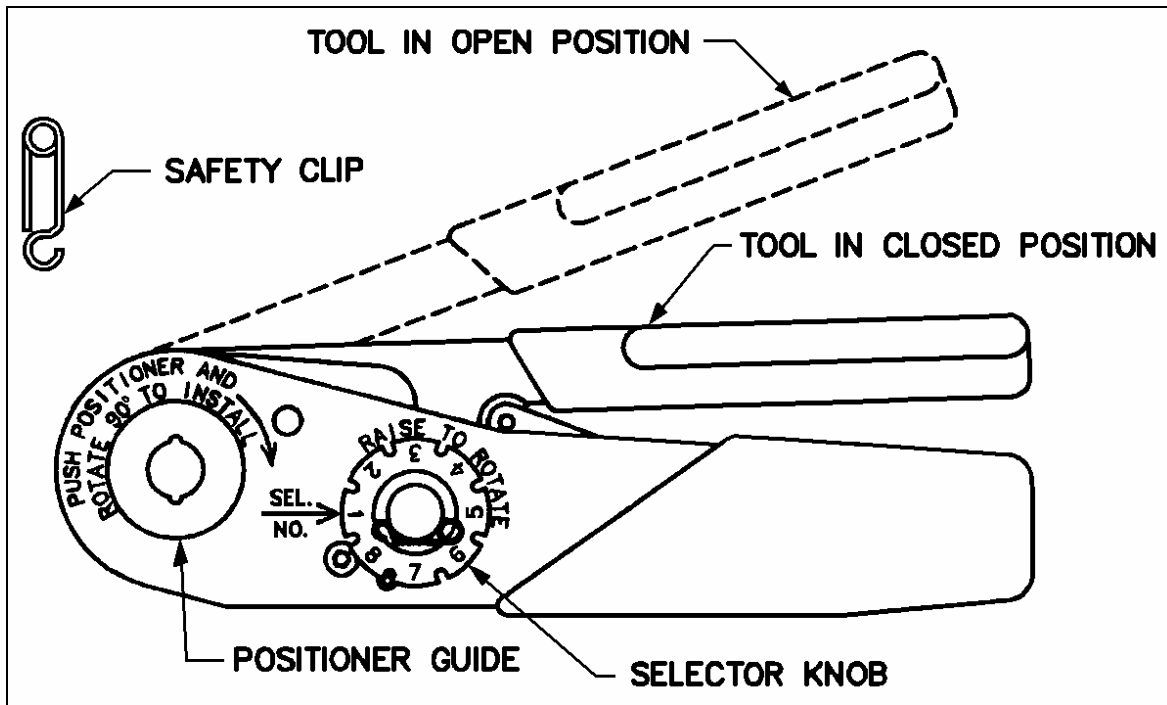

This Hand Crimp Tool has been designed for use with the following Datamate Signal Crimp Sockets (when used with Positioner T5747):

- M80-01100XX..... Large bore Female crimp contact for 22 AWG wire
(used in all L-Tek, J-Tek and Mix-Tek female crimp connectors).
- M80-01300XX..... Small bore Female crimp contact for 24-28 AWG wire
(used in all L-Tek, J-Tek and Mix-Tek female crimp connectors).
- M80-04000XX..... Large bore Male crimp contact for 22 AWG wire
(used in L-Tek male crimp connectors).
- M80-04100XX..... Small bore Male crimp contact for 24-28 AWG wire
(used in L-Tek male crimp connectors).

The following Datamate Signal Crimp Sockets can also be crimped (when used with Positioner Z80-193):

- M80-19400XX..... Large bore Male crimp contact for 22 AWG wire
(used in J-Tek and Mix-Tek male crimp connectors).
- M80-19500XX..... Small bore Male crimp contact for 24-28 AWG wire
(used in J-Tek and Mix-Tek male crimp connectors).

The following Datamate Power Crimp Sockets can also be crimped (when used with Positioner Z80-058):

- M80-05500XX..... Power Female crimp contact for 18-20 AWG
(used in M80-716 and M80-719 series).

The following Power Crimp Sockets can also be crimped (when used with Positioner ZK3609-00):

- K3606-46..... Power Male crimp contact for 18 AWG.
- K3607-46..... Power Female crimp contact for 18 AWG.

Harwin North America

T: +1 603 893 5376 F: +1 603 893 5396
E: misboston@harwin.com W: www.harwin.com

Harwin Europe

T: +44 (0) 23 9231 4545 F: +44 (0) 23 9231 4590
E: mis@harwin.co.uk W: www.harwin.com

Harwin Asia

T: +65 6 779 4909 F: +65 6 779 3868
E: mis@harwin.com.sg W: www.harwin.com.sg

GENERAL INFORMATION

The Hand crimp tool M22520/2-01 consists of a basic hand tool, which should be used with a positioner.

The contact is correctly crimped when the tool is free to open at the fully closed position, i.e., when the ratchet releases. The tool cannot be opened without completing the cycle.

TOOL PREPARATION

1. Check that the tool is in the open position. Remove the safety clip from the positioner guide (do not discard).
2. Insert the Positioner into the positioner guide and turn it 90° in the direction shown on the tool, until the bayonet pins lock.
3. Install the safety clip back into the positioner guide (optional).
4. Check Table 1 for the correct crimp tool setting of the wire size you wish to crimp.
5. Remove the safety clip from the selector knob (do not discard).
6. Lift and turn the selector knob until the correct crimp tool setting is lined up with the "Sel. No." arrow. Lower the selector knob, ensuring the locating peg lines up with a notch.
7. Install the safety clip back into the selector knob.

CRIMPING PROCEDURE

1. Ensure that the wire to be crimped is within the specified range of sizes for the contact and the crimp tool. Failure to use the specified wire size will result in poor quality crimps and possible tool damage.

Table 1

| Contact | Crimp Type | Wire Gauge (AWG) | Stranding (mm) | Crimp Tool Setting | Minimum pull-off force |
|---|-------------|------------------|----------------|--------------------|------------------------|
| M80-01100XX M80-04000XX M80-19400XX | Large Bore | 22 | 19/0.15 | 6 | 50N |
| M80-01300XX M80-04100XX M80-19500XX | Small Bore | 24 | 7/0.2 | 6 | 44N |
| | | 26 | 7/0.15 | 6 | 25N |
| | | 28 | 7/0.12 | 6 | 12.5N |
| M80-05500XX | Power Crimp | 20 | 19/0.2 | 8 | 85N |
| | | 18 | 19/0.26 | 8 | 140N |
| K36XX-46 | Power Crimp | 18 | Variable | 8 | 142N |

2. Cut the end of the cable to be terminated so that there is a clean cut end (Figure A). Strip the cable to the correct length (Figure B) using a PTFE Wire stripper, preferably with adjustable rotating cutter. This should result in all the strands laying together neatly. If the lay of the strands is disturbed, it may be re-imposed with a slight twist.

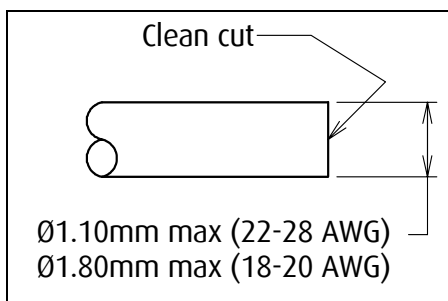

Figure A

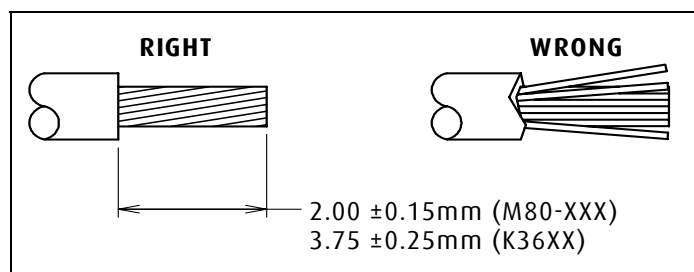

Figure B

3. Position the crimp socket fully into the positioner, with the crimp barrel uppermost.
4. Load the terminated end of the cable into the crimp barrel of the socket. Ensure the wire is fully home, with all strands in place (see Figure C).

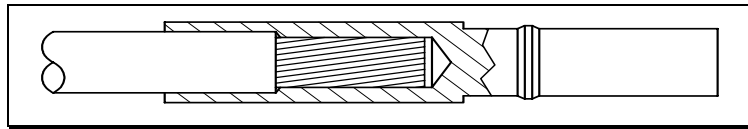

Figure C

5. Squeeze the handles of the crimp tool fully together, until the ratchet releases. The handle will return to the open position. Remove the crimped socket and wire. Using the sight hole on the side wall of the socket, ensure that adequate insertion of strands into the crimp socket has been achieved.
6. Crimp joints should be checked for:
 - a) Correct combination of cable, tool setting and crimp termination.
 - b) Correctness of form and location of crimp.
 - c) Freedom of fracture, rough edges and flash.
 - d) Adequate insertion of all conductor strands in the crimp barrel.
 - e) Absence of damage to the conductor or the insulation.

ASSEMBLY PROCEDURE

M80-XXX piece parts are assembled using the Assembly Tool Z80-280. See Instruction Sheet IS-25 for details on assembly.

K36XX piece parts are assembled using the Assembly Tool ZK3610-00. See Instruction Sheet IS-22 for details on assembly.

CARE OF TOOL

There is virtually no maintenance required for the M22520/2-01 tool. However, it is good practice to keep the indenter tips free of residual colour band deposits and other debris. A small wire brush may be used for this purpose.

We strongly recommend that you:

1. **DO NOT** immerse tools in any cleaning solution.
2. **DO NOT** spray oil into tool to lubricate.
3. **DO NOT** attempt to disassemble tool or make repairs.

This is a precision crimp tool and should be handled as such.