

# ProtoBox –1590BB Kit

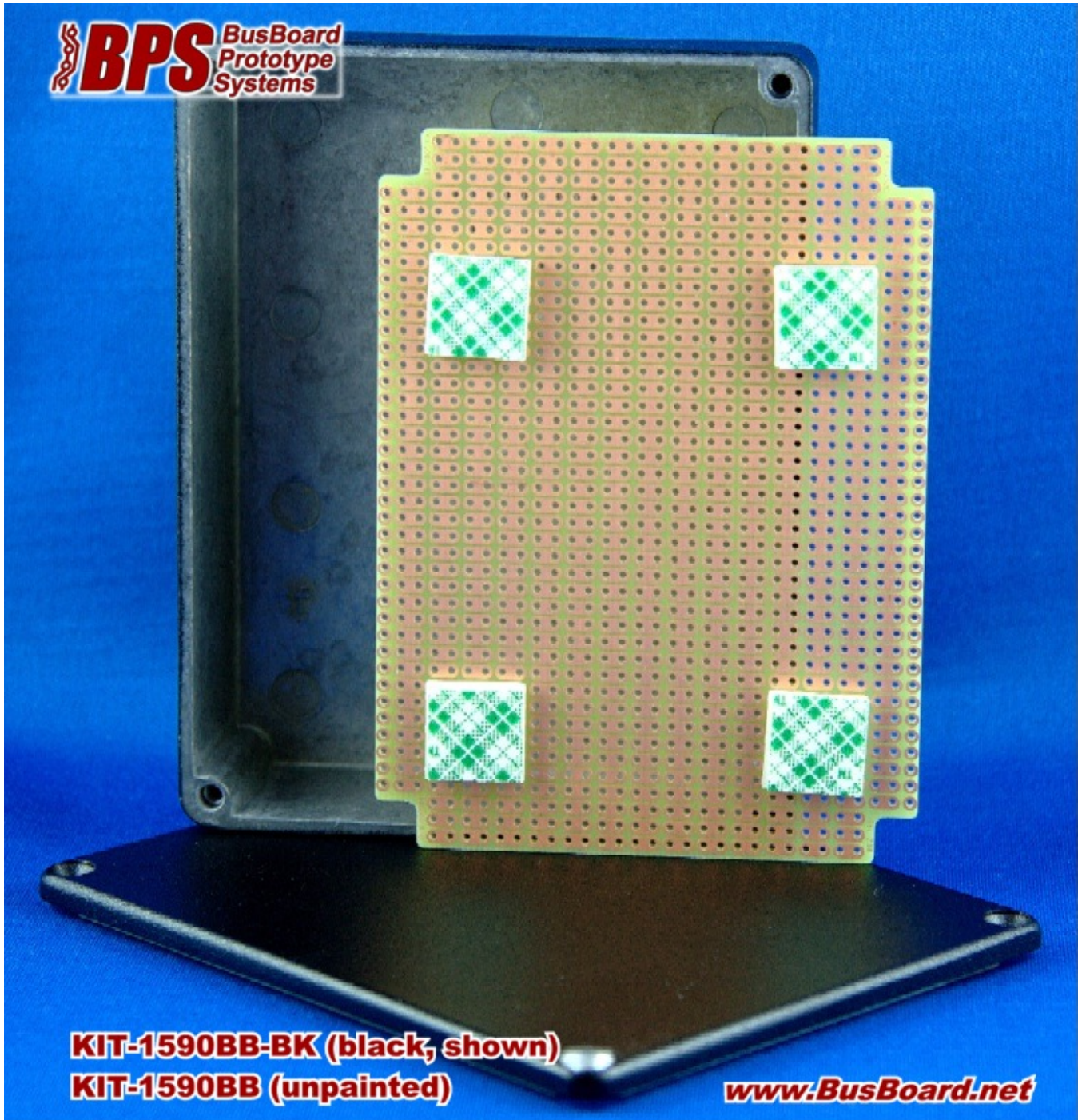

*A Hammond 1590BB rugged die-cast enclosure packaged with a matching ProtoBoard 2-hole per strip PCB.*



**BusBoard Prototype Systems - Built for designers**

[www.BusBoard.net](http://www.BusBoard.net) [sales@busboard.net](mailto:sales@busboard.net)

BPS-MAR-KIT-1590BB-001 Rev 3.01

# ProtoBox-1590BB - ProtoBoard + Box



*Practical and rugged die-cast enclosure with matching circuit board.*

## **PR1590BB Prototyping Board**

*ProtoBoard* saves time! The PCB is designed for the box. No cutting required.

Convenient 2-hole ProtoBoard pattern provides an easy way to connect parts while maximizing usable board area.

**Lead free** etched copper PCB with a flux coating for easy soldering and to preserve solderability.

High-quality FR4 glass epoxy board.

PCB fits in the bottom of box or the top lid.

Four 4-40 size PCB mounting holes.

Single sided, 1oz/ft<sup>2</sup> copper PCB

0.042" holes drilled on 0.1" centers

PCB Size 4.25 x 3.20 in. (108 x 81mm)

**Order Part# PR1590BB**

## **PCB Layout**

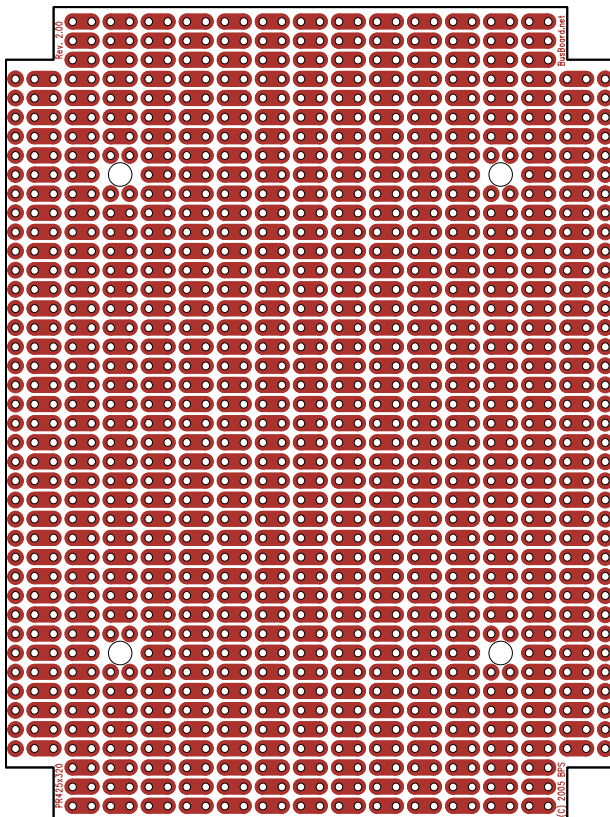

## **1590BB Enclosure**

Rugged diecast aluminum alloy electronic instrument enclosure. Tough - yet easy to machine.

Lap joint construction provides protection from dust and splashing water and also provides for improved EMI/RFI shielding. Designed to meet IP54 dust and water protection standard.

Unpainted box is vibra finished for a smooth surface with no sharp edges. A black painted version is available by special order.

Four 6-32 x 1/2" machine screws (included) secure lid into factory tapped holes.

Box Size 4.67 x 3.68 x 1.18 in. (119 x 94 x 30 mm)

**Order Part#**

**KIT-1590BB (Unpainted Box + PCB)**

**KIT-1590BB-BK (Black Box + PCB)**



**BusBoard Prototype Systems - Built for designers**

[www.BusBoard.net](http://www.BusBoard.net) [sales@busboard.net](mailto:sales@busboard.net)

BPS-MAR-PR1590BB-001 Rev 3.00

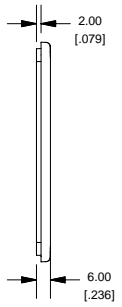
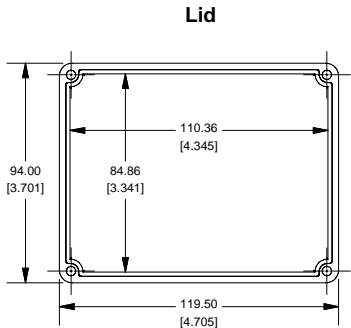
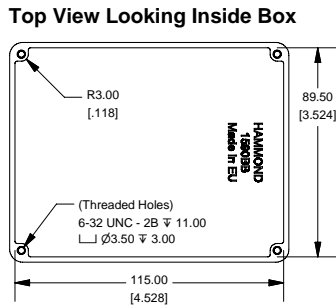
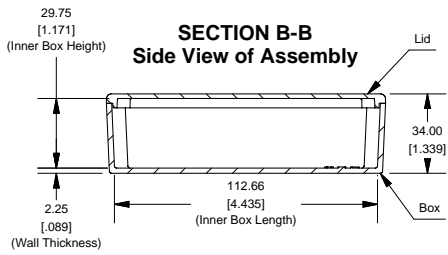
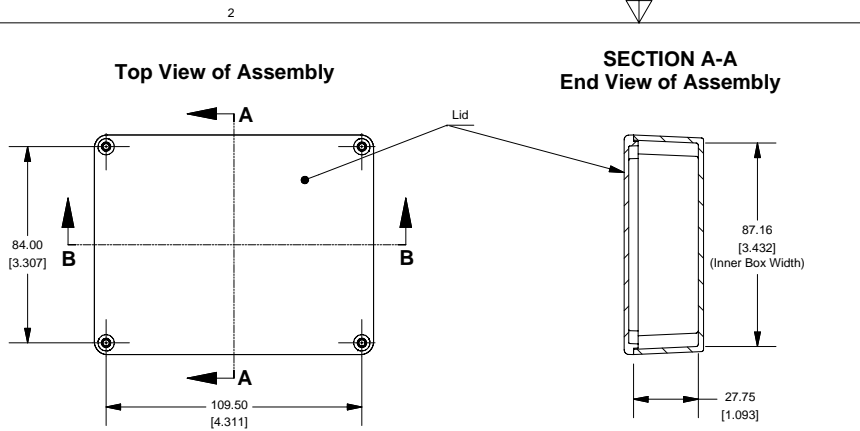

Enclosures can be Factory Modified ( Milling, Drilling, Printing etc.)  
 Contact Factory [mjm@hammondmfg.com](mailto:mjm@hammondmfg.com) for quotes  
 Solid models of this enclosure available in STEP or IGES.

NOTE	
Purchased assembly includes box, lid and 4 cover screws.	
Box and lid are made from Die-cast Aluminum Alloy (alloy type 380).	
Silicone Gasket Loctite #5950	
PART NUMBERS	
1590BB Enclosure	
Unfinished	1590BB
Grey Textured Polyester Powder Paint - RAL 7038	1590BBGY
Black Textured Polyester Powder Paint - RAL 9011	1590BBBK
1590BB Liquid Resistant Enclosure (Silicon Factory Installed Gaskets)	
Unfinished	1590WBB
Black Textured Powder Paint	1590WBBBK
ACCESSORIES	
Recommended Torque: 75 oz.in / 55 cN.m	
Black Textured Cover Screws (Pkg 50) [6-32 x 1/2" SS Type 304]	1590WMS100BK
Unfinished Cover Screws (Pkg 100) [6-32 x 1/2" Nickel Plated Screws]	1590WMS100
Standard Cover Screws	
Unfinished Cover Screws (Pkg 100) [6-32 x 1/2" Nickel Plated Screws]	1590MS100
Black Textured Cover Screws (Pkg 50) [6-32 x 1/2" SS Type 304]	1590MS100BK

**HAMMOND MANUFACTURING™**  
 1590BB  
[www.hammondmfg.com](http://www.hammondmfg.com)