

## Model 3957 BNC (Male) To Multi-Stacking Banana Plugs

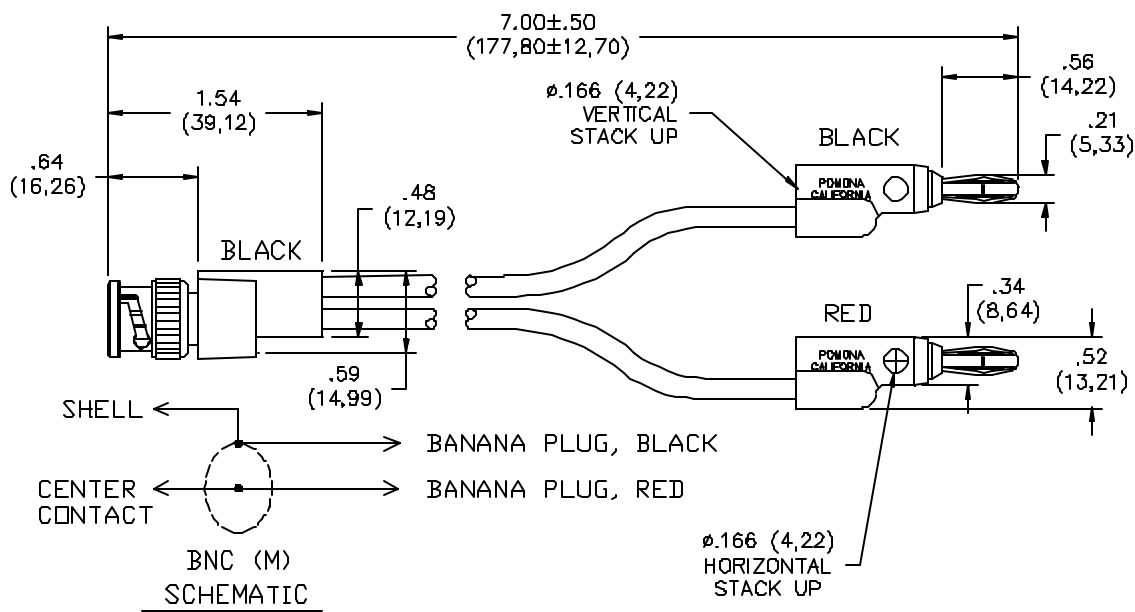

Wire: 18 AWG, Stranding 65 x 36 T.C., PVC Insulated, .144" (3,66mm) O.D., Color matches banana plugs

Marking: "POMONA 3957"

Banana Plugs: Body – Brass Nickel Plated

Spring – Beryllium Copper, Nickel Plated

Insulation: Polypropylene Color: One

Red, One Black

### RATINGS:

Operating Voltage: Hand-Held testing:

30VAC/60VDC Max.

Hands free testing in controlled

voltage environments: 500 VRMS Max.

Operating Temperature: +55°C (+131°F) Max.

**ORDERING INFORMATION:** Model 3957

### FEATURES:

- Converts BNC (Female) cables/connectors to top/side stackable banana plugs for test versatility.
- BNC connector and banana plugs are molded directly to the wire for pull strength durability and dust/moisture resistance.
- BNC dielectric is PTFE for superior temperature performance
- BNC center contact is gold plated for corrosion resistance, low contact resistance and long insertion life.

### MATERIALS:

BNC: Body - Brass, Nickel Plated

Center Contact – Brass, Gold Plated.

Dielectric: PTFE

All dimensions are in inches. Tolerances (except noted): .xx = ±.02" (.51 mm), .xxx = ±.005" (.127 mm).

All specifications are to the latest revisions. Specifications are subject to change without notice.

Registered trademarks are the property of their respective companies.

Made in USA

6/9/99

SY/EH/LS

S:\Engineering\Release\DataSheets\FI\ukeDataSheet\3957\_1\_01.doc

Sales: 800-490-2361 Fax: 888-403-3360

Technical Assistance: 800-241-2060

PomonaACCESS 90316 (800) 444-6785 or (425) 466-6010

More drawings available at [www.pomonaelectronics.com](http://www.pomonaelectronics.com)

Page 1 of 1