

# PRINTED CIRCUIT TRANSFORMERS

## “Side-Winder” SW/DSW Series

“Side-Winder”  
(SW)

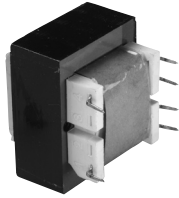

Dual “Side-Winder”  
(DSW)

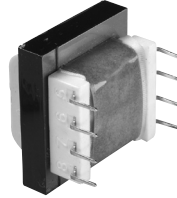

All Single Primaries are 115V 50/60Hz, 6 Pins  
All Dual Primaries are 115/230V 50/60Hz, 8 Pins

Sec.	STANCOR PART NUMBER	Primary Winding	AC/DC	Rated Output						VA	DIMENSIONS - INCHES							Weight (lbs.)	Agency * Certif.
				Individual Volts	Individual mA	Series Volts	Series mA	Parallel Volts	Parallel mA		H	W	L	MW	A	B	C		
A	SW-210	Single	AC	5.0	110	10.0 C.T.	110	5.0	220	1.1	0.94	1.13	1.38	-	0.25	0.25	1.20	0.17	UL/CSA
	DSW-210	Dual	AC	5.0	110	10.0 C.T.	110	5.0	220	1.1	0.94	1.13	1.38	-	0.25	0.25	1.20	0.17	UL/CSA
	SW-310	Single	AC	5.0	250	10.0 C.T.	250	5.0	500	2.5	1.19	1.13	1.38	-	0.25	0.25	1.20	0.25	UL/CSA
	DSW-310	Dual	AC	5.0	250	10.0 C.T.	250	5.0	500	2.5	1.19	1.13	1.38	-	0.25	0.25	1.20	0.25	UL/CSA
	SW-410	Single	AC	5.0	600	10.0 C.T.	600	5.0	1200	6.0	1.31	1.31	1.63	1.06	0.25	0.35	1.28	0.44	UL/CSA
	DSW-410	Dual	AC	5.0	600	10.0 C.T.	600	5.0	1200	6.0	1.31	1.31	1.63	1.06	0.25	0.35	1.28	0.44	UL/CSA
	SW-510	Single	AC	5.0	1200	10.0 C.T.	1200	5.0	2400	12.0	1.44	1.56	1.88	1.25	0.30	0.40	1.41	0.70	UL/CSA
	DSW-510	Dual	AC	5.0	1200	10.0 C.T.	1200	5.0	2400	12.0	1.44	1.56	1.88	1.25	0.30	0.40	1.41	0.70	UL/CSA
B	SW-212	Single	AC	6.3	90	12.6 C.T.	90	6.3	180	1.1	0.94	1.13	1.38	-	0.25	0.25	1.20	0.17	UL/CSA
	DSW-212	Dual	AC	6.3	90	12.6 C.T.	90	6.3	180	1.1	0.94	1.13	1.38	-	0.25	0.25	1.20	0.17	UL/CSA
	SW-312	Single	AC	6.3	200	12.6 C.T.	200	6.3	400	2.5	1.19	1.13	1.38	-	0.25	0.25	1.20	0.25	UL/CSA
	DSW-312	Dual	AC	6.3	200	12.6 C.T.	200	6.3	400	2.5	1.19	1.13	1.38	-	0.25	0.25	1.20	0.25	UL/CSA
	SW-412	Single	AC	6.3	500	12.6 C.T.	500	6.3	1000	6.0	1.31	1.31	1.63	1.06	0.25	0.35	1.28	0.44	UL/CSA
	DSW-412	Dual	AC	6.3	500	12.6 C.T.	500	6.3	1000	6.0	1.31	1.31	1.63	1.06	0.25	0.35	1.28	0.44	UL/CSA
	SW-512	Single	AC	6.3	1000	12.6 C.T.	1000	6.3	2000	12.0	1.44	1.56	1.88	1.25	0.30	0.40	1.41	0.70	UL/CSA
	DSW-512	Dual	AC	6.3	1000	12.6 C.T.	1000	6.3	2000	12.0	1.44	1.56	1.88	1.25	0.30	0.40	1.41	0.70	UL/CSA
C	SW-216	Single	AC	8.0	70	16.0 C.T.	70	8.0	140	1.1	0.94	1.13	1.38	-	0.25	0.25	1.20	0.17	UL/CSA
	SW-316	Single	AC	8.0	150	16.0 C.T.	150	8.0	300	2.5	1.19	1.13	1.38	-	0.25	0.25	1.20	0.25	UL/CSA
	DSW-316	Dual	AC	8.0	150	16.0 C.T.	150	8.0	300	2.5	1.19	1.13	1.38	-	0.25	0.25	1.20	0.25	UL/CSA
	SW-416	Single	AC	8.0	400	16.0 C.T.	400	8.0	800	6.0	1.31	1.31	1.63	1.06	0.25	0.35	1.28	0.44	UL/CSA
	DSW-416	Dual	AC	8.0	400	16.0 C.T.	400	8.0	800	6.0	1.31	1.31	1.63	1.06	0.25	0.35	1.28	0.44	UL/CSA
	SW-516	Single	AC	8.0	800	16.0 C.T.	800	8.0	1600	12.0	1.44	1.56	1.88	1.25	0.30	0.40	1.41	0.70	UL/CSA
	DSW-516	Dual	AC	8.0	800	16.0 C.T.	800	8.0	1600	12.0	1.44	1.56	1.88	1.25	0.30	0.40	1.41	0.70	UL/CSA
	SW-616	Single	AC	8.0	1250	16.0 C.T.	1250	8.0	2500	20.0	1.44	1.88	2.25	1.50	0.30	0.40	1.60	0.80	UL/CSA
DSW-616	Dual	AC	8.0	1250	16.0 C.T.	1250	8.0	2500	20.0	1.44	1.88	2.25	1.50	0.30	0.40	1.60	0.80	UL/CSA	
D	DSW-220	Dual	AC	10.0	55	20.0 C.T.	55	10.0	110	1.1	0.94	1.13	1.38	-	0.25	0.25	1.20	0.17	UL/CSA
	SW-320	Single	AC	10.0	120	20.0 C.T.	120	10.0	240	2.5	1.19	1.13	1.38	-	0.25	0.25	1.20	0.25	UL/CSA
	DSW-320	Dual	AC	10.0	120	20.0 C.T.	120	10.0	240	2.5	1.19	1.13	1.38	-	0.25	0.25	1.20	0.25	UL/CSA
	SW-420	Single	AC	10.0	300	20.0 C.T.	300	10.0	600	6.0	1.31	1.31	1.63	1.06	0.25	0.35	1.28	0.44	UL/CSA
	DSW-420	Dual	AC	10.0	300	20.0 C.T.	300	10.0	600	6.0	1.31	1.31	1.63	1.06	0.25	0.35	1.28	0.44	UL/CSA
	SW-520	Single	AC	10.0	600	20.0 C.T.	600	10.0	1200	12.0	1.44	1.56	1.88	1.25	0.30	0.40	1.41	0.70	UL/CSA
	DSW-520	Dual	AC	10.0	600	20.0 C.T.	600	10.0	1200	12.0	1.44	1.56	1.88	1.25	0.30	0.40	1.41	0.70	UL/CSA
	SW-620	Single	AC	10.0	1000	20.0 C.T.	1000	10.0	2000	20.0	1.44	1.88	2.25	1.50	0.30	0.40	1.60	0.80	UL/CSA
DSW-620	Dual	AC	10.0	1000	20.0 C.T.	1000	10.0	2000	20.0	1.44	1.88	2.25	1.50	0.30	0.40	1.60	0.80	UL/CSA	

\* Agency Certification Note:  UL Recognized (File E68100)  
1.1VA Size – UL Class 2 & 3 available  
 CSA Certified (File LR67965)

“Side-Winder” SW/DSW part numbers continued on page 28.  
For schematic diagrams and outline drawings refer to page 29.

# PRINTED CIRCUIT TRANSFORMERS

## “Side-Winder” SW/DSW Series

“Side-Winder”  
(SW)

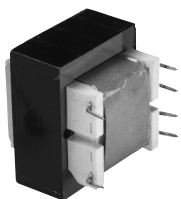

Dual “Side-Winder”  
(DSW)

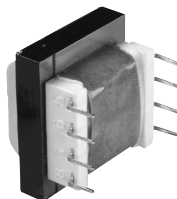

All Single Primaries are 115V 50/60Hz, 6 Pins  
All Dual Primaries are 115/230V 50/60Hz, 8 Pins

STANCOR PART Sec. NUMBER	Primary Winding	Rated Output								VA	DIMENSIONS - INCHES							Weight (lbs.)	Agency * Certif.
		AC/DC	Individual Volts	mA	Series Volts	mA	Parallel Volts	mA	H		W	L	MW	A	B	C			
A SW-224	Single	AC	12.0	45	24.0 C.T.	45	12.0	90	1.1	0.94	1.13	1.38	-	0.25	0.25	1.20	0.17	UL/CSA	
DSW-224	Dual	AC	12.0	45	24.0 C.T.	45	12.0	90	1.1	0.94	1.13	1.38	-	0.25	0.25	1.20	0.17	UL/CSA	
SW-324	Single	AC	12.0	100	24.0 C.T.	100	12.0	200	2.5	1.19	1.13	1.38	-	0.25	0.25	1.20	0.25	UL/CSA	
DSW-324	Dual	AC	12.0	100	24.0 C.T.	100	12.0	200	2.5	1.19	1.13	1.38	-	0.25	0.25	1.20	0.25	UL/CSA	
SW-424	Single	AC	12.0	250	24.0 C.T.	250	12.0	500	6.0	1.31	1.31	1.63	1.06	0.25	0.35	1.28	0.44	UL/CSA	
DSW-424	Dual	AC	12.0	250	24.0 C.T.	250	12.0	500	6.0	1.31	1.31	1.63	1.06	0.25	0.35	1.28	0.44	UL/CSA	
SW-524	Single	AC	12.0	500	24.0 C.T.	500	12.0	1000	12.0	1.44	1.56	1.88	1.25	0.30	0.40	1.41	0.70	UL/CSA	
DSW-524	Dual	AC	12.0	500	24.0 C.T.	500	12.0	1000	12.0	1.44	1.56	1.88	1.25	0.30	0.40	1.41	0.70	UL/CSA	
DSW-624	Dual	AC	12.0	800	24.0 C.T.	800	12.0	1600	20.0	1.44	1.88	2.25	1.50	0.30	0.40	1.60	0.80	UL/CSA	
B SW-228	Single	AC	14.0	40	28.0 C.T.	40	14.0	80	1.1	0.94	1.13	1.38	-	0.25	0.25	1.20	0.17	UL/CSA	
DSW-228	Dual	AC	14.0	40	28.0 C.T.	40	14.0	80	1.1	0.94	1.13	1.38	-	0.25	0.25	1.20	0.17	UL/CSA	
SW-328	Single	AC	14.0	85	28.0 C.T.	85	14.0	170	2.5	1.19	1.13	1.38	-	0.25	0.25	1.20	0.25	UL/CSA	
DSW-328	Dual	AC	14.0	85	28.0 C.T.	85	14.0	170	2.5	1.19	1.13	1.38	-	0.25	0.25	1.20	0.25	UL/CSA	
SW-428	Single	AC	14.0	200	28.0 C.T.	200	14.0	400	6.0	1.31	1.31	1.63	1.06	0.25	0.35	1.28	0.44	UL/CSA	
SW-528	Single	AC	14.0	420	28.0 C.T.	420	14.0	840	12.0	1.44	1.56	1.88	1.25	0.30	0.40	1.41	0.70	UL/CSA	
DSW-528	Dual	AC	14.0	420	28.0 C.T.	420	14.0	840	12.0	1.44	1.56	1.88	1.25	0.30	0.40	1.41	0.70	UL/CSA	
SW-628	Single	AC	14.0	700	28.0 C.T.	700	14.0	1400	20.0	1.44	1.88	2.25	1.50	0.30	0.40	1.60	0.80	UL/CSA	
DSW-628	Dual	AC	14.0	700	28.0 C.T.	700	14.0	1400	20.0	1.44	1.88	2.25	1.50	0.30	0.40	1.60	0.80	UL/CSA	
C SW-432	Single	AC	16.0	188	32.0 C.T.	188	16.0	376	6.0	1.31	1.31	1.63	1.06	0.25	0.35	1.28	0.44	UL/CSA	
DSW-432	Dual	AC	16.0	188	32.0 C.T.	188	16.0	376	6.0	1.31	1.31	1.63	1.06	0.25	0.35	1.28	0.44	UL/CSA	
D SW-236	Single	AC	18.0	30	36.0 C.T.	30	18.0	60	1.1	0.94	1.13	1.38	-	0.25	0.25	1.20	0.17	UL/CSA	
DSW-236	Dual	AC	18.0	30	36.0 C.T.	30	18.0	60	1.1	0.94	1.13	1.38	-	0.25	0.25	1.20	0.17	UL/CSA	
DSW-336	Dual	AC	18.0	65	36.0 C.T.	65	18.0	130	2.5	1.19	1.13	1.38	-	0.25	0.25	1.20	0.25	UL/CSA	
SW-436	Single	AC	18.0	170	36.0 C.T.	170	18.0	340	6.0	1.31	1.31	1.63	1.06	0.25	0.35	1.28	0.44	UL/CSA	
DSW-436	Dual	AC	18.0	170	36.0 C.T.	170	18.0	340	6.0	1.31	1.31	1.63	1.06	0.25	0.35	1.28	0.44	UL/CSA	
SW-536	Single	AC	18.0	350	36.0 C.T.	350	18.0	700	12.0	1.44	1.56	1.88	1.25	0.30	0.40	1.41	0.70	UL/CSA	
DSW-536	Dual	AC	18.0	350	36.0 C.T.	350	18.0	700	12.0	1.44	1.56	1.88	1.25	0.30	0.40	1.41	0.70	UL/CSA	
SW-636	Single	AC	18.0	550	36.0 C.T.	550	18.0	1100	20.0	1.44	1.88	2.25	1.50	0.30	0.40	1.60	0.80	UL/CSA	
DSW-636	Dual	AC	18.0	550	36.0 C.T.	550	18.0	1100	20.0	1.44	1.88	2.25	1.50	0.30	0.40	1.60	0.80	UL/CSA	
E SW-248	Single	AC	24.0	23	48.0 C.T.	23	24.0	46	1.1	0.94	1.13	1.38	-	0.25	0.25	1.20	0.17	UL/CSA	
DSW-248	Dual	AC	24.0	23	48.0 C.T.	23	24.0	46	1.1	0.94	1.13	1.38	-	0.25	0.25	1.20	0.17	UL/CSA	
DSW-348	Dual	AC	24.0	50	48.0 C.T.	50	24.0	100	2.5	1.19	1.13	1.38	-	0.25	0.25	1.20	0.25	UL/CSA	
DSW-448	Dual	AC	24.0	125	48.0 C.T.	125	24.0	250	6.0	1.31	1.31	1.63	1.06	0.25	0.35	1.28	0.44	UL/CSA	
SW-648	Single	AC	24.0	400	48.0 C.T.	400	24.0	800	20.0	1.44	1.88	2.25	1.50	0.30	0.40	1.60	0.80	UL/CSA	

\* Agency Certification Note:  UL Recognized (File E68100)  
1.1VA Size – UL Class 2 & 3 available  
 CSA Certified (File LR67965)

For schematic diagrams and outline drawings refer to page 29.

**"Side-Winder" SW Series**

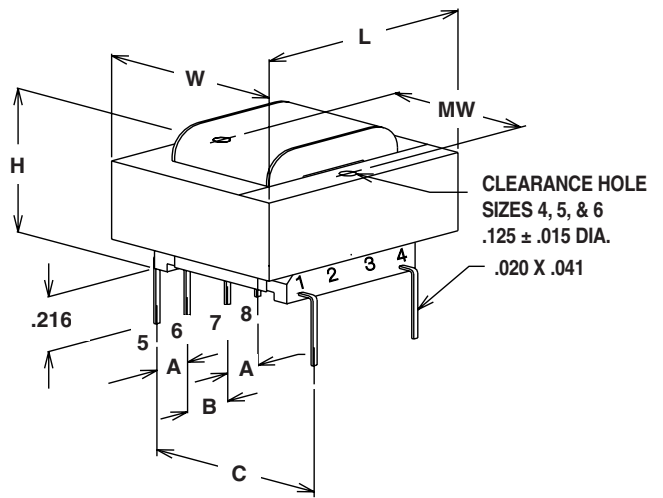
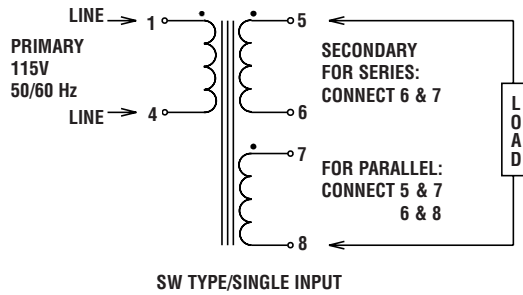

**"Side-Winder" DSW Series**

