

CVS Hardwired Series – Constant Voltage Transformers

Superior voltage regulation of $\pm 1\%$ sets the CVS series apart from other power conditioning technologies on the market. Extremely tight regulation is accomplished by SolaHD's ferroresonant transformer technology. The CVS recreates a well regulated sinusoidal waveform that is well isolated from input disturbances including:

- Impulses
- Swells
- Brownouts
- Sags
- Severe waveform distortion

No other power conditioning technology provides as complete a solution against these power quality disturbances. The CVS series is ideal for applications where even a small change in voltage level can lead to unscheduled downtime, misoperation, incorrect data or scrapped production.

Features

- Superior voltage regulation of $\pm 1\%$
- Surge protection tested to ANSI/IEEE C62.41, Class A & B Waveform
- Harmonic filtering
- Hardwired
- Acts as a Step-up/Step-down Transformer
- Galvanic isolation provides exceptional circuit protection.
- 25 year typical Mean Time Between Failure
- No maintenance required



Applications

- Industrial automation and control equipment PLCs
- Analytical laboratory and factory automating equipment
- Photo processing equipment
- Sound/recording systems
- Photographic enlargers
- Broadcast equipment

Related Products

- On-line UPS (S4K Industrial)
- Surge Protection
- Three Phase Power Conditioners
- Active Tracking® Filters

Selection Tables: Single Phase

Group 1 – CVS Series, 60 Hz

VA	Catalog Number	Voltage Input	Voltage Output	Height (inch)	Width (inch)	Depth (inch)	Ship Weight (lbs)	Design Style	Elec Conn
30	23-13-030-2	120	120	7	4	5	9	1	J
60	23-13-060-2	120	120	7	4	5	9	1	J
120	23-22-112-2	120, 240	120	8	4	5	13	1	J
250	23-23-125-8	120, 240, 480	120	11	6	8	29	1	G
500	23-23-150-8	120, 208, 240, 480	120, 240	13	9	7	42	1	H
1000	23-23-210-8	120, 208, 240, 480	120, 240	17	9	7	65	1	H
2000	23-23-220-8	120, 208, 240, 480	120, 240	18	13	10	111	1	H
3000	23-23-230-8	120, 208, 240, 480	120, 240	19	13	10	142	1	H
5000	23-23-250-8	120, 208, 240, 480	120, 240	28	13	10	222	1	H
7500*	23-28-275-6	240, 480	120, 240	27	25	9	365	2	J

* This unit is not CSA Certified.

Contact **Technical Services** at (800) 377-4384 with any questions.
Visit our website at www.solahd.com.

Specifications

Parameter	Condition	Value
Input		
Voltage	Continuous at full load (lower input voltage possible at lighter load)	+10% to -20% of nominal
	For temporary surge or sags	+20% to -35% of nominal
Current¹	at Full Load & 80% of nominal input voltage	$I_n \cong (VA/.87)/(V_{in} \times 80\%)$
Frequency	See Operating Characteristics section for details.	60 Hz
Output		
Line Regulation	$V_{in} >80\%$ and $<110\%$ of nominal	$\pm 1\%$
Overload Protection	At Nominal Input Voltage	Current limited at 1.65 times rated current
Output Harmonic Distortion	At Full Load within Input Range	3% total RMS content
Noise Attenuation	-Common Mode	40 dB
	-Transverse Mode	40 dB
General		
Efficiency	At Full Load	Up to 92%
Storage Temperature	Humidity $<95\%$ non-condensing	-20° to 80°C
Operating Temperature	Humidity $<95\%$ non-condensing	-20° to 50°C
Audible Noise	Full Resistive Noise	32 dBA to 65 dBA
Approvals	60 Hz Models	UL1012, CSA ²
Warranty	See General Information section for details	10 Years

Notes:

- 1 - Consult user manual for fuse sizing.
- 2 - Applies to all models except 23-28-275-6.
- 3 - It is recommended that the unit run at a minimum of 40-50% load.
See the Operating Characteristics section of this chapter for more information.

Design Styles (CVS and MCR Hardwired)

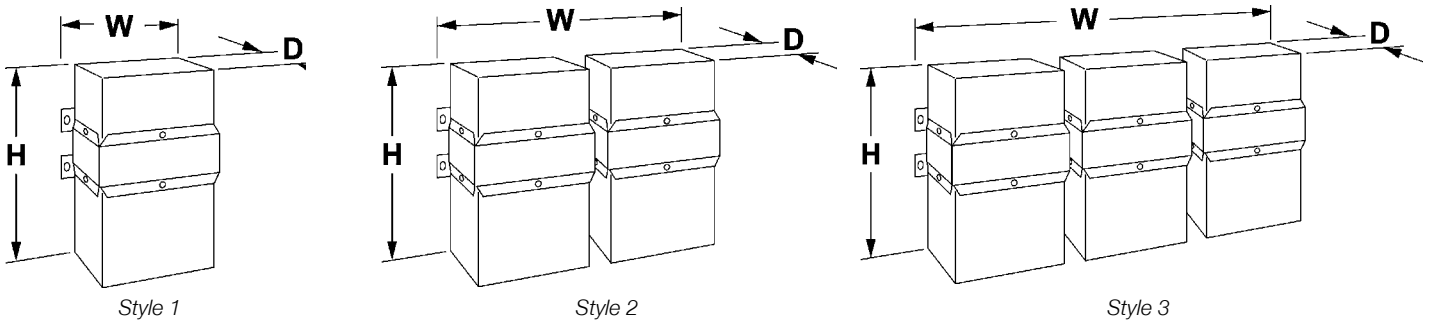

These styles are single phase only.

Contact **Technical Services** at (800) 377-4384 with any questions.
Visit our website at www.solahd.com.