



ETA-USA

300W/450W

High Quality Switching Power Supplies

85-264VAC

Power - Factor Correction

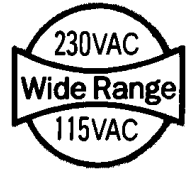

300W FHF-SX SERIES

450W FHP-SX-U SERIES

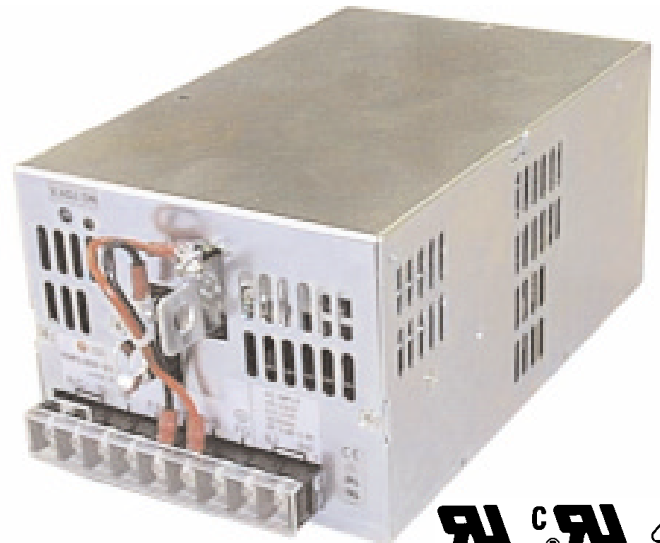
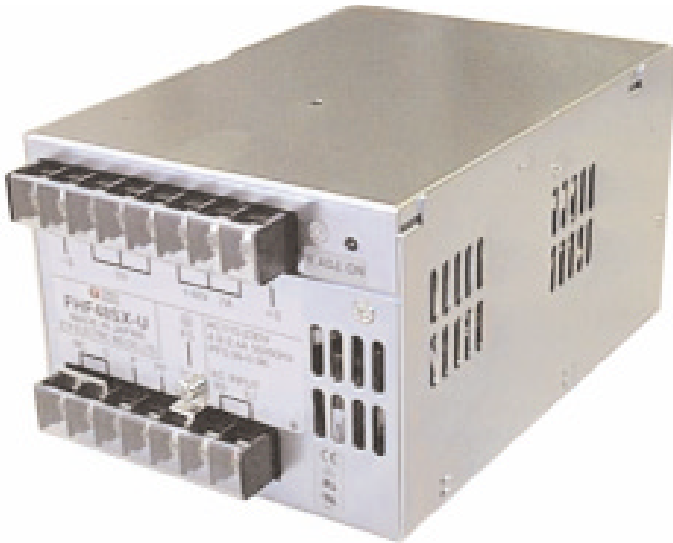

Output Table

FHF-SX (AC85~264V) 120X170X93 (mm)

MODEL	OUTPUT		EFFICIENCY
	VOLTAGE	CURRENT	
FHF 3.3SX	3.3V	60A	67%
FHF 05SX	5V	60A	72%
FHF 06SX	6V	50A	73%
FHF 12SX	12V	27A	75%
FHF 15SX	15V	22A	76%
FHF 24SX	24V	14A	78%
FHF 30SX	30V	11A	78%
FHF 36SX	36V	9A	78%
FHF 48SX	48V	7A	80%

Output Table

FHP-SX-U (AC85~264V) 120X190X93 (mm)

MODEL	OUTPUT		EFFICIENCY
	VOLTAGE	CURRENT	
FHP 3.3SX-U	3.3V	90A	68%
FHP 05SX-U	5V	90A	70%
FHP 06SX-U	6V	75A	71%
FHP 12SX-U	12V	40A	75%
FHP 15SX-U	15V	32A	78%
FHP 24SX-U	24V	20A	79%
FHP 30SX-U	30V	16A	77%
FHP 36SX-U	36V	13A	79%
FHP 48SX-U	48V	10A	80%

FHF/P Series are a new generation of powersupplies. Its the latest design following the international standards and market demands. This type of powersupply has all in one : Power factor correction, low line distortion according to EN 60555-2, electro magnetic Interference (EMI) complies to VDE 0871/13, EN 55022/13, FCC level B. Safety is complying to VDE/EN 60950, UL 1950, CSA 234. The size is compatible with WR Series. High efficiency and power factor correction is an optimal combination of good cost-performance for both, end-user and power production companies.

Special Features

1. Power factor 115Vac=0.99 230Vac=0.96 (FHF-SX)
115Vac=0.98 230Vac=0.92 (FHP-SX-U)
2. Harmonics acc. to EN 60555-2 IEC 1000-3-2
3. EMI : complies with FCC class B VDE class B (FHF-SX) /EN55022 class B(FHP-SX-U)
4. approved:UL1950, EN60950, VDE0805, CSA234 (C-UL) (FHF-SX pending)
5. CE marked to the low voltage directive (FHF-SX pending)

Applications

Process control, Office-Equipment, Computer Peripherals, Telecommunication, Industrial Electronics and Machines, Household-Equipment

Dimension (mm)

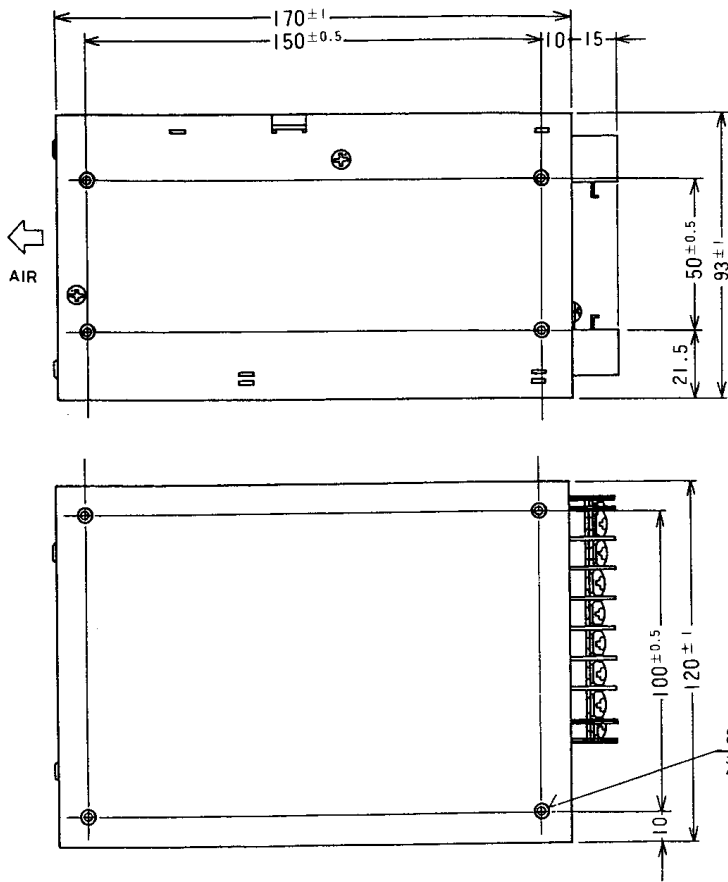

FHF-SX SERIES

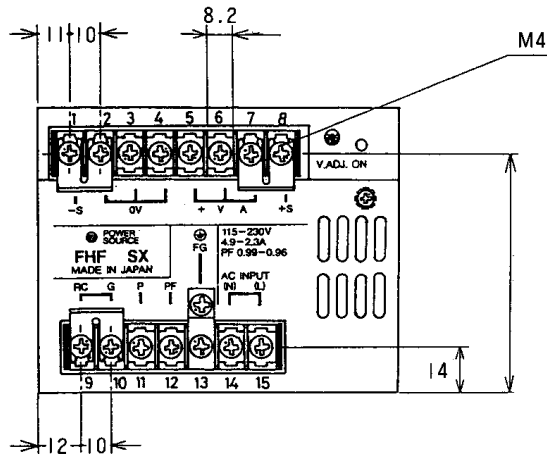

Terminal Connection

端子番号 terminal No.	接 続 connection	端子番号 terminal No.	接 続 connection
1	- Remote sensing	9	Remote control
2	Ground	10	Remote control ground
3	Ground	11	Parallel
4	Ground	12	Power fail
5	+ V	13	Frame ground
6	+ V	14	AC-neutral
7	+ V	15	AC-line
8	+ Remote sensing		

Dimension (mm)

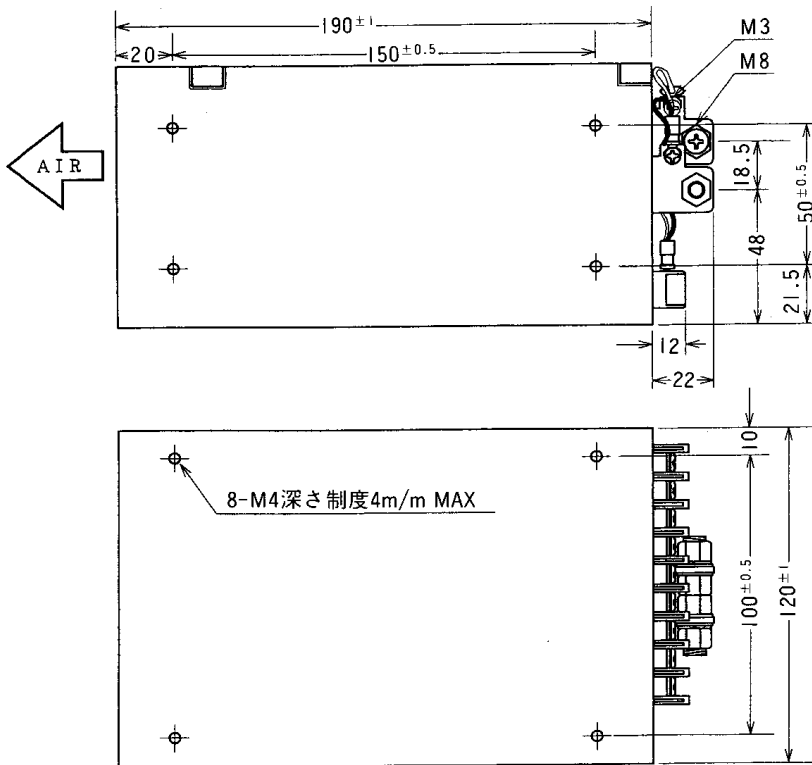

FHF-SX SERIES

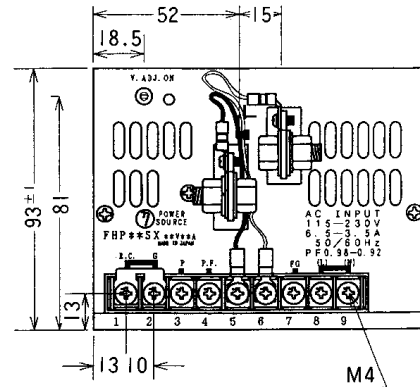

Terminal Connection

端子番号 terminal No.	接 続 connection
1	Remote control
2	Remote control ground
3	Parallel
4	Power fail
5	- Remote sensing
6	+ Remote sensing
7	Frame ground
8	AC-line
9	AC-neutral

* Terminal cover is attached

300W FHF-SX SERIES

450W FHP-SX-U SERIES

STANDARD SPECIFICATION

INPUT

Voltage nominal	:AC115~230V (Wide range)
Voltage range	:85~264VAC
Power factor & harmonic correction range	:85~255VAC
Frequency	:50/60Hz
Current on full road	:4.9A/2.3A(Input 115VAC/230VAC) FHF-SX
	:6.5A/3.5A(Input 115VAC/230VAC) FHF-SX
Inrush current	:12A/24A MAX(Input 115VAC/230VAC) FHF-SX
	:10A/20A MAX(Input 115VAC/230VAC)FHP-SX
Phase	:Single

OUTPUT

Adjustable voltage	:± 10%, (+10,-20%(FHF3.3SX only)
Ripple & noise	:(Output V x 1%)+100mVp-p MAX(1)
Input regulation	:0.5%MAX
Load regulation	:1.0%MAX
Temperature coefficient	:0.03% / °C(-5~50°C)
Drift / Time effect	:(Output V X 0.5%)+15mV/8H (After 1 H)
Rise up time	:300mS/150mS(Input 115V/230VAC) FHF-SX
	:500mS/200mS(Input 115V/230VAC) FHF-SX
Hold-up time	:60mSTyp(FHF-SX), 20mSTyp (FHP-SX)

FUNCTIONS

Remote sensing is possible

Remove attached ± short piece and connect with load by using twist pair wire. While doing above, voltage drop shall be less than 0.3V (one line 0.15V).

Remote control

Output normal by short or L (0~0.4V) Output shutdown by open or H (1~6V) Input current shall be less than 0.1 (A) while

Series and parallel operation is possible

-Parallel operation Connect P terminals to each ether rated current of parallel is

$$\left(\begin{array}{c} \text{Rated current} \\ \text{of parallel} \end{array} \right) = \left(\begin{array}{c} \text{Rated current} \\ \text{of one power source} \end{array} \right) \times \frac{\text{number of}}{\text{power source}} \times 0.9$$

-The voltage agrees with lower one.

-Operate with number of power source four or less Power fail Please refer about P.F to our Sales Dep.

GENERAL SPECIFICATION

Power factor correction	:Active filter circuit with booster
Over-current protection	:Automatic reset
Over-voltage protection	:Output shutdown
Remote control	:Possible
Remote sensing	:Possible
Switching frequency	:Possible
Withstand voltage	:130KHz
	:(Input-Output) :AC3000V(1Minute)
	:(Input-Chassis) :AC2500V (1Minute)
	:(Output-Chassis) :AC 500V (1Minute)
Insulation resistance	:(Input-Output-Chassis):50M MIN.
Leakage current	:1mAMAX(Input 115VAC/230VAC) FHF-SX
	:0.24mATyp/0.6mATyp(Input 115VAC/230VAC)FHP-SX
Weight	:1.9kg(FHF-SX), 2.1kg(FHP-SX)

ENVIRONMENT

Operating temperature	:-5 ~+50°C (2)
	:-20~+85°C
Storage temperature	:10~85%
Humidity	:(5~10Hz) Amplitude (peak to peak)
Vibration	10mm(constant) (10~55Hz) Acceleraton 2G (3)
Shock	:30G (3)

OUTPUT DERATING

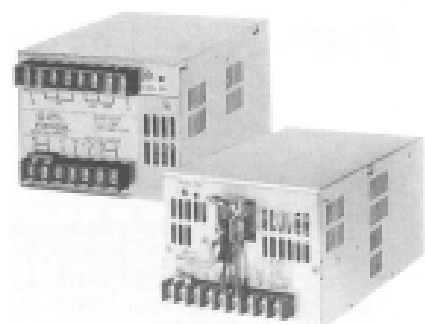
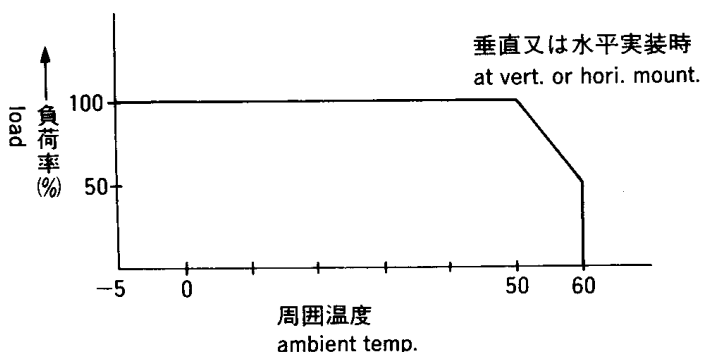

*安全規格取得条件については、都度ご確認ください。
for further information contact safety approvals.

FHF-SX SERIES (300W)

Load & Output V.

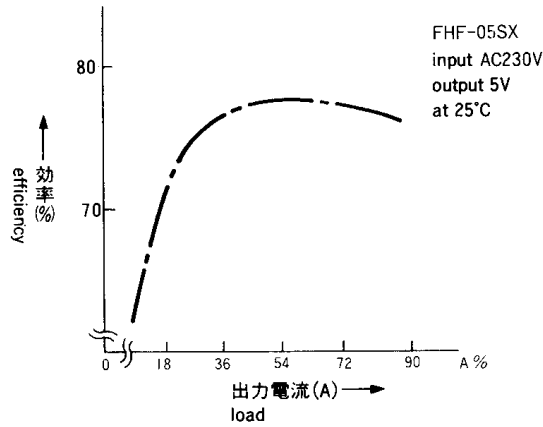
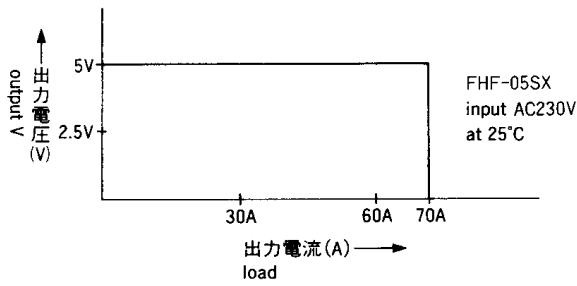

FHP-SX SERIES (450W)

Load & Output V.

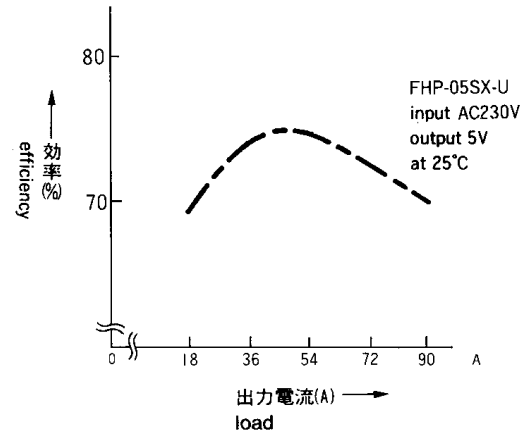
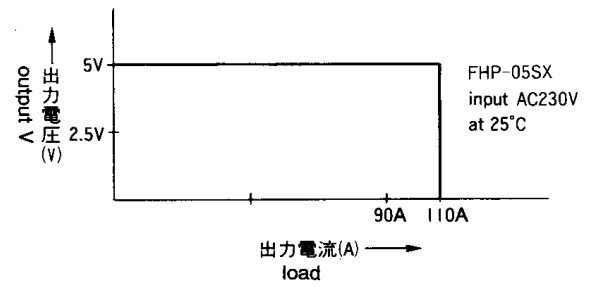

Block Diagram

FHF-SX
FHP-SX

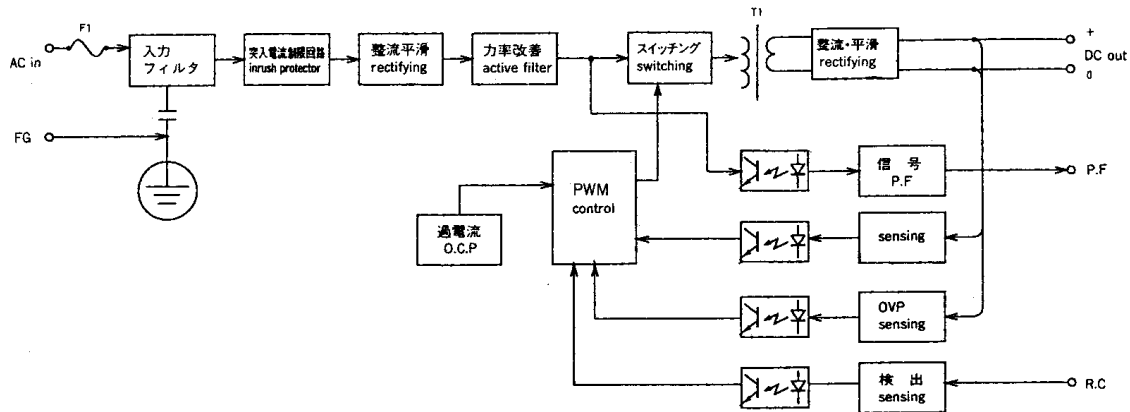

ETA-USA

16315 Vineyard Blvd. Morgan Hill, CA 95037

Phone: 1-800-ETA-POWER (408) 778-2793 Fax: (408) 779-2753

Visit Us On The Web at:

<http://www.eta-usa.com/>

Or Email at:

sales@eta-usa.com