



ETA-USA

HIGH QUALITY SWITCHING POWER SUPPLIES

DC/DC SWITCHING POWER SUPPLY
DC INPUT 12,24,48, 110
SINGLE OUTPUT
150WATTS

VTE-SCx/VTE-SD SERIES



Dimension: 70W × 200L × 97H

General Description

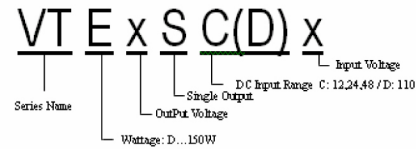

Features

1. Variety of Models
2. Chassis mount type
3. Compact and High Efficiency

DC INPUT: 12V

Input Characteristics	Unit	VTE05SC12	VTE12SC12	VTE15SC12	VTE24SC12	VTE48SC12
Input Voltage	Vdc	DC 12V				
Input Voltage Range	Vdc	DC 9.2V-16V				
Input Current (typ)	A	14.42	16.05	14.88	15.66	16.30
Inrush Current *1	A	Not Specified				
Efficiency (typical) *2	%	78	81	82	84	83
MTBF	H	420'000				
Switching Frequency	kHz	67 Fix.	67 Fix.	67 Fix.	67 Fix.	67 Fix.

DC INPUT: 24V

Input Characteristics	Unit	VTE05SC24	VTE12SC24	VTE15SC24	VTE24SC24	VTE48SC24
Input Voltage	Vdc	DC 24V				
Input Voltage Range	Vdc	DC 19-32V				
Input Current (typ)	A	7.91	8.75	8.38	8.64	8.86
Inrush Current *1	A	Not Specified				
Efficiency (typical) *2	%	81	85	87	89	89
MTBF	H	420'000				
Switching Frequency	kHz	67 Fix.	67 Fix.	67 Fix.	67 Fix.	67 Fix.

DC INPUT: 48V

Input Characteristics	Unit	VTE05SC48	VTE12SC48	VTE15SC48	VTE24SC48	VTE48SC48
Input Voltage	Vdc	DC 48V				
Input Voltage Range	Vdc	DC 38-63V				
Input Current (typ)	A	4.01	4.27	4.14	4.17	4.07
Inrush Current *1	A	Not Specified				
Efficiency (typical) *2	%	83	86	87	89	91
MTBF	H	430'000				
Switching Frequency	kHz	70 Fix.	70 Fix.	70 Fix.	70 Fix.	70 Fix.

DC INPUT: 110V

Input Characteristics	Unit	VTE05SD	VTE12SD	VTE15SD	VTE24SD	VTE48SD
Input Voltage	Vdc	DC 110V				
Input Voltage Range	Vdc	DC 85-140V				
Input Current (typ)	A	1.68	1.82	1.74	1.76	2.08
Inrush Current *1	A	20				
Efficiency (typical) *2	%	81	84	86	87	88
MTBF	H	400'000				
Switching Frequency	kHz	120 Fix.	120 Fix.	120 Fix.	120 Fix.	120 Fix.



ETA USA
16170 Vineyard Blvd. Suite 180, Morgan Hill, CA 95037
Phone: 1-800-ETA-POWER, (408) 778-2793 Fax: (408) 779-2753

Visit us at: www.eta-usa.com
email at: sales@eta-usa.com



ETA-USA

HIGH QUALITY SWITCHING POWER SUPPLIES

VTD-SC / VTD-SD

Output Characteristic	Unit	Models				
		VTE05SCx / SD	VTE12SCx / SD	VTE15SCx / SD	VTE24SCx / SD	VTE48SCx / SD
Output Voltage	V	5	12	15	24	48
Output Current Vin:12VDC Vin: 24,48 VDC Vin: 110 VDC	A	27	13	10	6.5	3.3
	A	30	14	11	7.0	3.5
	A	30	14	11	7.0	4.2
Voltage Adjust Range	V	+/-10% of Rated Output Voltage(at no load within input range)				
Ripple Noise(max) *3	mVpp	100	170	200	290	530
Rise up time	mS	200mS(maximum) at 25°C and rated input/output (Vin: 110 500mS)				
Hold up time	mS	Not specified (Vin: 110 10mS(typical) at 25°C and rated input/output)				
Regulation						
a. Line Regulation (max)	mV	25 (Vin=110 40)	60 (Vin=110 96)	75 (Vin=110 120)	120 (Vin=110 192)	240 (Vin=110 384)
b. Load Regulation (max)	mV	30 (Vin=110 45)	72 Vin=110 108)	90 (Vin=110 135)	144 (Vin=110 216)	288 (Vin=110 432)
c. Temperature Coefficient *4	°C	0.01%/°C (Vin=110 0.03%/°C)				
d. Drift(maximum) *5	mV	40	75	90	135	255
e. Dynamic Load Regulation (typ.) *6	mV	150 (Vin=24,48 100)	360 (Vin=24,48 120)	450 (Vin=24,48 300)	720 (Vin=24,48 480)	1440 (Vin=24,48 960)
f. Recovery Time *6	mS	0.5mS				

Conditions:

*1 at cold start

*2 at rated input/output

*3 measured by a bayonet probe at the output connector at a 0 to 100MHz bandwidth

*4 at 0 to +50°C

*5 for 7hour period after 1hour warm-up at 25°C and rated input/output

*6 when output current changed between 25% and 75% of rated output current rapidly at rated input

Environmental Specification	
Operating Temperature	0 to +50°C
Operating Humidity	85%RH (non-condensing)
Storage Temperature	-20 to +85°C
Storage Humidity	-
Withstanding Voltage	Primary-Secondary AC1,500Vfor 1minute (Vin=110 2000) Primary-Frame Ground AC1,500V for 1minute (Vin=110 2000) Secondary-Frame Ground AC500V for 1minute
Isolation Resistance	Primary-Secondary-Frame Ground 50MΩ(minimum) by DC500V insulation tester
Vibration	5-10Hz:10mm double amplitude,10-55Hz:19.6m/s ² ,20minutes' period for 60minutes each along X,Y,Z axes(non-operating)
Shock	294m/s ²
Cooling	Convection

Functions	
Over current Protection	Current Limiting with automatic recovery
Over voltage Protection	Output shutdown
Remote Sense	not available
Remote On/Off	not available
Reverse Voltage Protection	not available (Vin=110 by internal bridge diode)
Line Conduction Noise	Not specified
Weight [g] (typical)	1.4 kg
Dimension [mm]	70W × 200L × 97H



ETA USA

16170 Vineyard Blvd. Suite 180, Morgan Hill, CA 95037

Phone: 1-800-ETA-POWER, (408) 778-2793 Fax: (408) 779-2753

Visit us at: www.eta-usa.com

email at: sales@eta-usa.com



ETA-USA

HIGH QUALITY SWITCHING POWER SUPPLIES

BLOCK DIAGRAM

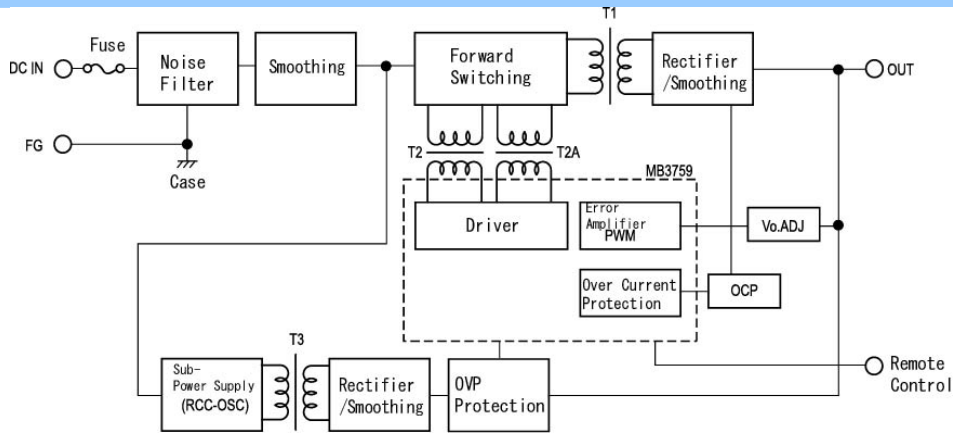

DIMENSION DIAGRAM (mm)

- Pin Assignments
- 1 +V out
 - 2 +V out
 - 3 +S
 - 4 -S
 - 5 0V out
 - 6 0V out
 - 7 RC
 - 8 DC in +V
 - 9 DC in 0V
 - 10 FG

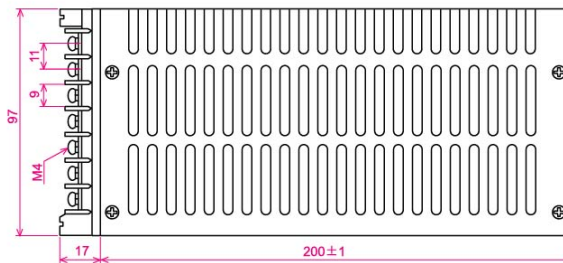
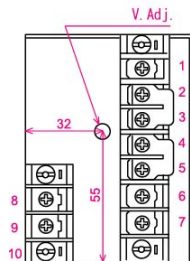
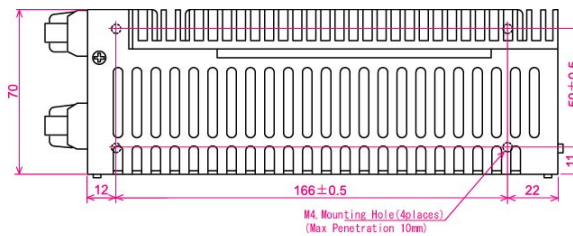

EFFICIENCY CURVE

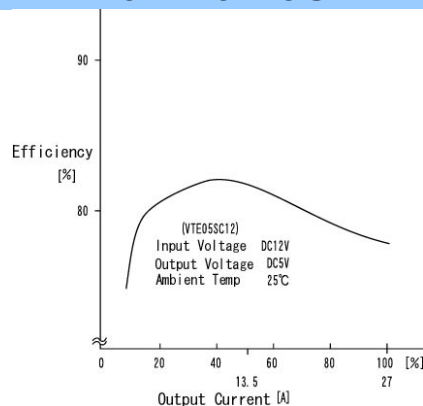

ETA USA
16170 Vineyard Blvd. Suite 180, Morgan Hill, CA 95037
Phone: 1-800-ETA-POWER, (408) 778-2793 Fax: (408) 779-2753

Visit us at: www.eta-usa.com
email at: sales@eta-usa.com