



120W Single Output Industrial DIN RAIL Power Supply

DRH-120 series



■ Features :

- Protections: Short circuit / Overload / Over voltage / Over temperature
- Cooling by free air convection
- Built-in constant current limiting circuit
- Can be installed on DIN rail TS-35/7.5 or 15
- EN61000-6-2(EN50082-2) industrial immunity level
- 100% full load burn-in test
- Fixed switching frequency at 70KHz
- 3 years warranty



SPECIFICATION

MODEL	DRH-120-24	DRH-120-48	
OUTPUT	DC VOLTAGE	24V	48V
	RATED CURRENT	5A	2.5A
	CURRENT RANGE	0 ~ 5A	0 ~ 2.5A
	RATED POWER	120W	120W
	RIPPLE & NOISE (max.) Note.2	80mVp-p	80mVp-p
	VOLTAGE ADJ. RANGE	24 ~ 28V	48 ~ 55V
	VOLTAGE TOLERANCE Note.3	±1.0%	±1.0%
	LINE REGULATION	±0.5%	±0.5%
LOAD REGULATION	±0.5%	±0.5%	
SETUP, RISE, HOLD UP TIME	1700ms, 120ms, 16ms/400VAC 1000ms, 120ms, 30ms/500VAC at full load		
INPUT	VOLTAGE RANGE	340 ~ 550VAC 480 ~ 780VDC	
	FREQUENCY RANGE	47 ~ 63Hz	
	EFFICIENCY (Typ.)	85%	86%
	AC CURRENT	0.65A/400VAC 0.6A/500VAC	
	INRUSH CURRENT (max.)	COLD START 50A	
LEAKAGE CURRENT	<3.5mA / 530VAC		
PROTECTION	OVERLOAD	105 ~ 160% rated output power Protection type : Constant current limiting, recovers automatically after fault condition is removed	
	OVER VOLTAGE	30 ~ 36V	59 ~ 66V
	OVER TEMPERATURE	85°C ±5°C (TSW) detect on heatsink of power switch Protection type : Shut down o/p voltage, recovers automatically after temperature goes down	
ENVIRONMENT	WORKING TEMP.	-20 ~ +60°C (Refer to output load derating curve)	
	WORKING HUMIDITY	20 ~ 90% RH non-condensing	
	STORAGE TEMP., HUMIDITY	-40 ~ +85°C, 10 ~ 95% RH	
	TEMP. COEFFICIENT	±0.03%/°C (0 ~ 50°C)	
SAFETY & EMC (Note 4)	VIBRATION	Component: 10 ~ 500Hz, 2G 10min./1cycle, 60min. each along X, Y, Z axes; Mounting clip: Compliance to IEC60068-2-6	
	SAFETY STANDARDS	UL60950-1 approved, IEC60950-1 CB approved by SIQ	
	WITHSTAND VOLTAGE	I/P-O/P:3KVAC I/P-FG:1.5KVAC O/P-FG:0.5KVAC	
	ISOLATION RESISTANCE	I/P-O/P, I/P-FG, O/P-FG:100M Ohms / 500VDC / 25°C / 70% RH	
	EMI CONDUCTION & RADIATION	Compliance to EN55011 (CISPR11), EN55022 (CISPR22), EN61204-3 Class B	
OTHERS	EMS IMMUNITY	Compliance to EN61000-4-2,3,4,5,6,8,11, ENV50204, EN61204-3, EN61000-6-2 (EN50082-2), heavy industry level, criteria A	
	MTBF	178.7Khrs min. MIL-HDBK-217F (25°C)	
	DIMENSION	65.5*125.2*100mm (W*H*D)	
NOTE	PACKING	0.75Kg; 20pcs/16Kg/1.29CUFT	
		1. All parameters NOT specially mentioned are measured at 400VAC input, rated load and 25°C of ambient temperature. 2. Ripple & noise are measured at 20MHz of bandwidth by using a 12" twisted pair-wire terminated with a 0.1uF & 47uF parallel capacitor. 3. Tolerance : includes set up tolerance, line regulation and load regulation. 4. The power supply is considered a component which will be installed into a final equipment. The final equipment must be re-confirmed that it still meets EMC directives.	

Mechanical Specification

Case No.921A Unit:mm

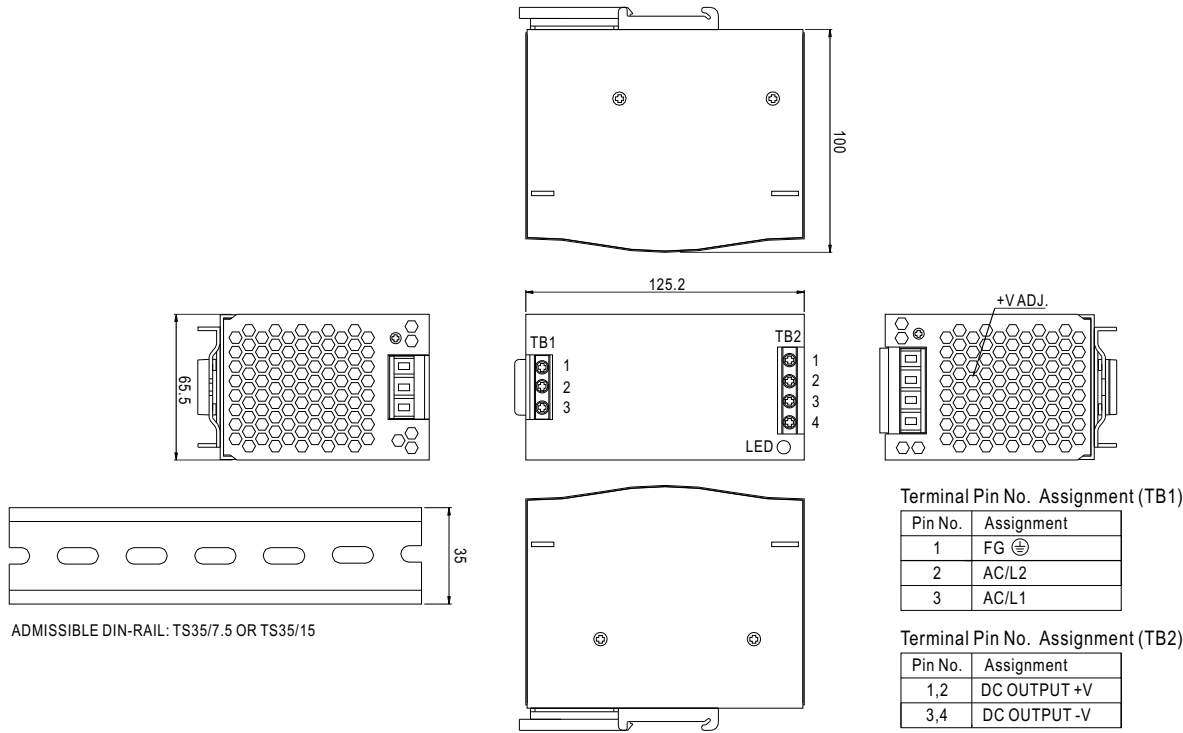

Block Diagram

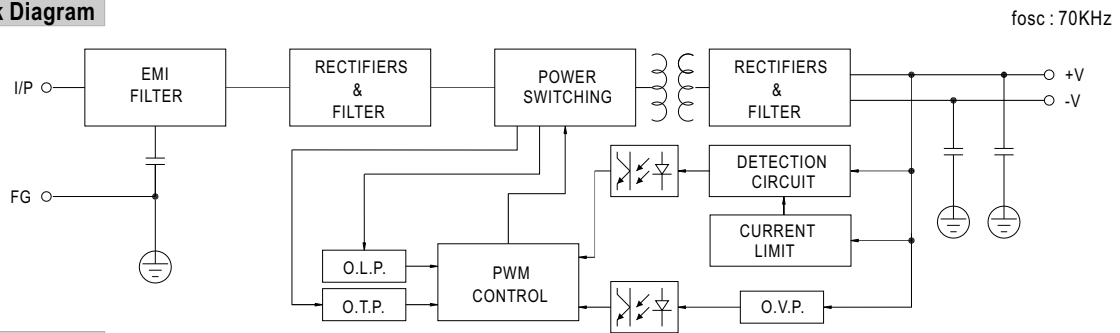

Derating Curve

