



- Features :
- AC input range selected by switch
- Protections: Short circuit / Overload / Over voltage
- Forced air cooling by built-in DC fan
- 100% full load burn-in test
- Fixed switching frequency at 75KHz
- Low cost
- High reliability
- 2 years warranty



SPECIFICATION

MODEL		Q-250B				Q-250C				
OUTPUT	DC VOLTAGE	+5V	+12V	-12V	-5V	+5V	+15V	-15V	-5V	
	RATED CURRENT	20A	7A	1A	1A	20A	5A	1A	1A	
	CURRENT RANGE	2 ~ 20A	0.5 ~ 7A	0.5 ~ 1A	0 ~ 1A	2 ~ 20A	0.5 ~ 5A	0.5 ~ 1A	0 ~ 1A	
	RATED POWER	201W				195W				
	RIPPLE & NOISE (max.) Note.2	80mVp-p	120mVp-p	120mVp-p	50mVp-p	80mVp-p	150mVp-p	150mVp-p	50mVp-p	
	VOLTAGE ADJ. RANGE	4.75 ~ 5.5V				4.75 ~ 5.5V				
	VOLTAGE TOLERANCE Note.3	2.0%	+8, -10%	10%	6.0%	2.0%	10%	10%	6.0%	
	LINE REGULATION	0.5%	1.0%	1.0%	1.0%	0.5%	1.0%	1.0%	1.0%	
	LOAD REGULATION	1.0%	6.0%	8.0%	2.0%	1.0%	8.0%	10%	2.0%	
SETUP, RISE, HOLD UP TIME	800ms, 50ms, 20ms at full load									
INPUT	VOLTAGE RANGE	90 ~ 132VAC / 176 ~ 264VAC Selected by switch				248 ~ 370VDC				
	FREQUENCY RANGE	47 ~ 63Hz								
	EFFICIENCY (Typ.)	73%				74%				
	AC CURRENT	6A/115VAC		3.5A/230VAC						
	INRUSH CURRENT (max.)	COLD START 50A								
	LEAKAGE CURRENT	<2mA / 240VAC								
PROTECTION	OVERLOAD	105 ~ 150% rated output power Protection type : Hiccup mode, recovers automatically after fault condition is removed								
	OVER VOLTAGE	+5V: 5.75 ~ 6.75V Protection type : Hiccup mode, recovers automatically after fault condition is removed								
ENVIRONMENT	WORKING TEMP.	-10 ~ +60°C (Refer to output load derating curve)								
	WORKING HUMIDITY	20 ~ 90% RH non-condensing								
	STORAGE TEMP., HUMIDITY	-20 ~ +85°C, 10 ~ 95% RH								
	TEMP. COEFFICIENT	0.03%/°C (0 ~ 50°C)								
	VIBRATION	10 ~ 500Hz, 2G 10min./1cycle, 60min. each along X, Y, Z axes								
SAFETY & EMC	SAFETY STANDARDS	UL60950-1 approved								
	WITHSTAND VOLTAGE	I/P-O/P:3KVAC		I/P-FG:1.5KVAC		O/P-FG:0.5KVAC				
	ISOLATION RESISTANCE	I/P-O/P, I/P-FG, O/P-FG:100M Ohms/500VDC								
OTHERS	MTBF	219.5K hrs min. MIL-HDBK-217F (25°C)								
	DIMENSION	150*140*86mm (L*W*H)								
	PACKING	1.4Kg; 8pcs/11.5Kg/0.97CUFT								
NOTE	<p>1. All parameters NOT specially mentioned are measured at 230VAC input, rated load and 25°C of ambient temperature.</p> <p>2. Ripple & noise are measured at 20MHz of bandwidth by using a 12" twisted pair-wire terminated with a 0.1uf & 47uf parallel capacitor.</p> <p>3. Tolerance : includes set up tolerance, line regulation and load regulation.</p>									



- Features :
- AC input range selected by switch
- Protections: Short circuit / Overload / Over voltage
- Forced air cooling by built-in DC fan
- 100% full load burn-in test
- Fixed switching frequency at 75KHz
- Low cost
- High reliability
- 2 years warranty



SPECIFICATION

MODEL		Q-250D				Q-250F				
OUTPUT	DC VOLTAGE	+5V	+12V	+24V	-12V	+5V	+15V	+24V	-15V	
	RATED CURRENT	10A	5A	5A	1A	10A	4A	5A	1A	
	CURRENT RANGE	2 ~ 15A	0.5 ~ 6A	0.5 ~ 5A	0 ~ 1A	2 ~ 15A	0.5 ~ 5A	0.5 ~ 5A	0 ~ 1A	
	RATED POWER	242W				245W				
	RIPPLE & NOISE (max.) Note.2	80mVp-p	120mVp-p	240mVp-p	120mVp-p	80mVp-p	150mVp-p	240mVp-p	150mVp-p	
	VOLTAGE ADJ. RANGE	4.75 ~ 5.5V				4.75 ~ 5.5V				
	VOLTAGE TOLERANCE Note.3	2.0%	+6, -10%	8.0%	6.0%	2.0%	+6, -10%	8.0%	6.0%	
	LINE REGULATION	0.5%	1.0%	1.0%	1.0%	0.5%	1.0%	1.0%	1.0%	
	LOAD REGULATION	1.0%	5.0%	6.0%	2.0%	1.0%	4.0%	6.0%	2.0%	
SETUP, RISE, HOLD UP TIME	800ms, 50ms, 16ms at full load									
INPUT	VOLTAGE RANGE	90 ~ 132VAC / 176 ~ 264VAC Selected by switch				248 ~ 370VDC				
	FREQUENCY RANGE	47 ~ 63Hz								
	EFFICIENCY (Typ.)	78%				78%				
	AC CURRENT	6A/115VAC		3.5A/230VAC						
	INRUSH CURRENT (max.)	COLD START 50A								
	LEAKAGE CURRENT	<2mA / 240VAC								
PROTECTION	OVERLOAD	105 ~ 150% rated output power Protection type : Hiccup mode, recovers automatically after fault condition is removed								
	OVER VOLTAGE	+5V: 5.75 ~ 6.75V Protection type : Hiccup mode, recovers automatically after fault condition is removed								
ENVIRONMENT	WORKING TEMP.	-10 ~ +60°C (Refer to output load derating curve)								
	WORKING HUMIDITY	20 ~ 90% RH non-condensing								
	STORAGE TEMP., HUMIDITY	-20 ~ +85°C, 10 ~ 95% RH								
	TEMP. COEFFICIENT	0.03%/°C (0 ~ 50°C)								
	VIBRATION	10 ~ 500Hz, 2G 10min./1cycle, 60min. each along X, Y, Z axes								
SAFETY & EMC	SAFETY STANDARDS	UL60950-1 approved								
	WITHSTAND VOLTAGE	I/P-O/P:3KVAC		I/P-FG:1.5KVAC		O/P-FG:0.5KVAC				
	ISOLATION RESISTANCE	I/P-O/P, I/P-FG, O/P-FG:100M Ohms/500VDC								
OTHERS	MTBF	219.5K hrs min. MIL-HDBK-217F (25°C)								
	DIMENSION	150*140*86mm (L*W*H)								
	PACKING	1.4Kg; 8pcs/11.5Kg/0.97CUFT								
NOTE	<p>1. All parameters NOT specially mentioned are measured at 230VAC input, rated load and 25°C of ambient temperature.</p> <p>2. Ripple & noise are measured at 20MHz of bandwidth by using a 12" twisted pair-wire terminated with a 0.1uf & 47uf parallel capacitor.</p> <p>3. Tolerance : includes set up tolerance, line regulation and load regulation.</p>									

Mechanical Specification

Case No. 907C Unit:mm

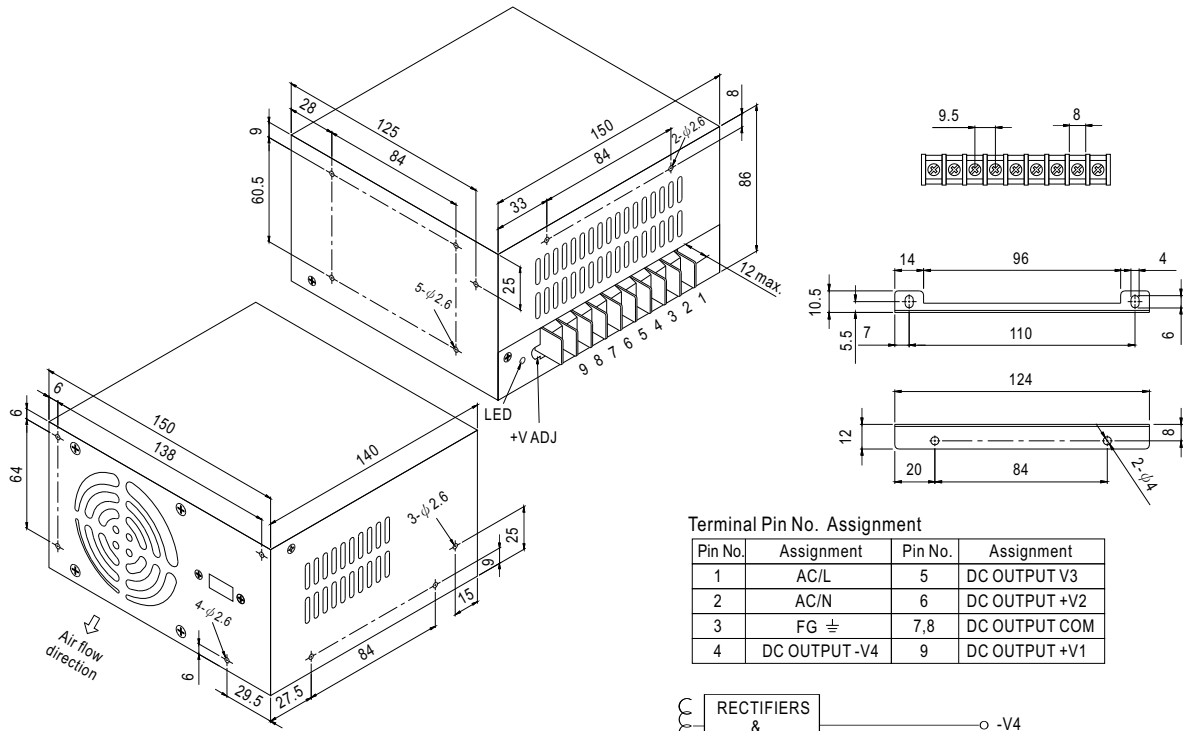

Block Diagram

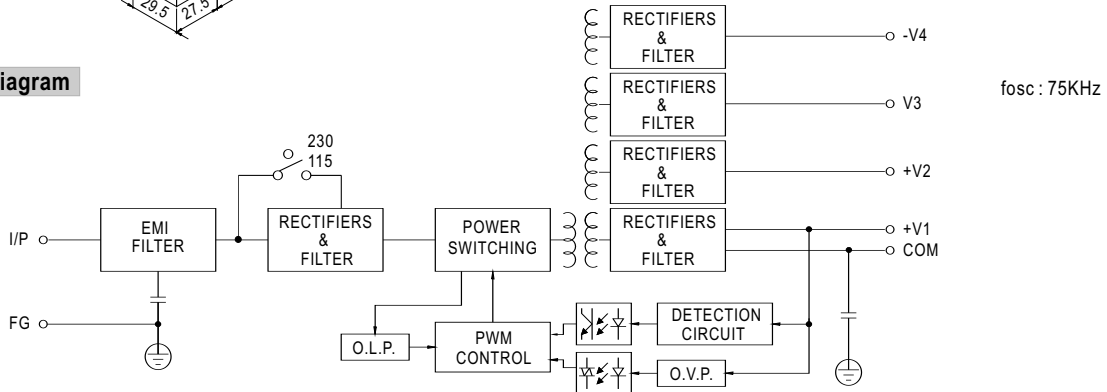

Derating Curve

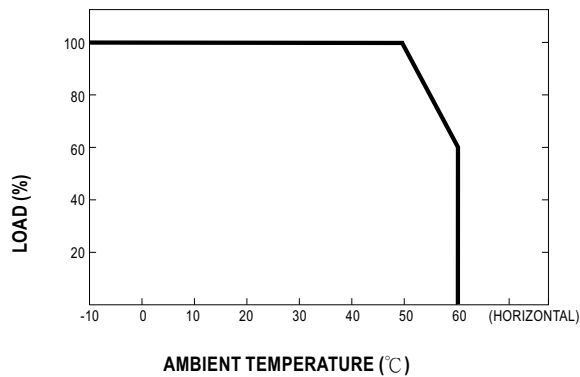

Static Characteristics (D,F)

