

Features :

- DC input active surge current limiting
- Wide 4:1~2:1 DC input range (24V: 19~72VDC, 96V:72~144VDC)
- Protections: Short circuit / Overload / Over voltage / Over temperature / Input polarity(by fuse)
- 2000VAC I/O Isolation
- Forced air cooling by built-in DC fan with fan speed control function
- Output OK Signal
- Built-in remote ON-OFF control
- Built-in remote sense function
- 3 years warranty

CB CE
SPECIFICATION

MODEL	SD-500L-12	SD-500L-24	SD-500L-48	SD-500H-12	SD-500H-24	SD-500H-48	
OUTPUT	DC VOLTAGE	12V	24V	48V	12V	24V	48V
	RATED CURRENT	40A	21A	10.5A	40A	21A	10.5A
	CURRENT RANGE	0 ~ 40A	0 ~ 21A	0 ~ 10.5A	0 ~ 40A	0 ~ 21A	0 ~ 10.5A
	RATED POWER	480W	504W	504W	480W	504W	504W
	RIPPLE & NOISE (max.) Note.2	150mVp-p	150mVp-p	150mVp-p	150mVp-p	150mVp-p	150mVp-p
	VOLTAGE ADJ. RANGE	11 ~ 15V	23 ~ 30V	46 ~ 60V	11 ~ 15V	23 ~ 30V	46 ~ 60V
	VOLTAGE TOLERANCE Note.3	±1.0%	±1.0%	±1.0%	±1.0%	±1.0%	±1.0%
	LINE REGULATION	±0.5%	±0.5%	±0.5%	±0.5%	±0.5%	±0.5%
	LOAD REGULATION	±0.5%	±0.5%	±0.5%	±0.5%	±0.5%	±0.5%
SETUP, RISE TIME	500ms, 50ms at full load						
INPUT	VOLTAGE RANGE Note.5	19 ~ 72VDC			72 ~ 144VDC		
	EFFICIENCY (Typ.)	86%	88%	89%	87%	89%	90%
	DC CURRENT (Typ.)	24.2A/19VDC	24.8A/24VDC	12A/48VDC	8A/72VDC	6A/96VDC	
	CURRENT (AT NO LOAD)	Max. 0.2A/48VDC			Max. 0.1A/96VDC		
	INRUSH CURRENT (Typ.)	60A/48VDC			60A/96VDC		
PROTECTION	OVERLOAD	105 ~ 125% rated output power Protection type : Constant current limiting, shut down o/p voltage after about 5 sec., re-power on to recover					
	OVER VOLTAGE	16 ~ 19V	30.8 ~ 35.2V	62 ~ 68V	16 ~ 19V	30.8 ~ 35.2V	62 ~ 68V
	OVER TEMPERATURE	80°C ±5°C (TSW1) detect on heatsink of power transistor 80°C ±5°C (L-48V,H-24V,H-48V), 85°C ±5°C (L-24V), 90°C ±5°C (L-12V), 95°C ±5°C (H-12V) (TSW2 : detect on heatsink of o/p diode) Protection type : Shut down o/p voltage, recovers automatically after temperature goes down					
FUNCTION	REMOTE ON/OFF CONTROL	Please refer to function manual					
	OUTPUT OK SIGNAL	Open collector signal low when PSU turns on, max. sink current :10mA					
ENVIRONMENT	WORKING TEMP.	-20 ~ +60°C (Refer to output load derating curve)					
	WORKING HUMIDITY	20 ~ 90% RH non-condensing					
	STORAGE TEMP., HUMIDITY	-40 ~ +85°C, 10 ~ 95% RH					
	TEMP. COEFFICIENT	±0.02%/°C (0 ~ 50°C)					
	VIBRATION	10 ~ 500Hz, 2G 10min./1cycle, 60min. each along X, Y, Z axes					
SAFETY & EMC (Note 4)	SAFETY STANDARDS	IEC60950-1 CB approved by TUV					
	WITHSTAND VOLTAGE	I/P-O/P:2KVAC I/P-FG:1.5KVAC O/P-FG:0.5KVAC					
	ISOLATION RESISTANCE	I/P-O/P, I/P-FG, O/P-FG:100M Ohms / 500VDC / 25°C / 70% RH					
	EMI CONDUCTION & RADIATION	Compliance to EN55022 (CISPR22) Class B					
	EMS IMMUNITY	Compliance to EN61000-4-2,3,4,6,8; ENV50204, light industry level, criteria A					
OTHERS	MTBF	196.3K hrs min. MIL-HDBK-217F (25°C)					
	DIMENSION	215*115*50mm (L*W*H)					
	PACKING	1.15Kg; 12pcs/14.8Kg/0.92CUFT					
NOTE	1. All parameters NOT specially mentioned are measured at 48, 96VDC input, rated load and 25°C of ambient temperature. 2. Ripple & noise are measured at 20MHz of bandwidth by using a 12" twisted pair-wire terminated with a 0.1uf & 47uf parallel capacitor. 3. Tolerance : includes set up tolerance, line regulation and load regulation. 4. The power supply is considered a component which will be installed into a final equipment. The final equipment must be re-confirmed that it still meets EMC directives. For guidance on how to perform these EMC tests, please refer to "EMI testing of component power supplies." (as available on http://www.meanwell.com) 5. Derating may be needed under low input voltages. Please check the derating curve for more details.						

Mechanical Specification

Case No. 912A Unit:mm

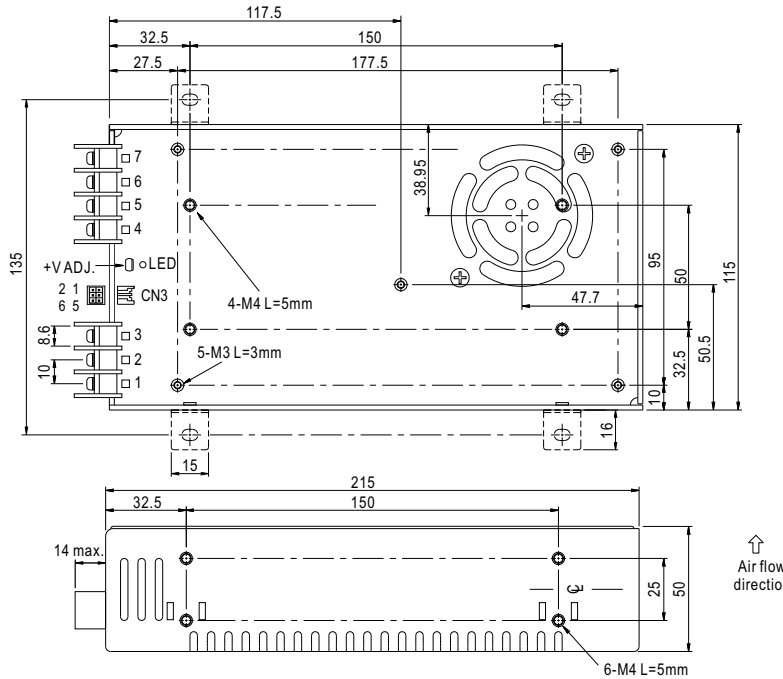

DC Input Terminal Pin No. Assignment

Pin No.	Assignment	Pin No.	Assignment
1	DC INPUT V+	4,5	-V
2	DC INPUT V-	6,7	+V
3	FG \perp		

Control Pin No. Assignment (CN3) : HRS DF11-6DP-2DS or equivalent

Pin No.	Assignment	Pin No.	Assignment	Mating Housing	Terminal
1	+S	4	GND	HRS DF11-6DS or equivalent	JST SPHD-002T-P0.5 or equivalent
2	-S	5	RC		
3	OUTPUT OK	6	RCG		

Block Diagram

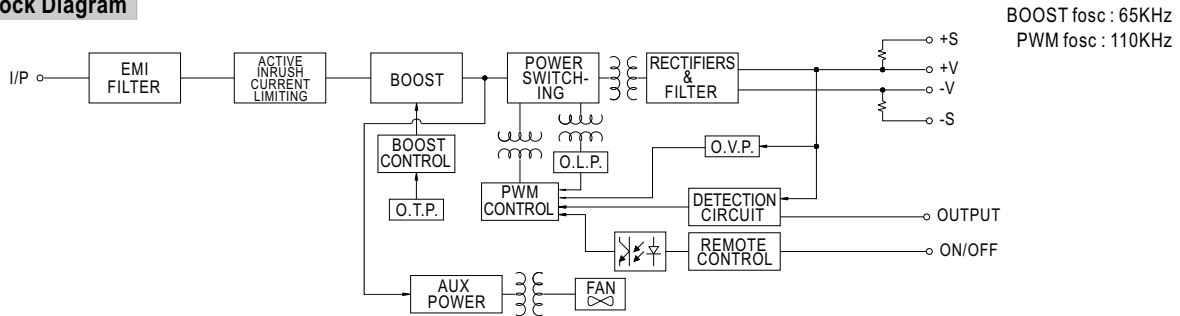

Derating Curve

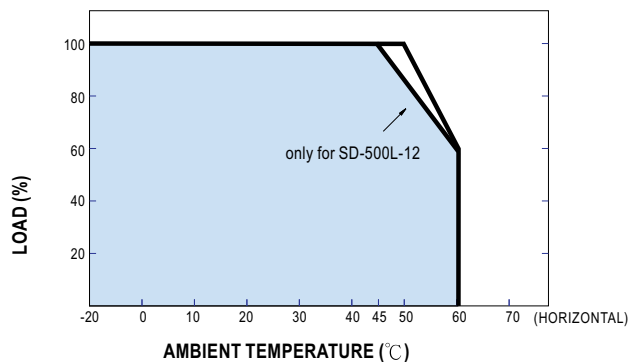

Static Characteristics

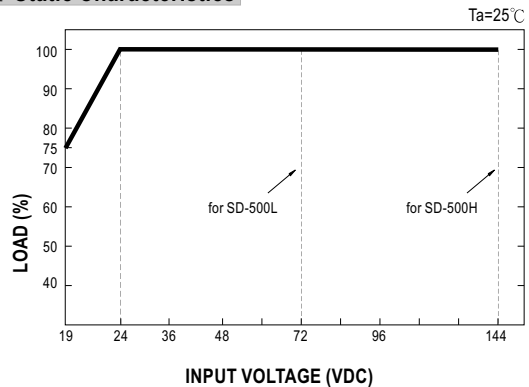

Function Description of CN3

Pin No.	Function	Description
1	+S	Positive sensing. The +S signal should be connected to the positive terminal of the load. The +S and -S leads should be twisted in pair to minimize noise pick-up effect. The maximum line drop compensation is 0.5V.
2	-S	Negative sensing. The -S signal should be connected to the negative terminal of the load. The -S and +S leads should be twisted in pair to minimize noise pick-up effect. The maximum line drop compensation is 0.5V.
3	O/P OK	Open collector signal, reference to pin4(GND). Low when PSU turns on. The maximum sink current is 10mA and the maximum external voltage is 13V.
4	GND	These pins connect to the negative terminal (-V).
5	RC	Remote ON/OFF
6	RCG	Remote ON/OFF ground

Function Manual

1.Remote ON/OFF

- (1) Remote ON/OFF control becomes available by applying voltage in CN3
- (2) Table 1.1 shows the specification of Remote ON/OFF function
- (3) Fig.1.2 shows the example to connect Remote ON/OFF control function

Table 1.1 Specification of Remote ON/OFF

Connection Method	Fig. 1.2(A)	Fig. 1.2(B)
Output on	SW Open	V=0~0.8Vdc
Output off	SW Close	V=4~10Vdc

Fig.1.2 Examples of connecting remote ON/OFF

(A) Using external voltage source

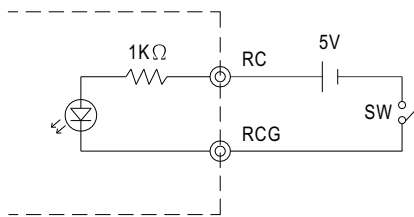

(B) Using external voltage source

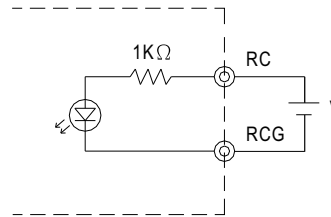

2.Output OK signal

"Output OK" is an open collector signal. It indicates the output status of the PSU. It can operate in two ways : One is sinking current from external signal ; the other is sending out a voltage signal.

2-1 Sink current :

The maximum sink current is 10mA and the maximum external voltage is 13V.

2-2 Voltage signal :

Between O/P OK(pin3) and GND(pin4)	Output Status
0 ~ 0.5V	ON
12 ~ 13V	OFF

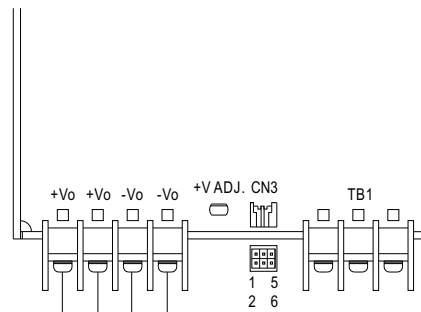

1	CN3	5
+S	O/P OK	RC
-S	GND	RCG
2		6

3. Remote Sense

The remote sensing compensates voltage drop on the load wiring up to 0.5V.

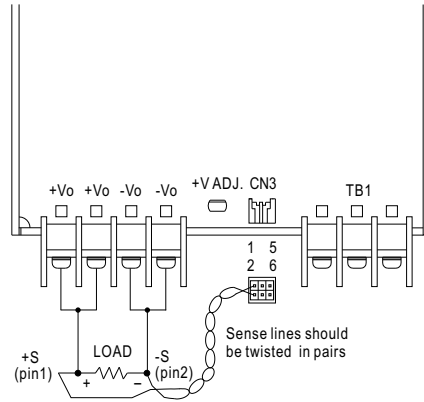

1	CN3	5
+S	O/P OK	RC
-S	GND	RCG
2		6