

THIS IS A C.A.D. GENERATED DRAWING
DO NOT MAKE MANUAL REVISIONS TO MASTER.

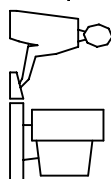

ISSUE NUMBER
ORIGINAL

1

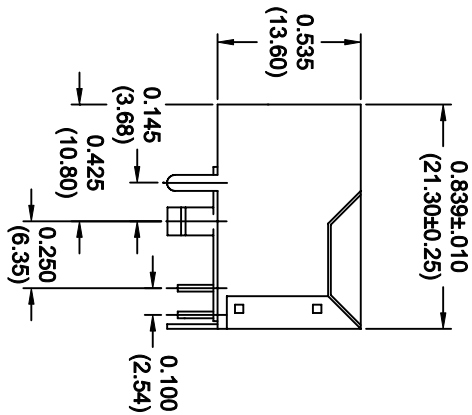
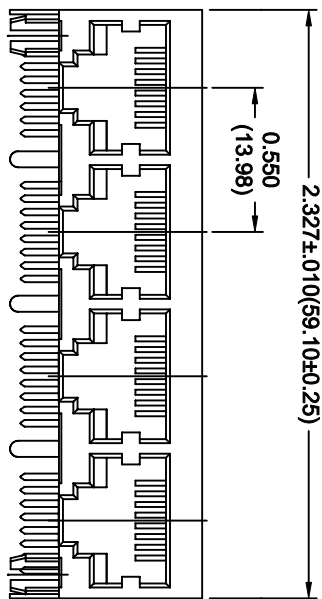

A00-432-262-450 GOLD FLASH
A00-432-362-450 15 MICRONS OF GOLD
A00-432-662-450 30 MICRONS OF GOLD
A00-432-962-450 50 MICRONS OF GOLD

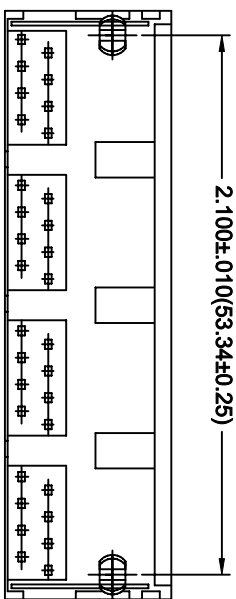

NOTES

MATERIAL AND FINISH:

BODY: GLASS FILLED POLYESTER,
UL94V-0 RATED
CONTACTS: PHOSPHOR BRONZE(0.45mm DIA.)
SELECTIVE GOLD ON CONTACTS AS PER PART NO. TABLE, TIN
ON TERMINATION, ALL OVER NICKEL UNDERPLATE.
SHIELD: 0.25mm THICK COPPER ALLOY
PLATED WITH NICKEL

ELECTRICAL CHARACTERISTICS:

- CONTACT RESISTANCE: 30 MILLIOHMS MAX.
- INSULATION RESISTANCE: 500 MEGOHMS MIN.
- WITHSTANDING VOLTAGE : 500 VAC 1 MINUTE
- CURRENT RATING: 1.5 AMP

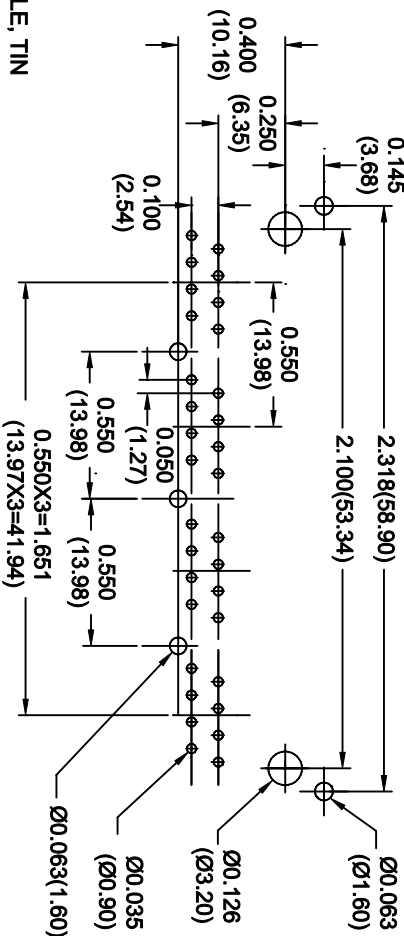

PC BOARD LAYOUT
COMPONENT SIDE SHOWN

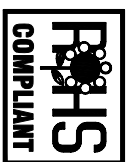

THIS SERIES FULLY CONFORMS TO THE
EUROPEAN UNION DIRECTIVES 2002/95/EC
AND 2002/96/EC FOR ROHS COMPLIANCY.

4 PORTS, 8 POSITIONS
SHIELDED PCB JACK (GROUND AT FRONT)



EDAC INC.
TORONTO, ONTARIO
CANADA
YOUR CONNECTION TO QUALITY & SERVICE

ARE THE PROPERTY OF EDAC INC. AND
SHOULD BE RETURNED TO EDAC INC.
ON THE DATE OF SALE OF APPARATUS
WITHOUT WRITTEN PERMISSION.

ACAD REF. DWG.:	A00-432-262-450
DRAWN: F. BRIONES	DATE: SEPT. 16/02
CHECKED:	DATE:
SCALE: N.T.S	SHEET 1 OF 1
DRAWING NUMBER	ISSUE

A00-432-262-450

2