

# OA162 Series

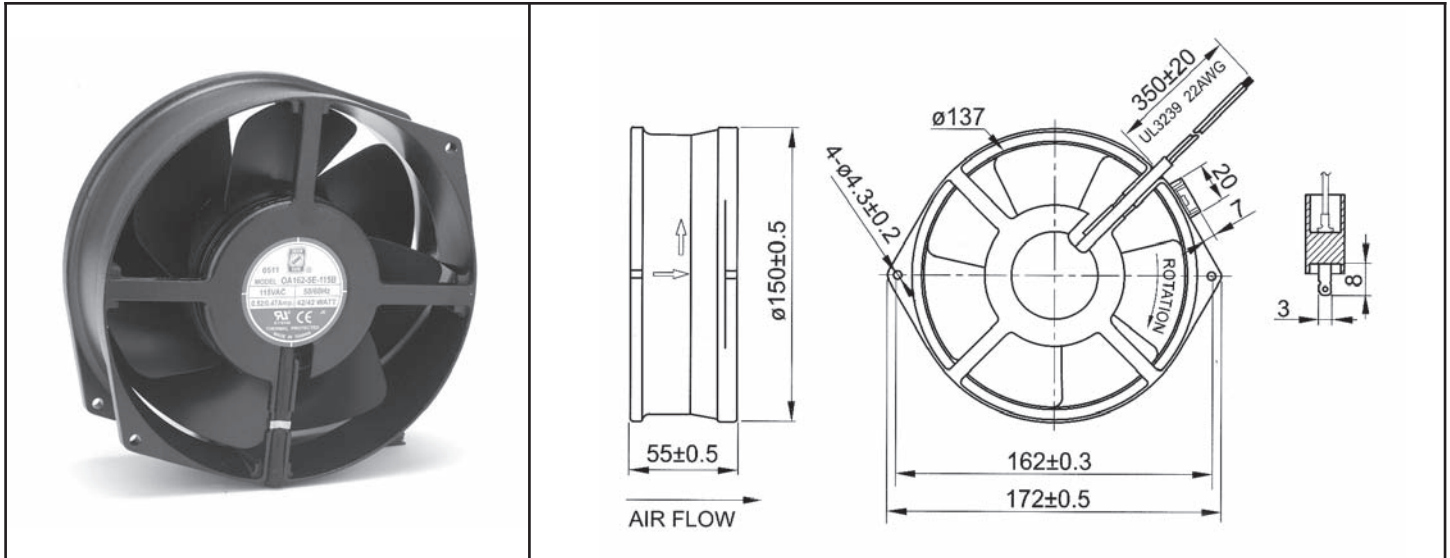

172 x 55mm  
(6.7" x 2.2")



Frame & Impeller	Diecast Aluminum	<u>Operating Temperature</u> Ball Bearing -40C ~ +70C  <u>Life Expectancy</u> Ball Bearing 60,000 hours (L10 at 40C)	
Connection	Terminals or Lead Wires		
Motor	Shaded Pole, thermally protected		
Bearing System	Dual ball (Sleeve available)		
Insulation Resistance	>100M ohm between lead-wire and frame (500VDC)		
Dielectric Strength	1 min at 1500 VAC, 50/60Hz		

Part Number	OA162-5E-115 * B	OA162-5E-230 * B
Nominal Voltage	120 VAC	230 VAC
Voltage Range	80 ~ 130 VAC	160 ~ 260 VAC
Rated Power	31 W (60Hz)	31 W (60Hz)
Rated Speed (RPM)	3400	3400
Airflow (CFM)	241	241
Noise Level (dB)	66	66
Max. Static Pressure	0.73" H <sub>2</sub> O	0.73" H <sub>2</sub> O

\* Indicate "T" for Terminal or "W" for Wire leads