

6300 Series

Tubeaxial

Ø 172 x 51mm



- DC fans with electronically commutated external rotor motor. Fully integrated commutation electronics. With electronic protection against reverse polarity and blocking; electronic motor current limitation in the start-up phase when rotor is blocked.
- Aluminium housing, impeller of fiber-glass reinforced plastic PA.
- Air exhaust over struts. Rotational direction CCW looking at rotor.
- Electrical connection via 2 flat pins 3 x 0.5 mm. Housing with ground lug for screw M4 x 8 (TORX).
- UL, CSA, VDE approvals on some models, please contact application engineering.
- Mounting from either face using two 4.3 mm holes.

Part Number	Curve	CFM @ 0	VDC	Volt. Range	Power (W)	dBA	Max Amb. Temp. C	Bearing Type	Wgt. (lbs)
6312/2TDHP	1	353.1	12	8 to 16	41	64	70	Ball	2.00
6314/2TDHP	1	353.1	24	16 to 36	41	64	70	Ball	2.00
6314/2TDHHP	2	417.9	24	16 to 36	67	69	70	Ball	2.00
6318/2TDHP	1	353.1	48	36 to 72	41	64	70	Ball	2.00
6318/2TDHHP	2	417.9	48	36 to 72	67	69	70	Ball	2.00
6318/2TDH4P	3	559.1	48	36 to 72	150	75	65	Ball	2.00

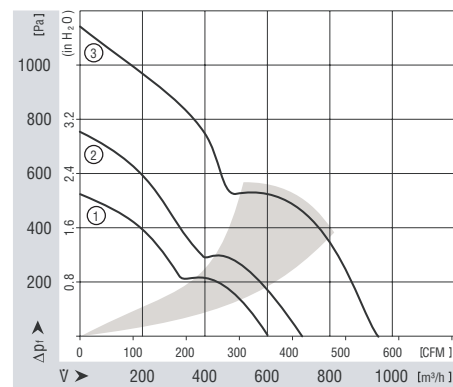
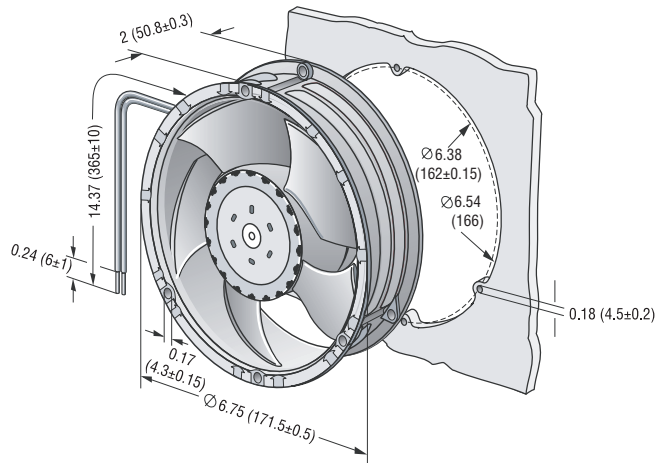

ebmpapst

e-mail: sales@us.ebmpapst.com · TEL: 860-674-1515 · FAX: 860-674-8536

ebm-papst Inc., 100 Hyde Road, Farmington, CT 06034 USA

ebm-papst Inc., 2007 © ebm-papst Inc. reserves the right to change any specifications or data without notice