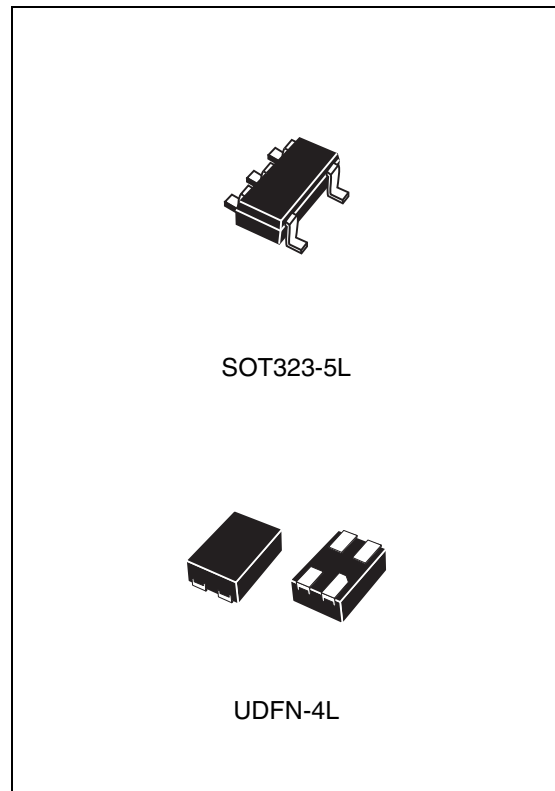

Ultra-low current 2.4 V precision analog temperature sensor

Features

- Precision analog voltage output temperature sensor
- ± 1.5 °C maximum temperature accuracy at 25 °C (± 0.5 °C typical)
- Ultra-low quiescent supply current: 4.8 μ A (typ) and 8.0 μ A (max)
- Operating voltage range: 2.4 V to 5.5 V
- Operating temperature range:
 - 55 °C to 130 °C (grade 7)
 - 40 °C to 85 °C (grade 9)
- SOT323-5L 5-lead package
- UDFN-4L 4-lead package

Applications

- Smartphones
- Multimedia PDA devices
- GPS devices
- Portable medical instruments
- Voltage-controlled crystal oscillator temperature monitors
- RF power transistor monitor



Contents

1	Description	5
2	Transfer function	6
3	Maximum ratings	8
4	DC and AC characteristics	9
5	Capacitive load	10
6	Typical operating characteristics	11
7	Package mechanical data	12
8	Part numbering	17
9	Revision history	18

List of tables

Table 1.	Signal names	5
Table 2.	First order equations optimized for different temperature ranges	6
Table 3.	Second order parabolic equation ($V_{CC} = 2.7\text{ V}$)	7
Table 4.	Second order parabolic equation for operation over the full voltage range ($V_{CC} = 2.4\text{ V to }5.5\text{ V}$)	7
Table 5.	Absolute maximum ratings	8
Table 6.	DC and AC characteristics	9
Table 7.	Resistor/capacitor combinations for the filter network	10
Table 8.	SOT323-5L – 5-lead small outline transistor package mechanical data	13
Table 9.	UDFN-4L – 4-lead (1.00 mm x 1.30 mm) package mechanical data	14
Table 10.	Carrier tape dimensions for SOT323-5L and UDFN-4L packages	15
Table 11.	Reel dimensions for 8 mm carrier tape - SOT323-5L and UDFN-4L packages	16
Table 12.	Ordering information scheme	17
Table 13.	Marking description	17
Table 14.	Document revision history	18

List of figures

Figure 1.	Logic diagram	5
Figure 2.	Connections (top view)	5
Figure 3.	Filter network for noisy environments or capacitive loads > 300 pF.	10
Figure 4.	V_{OUT} vs. temperature	11
Figure 5.	SOT323-5L – 5-lead small outline transistor package outline	13
Figure 6.	UDFN-4L – 4-lead (1.00 mm x 1.30 mm) package outline	14
Figure 7.	Carrier tape for SOT323-5L and UDFN-4L packages.	15
Figure 8.	Reel schematic	16

1 Description

The STLM20 is a precision analog output temperature sensor for low current applications where maximizing battery life is important. It operates over a $-55\text{ }^{\circ}\text{C}$ to $130\text{ }^{\circ}\text{C}$ (grade 7) or $-40\text{ }^{\circ}\text{C}$ to $85\text{ }^{\circ}\text{C}$ (grade 9) temperature range. The power supply operating range is 2.4 V to 5.5 V. The maximum temperature accuracy of the STLM20 is $\pm 1.5\text{ }^{\circ}\text{C}$ ($\pm 0.5\text{ }^{\circ}\text{C}$ typ) at an ambient temperature of $25\text{ }^{\circ}\text{C}$ and V_{CC} of 2.7 V. The temperature error increases linearly and reaches a maximum of $\pm 2.5\text{ }^{\circ}\text{C}$ at the temperature range extremes. The temperature range is affected by the power supply voltage. For the temperature grade 7 device, a power supply voltage of 2.7 V to 5.5 V, the temperature range extremes are $+130\text{ }^{\circ}\text{C}$ and $-55\text{ }^{\circ}\text{C}$ (decreasing the power supply voltage from 2.7 V to 2.4 V changes the low end of the operating temperature range from $-55\text{ }^{\circ}\text{C}$ to $-30\text{ }^{\circ}\text{C}$, while the positive remains at $+130\text{ }^{\circ}\text{C}$).

The STLM20 has a maximum quiescent supply current of $8\text{ }\mu\text{A}$. Therefore, self-heating is negligible.

Figure 1. Logic diagram

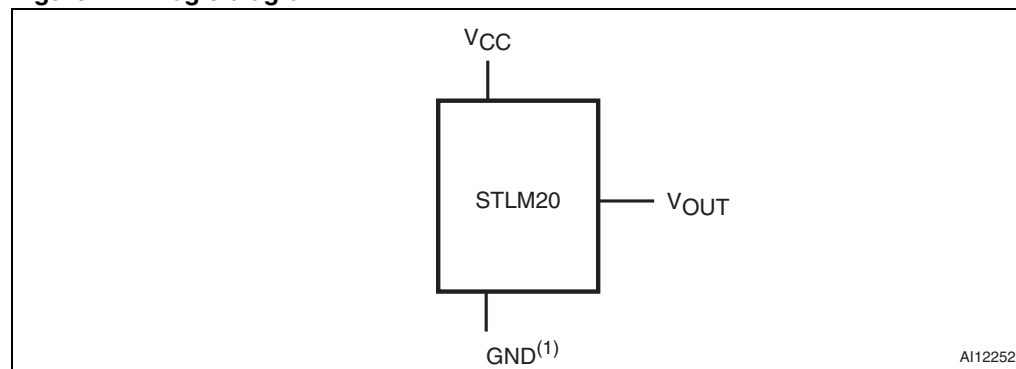

1. Pin 2 GND may be grounded or left floating (SOT323-5L only). For optimum thermal conductivity to the PC board ground plane, it should be grounded.

Table 1. Signal names

V_{CC}	Supply voltage
GND	Ground
V_{OUT}	Output voltage
NC	No connect

Figure 2. Connections (top view)

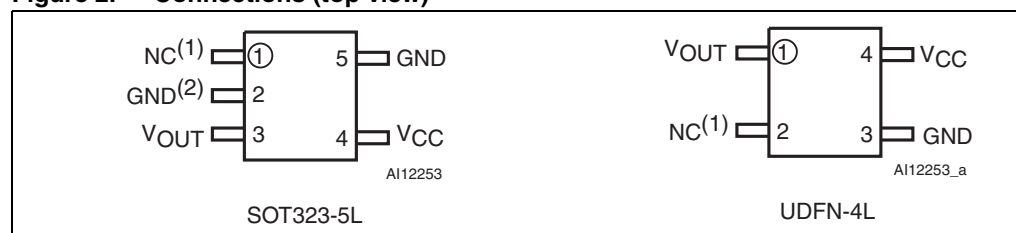

1. Pin 1 NC should be left floating or grounded.
2. Pin 2 GND may be grounded or left floating. For optimum thermal conductivity to the PC board ground plane, it should be grounded.

2 Transfer function

The STLM20's transfer function can be described in different ways, with varying levels of precision. A simple linear transfer function, with good accuracy near 25 °C is expressed as:

Equation 1 (first order linear equation)

$$V_O = (-11.69\text{mV})/^{\circ}\text{C} \times T + 1.8663\text{V}$$

Over the specified operating temperature range, the best accuracy can be obtained by using the parabolic transfer function:

Equation 2 (second order parabolic equation)

$$V_O = (-3.88 \times 10^{-6} \times T^2) + (-1.15 \times 10^{-2} \times T) + 1.8639$$

and solving for T:

$$T = -1481.96 + \sqrt{2.1962 \times 10^6 + \frac{(1.8639 - V_O)}{3.88 \times 10^{-6}}}$$

The best fit linear transfer function for many popular temperature ranges was calculated in [Table 2](#), where the error introduced by the linear transfer function increases with wider temperature ranges.

Table 2. First order equations optimized for different temperature ranges

Temperature range		Linear equation $V_O =$	Maximum deviation of linear equation from parabolic equation (°C)
T_{\min} (°C)	T_{\max} (°C)		
-55	130	$-11.79 \text{ mV}/^{\circ}\text{C} * T + 1.8528 \text{ V}$	± 1.41
-40	110	$-11.77 \text{ mV}/^{\circ}\text{C} * T + 1.8577 \text{ V}$	± 0.93
-30	100	$-11.77 \text{ mV}/^{\circ}\text{C} * T + 1.8605 \text{ V}$	± 0.70
-40	85	$-11.67 \text{ mV}/^{\circ}\text{C} * T + 1.8583 \text{ V}$	± 0.65
-10	65	$-11.71 \text{ mV}/^{\circ}\text{C} * T + 1.8641 \text{ V}$	± 0.23
35	45	$-11.81 \text{ mV}/^{\circ}\text{C} * T + 1.8701 \text{ V}$	± 0.004
20	30	$-11.69 \text{ mV}/^{\circ}\text{C} * T + 1.8663 \text{ V}$	± 0.004

Table 3. Second order parabolic equation ($V_{CC} = 2.7\text{ V}$)

Parameter	Conditions	Min	Typ	Max	Unit
Temperature error based on: $V_{OUT} = (-3.88 \times 10^{-6} \times T^2) + (-1.15 \times 10^{-2} \times T) + 1.8639$ where T is the temperature	$T_A = -55\text{ }^\circ\text{C}$	2.457	2.485	2.512	V
	$T_A = -40\text{ }^\circ\text{C}$	2.292	2.318	2.343	
	$T_A = -30\text{ }^\circ\text{C}$	2.181	2.205	2.230	
	$T_A = -20\text{ }^\circ\text{C}$	2.069	2.092	2.116	
	$T_A = 0\text{ }^\circ\text{C}$	1.842	1.864	1.886	
	$T_A = 25\text{ }^\circ\text{C}$	1.556	1.574	1.592	
	$T_A = 50\text{ }^\circ\text{C}$	1.255	1.279	1.303	
	$T_A = 85\text{ }^\circ\text{C}$	0.833	0.859	0.884	
	$T_A = 130\text{ }^\circ\text{C}$	0.272	0.303	0.335	

Table 4. Second order parabolic equation for operation over the full voltage range ($V_{CC} = 2.4\text{ V to } 5.5\text{ V}$)

Parameter ⁽¹⁾	Conditions	Min	Max	Unit
Temperature error based on: $V_{OUT} = (-3.88 \times 10^{-6} \times T^2) + (-1.15 \times 10^{-2} \times T) + 1.8639$, where T is the temperature	$T_A = -55\text{ }^\circ\text{C}^{(2)(3)}$	2.457	2.531	V
	$T_A = -40\text{ }^\circ\text{C}^{(2)}$	2.292	2.362	
	$T_A = -30\text{ }^\circ\text{C}$	2.180	2.249	
	$T_A = -20\text{ }^\circ\text{C}$	2.068	2.135	
	$T_A = 0\text{ }^\circ\text{C}$	1.841	1.904	
	$T_A = 25\text{ }^\circ\text{C}$	1.555	1.610	
	$T_A = 50\text{ }^\circ\text{C}$	1.254	1.322	
	$T_A = 85\text{ }^\circ\text{C}$	0.832	0.903	
	$T_A = 130\text{ }^\circ\text{C}^{(3)}$	0.271	0.353	

1. V_{OUT} tolerance is $\pm 4\%$ (temperature grade 9 only).
2. Valid for V_{CC} min = 2.7 V.
3. Valid for temperature grade 7 only.

3 Maximum ratings

Stressing the device above the rating listed in the absolute maximum ratings table may cause permanent damage to the device. These are stress ratings only and operation of the device at these or any other conditions above those indicated in the operating sections of this specification is not implied. Exposure to absolute maximum rating conditions for extended periods may affect device reliability.

Table 5. Absolute maximum ratings

Symbol	Parameter	Value	Unit	
T_{STG}	Storage temperature	-65 to +150	°C	
$T_{SLD}^{(1)}$	Lead solder temperature for 10 seconds	260	°C	
V_O	Output voltage	-0.3 to $V_{CC} + 0.3$	V	
V_{CC}	Supply voltage	-0.2 to 6.5	V	
I_O	Output current	10	mA	
$T_{J(max)}$	Maximum junction temperature	150	°C	
θ_{JA}	Thermal resistance	SOT323-5L	331.4	°C/W
		UDFN-4L	160.2	°C/W
$T_A^{(2)}$	Ambient operating temperature	Grade 7	-55 to 130	°C
		Grade 9	-40 to 85	°C

1. Reflow at peak temperature of 260 °C. The time above 255 °C must not exceed 30 seconds.
2. Grade 7: STLM20W87F
Grade 9: STLM20DD9F

4 DC and AC characteristics

This section summarizes the DC and AC characteristics of the device. The parameters in the DC and AC characteristics table that follows are derived from tests performed under the test conditions. Designers should check that the operating conditions in their circuit match the operating conditions when relying on the quoted parameters.

Table 6. DC and AC characteristics

Sym	Description	Test condition ⁽¹⁾	Min	Typ ⁽²⁾	Max	Unit
V _{CC}	Supply voltage	T _A = -30 °C to 130 °C	2.4		5.5	V
		T _A = -55 °C to 130 °C or -40 °C to 85 °C	2.7		5.5	V
V _O	Output voltage	T _A = 0 °C		1.8639		V
	Second order parabolic equation Temperature to voltage error ⁽³⁾ V _O = (-3.88 × 10 ⁻⁶ × T ²) + (-1.15 × 10 ⁻² × T) + 1.8639 V	T _A = 125 °C to 130 °C			±2.5	°C
		T _A = 80 °C to 85 °C		±1.00	±2.1	°C
		T _A = 25 °C to 30 °C		±0.5	±1.5	°C
		T _A = 0 °C		±0.75	±1.9	°C
		T _A = -40 °C			±2.3	°C
		T _A = -55 °C			±2.5	°C
I _Q	Quiescent current	2.4 V ≤ V _{CC} ≤ 5.5 V		4.8	8	μA
	Sensor gain (temperature sensitivity or average slope), V _O = -11.77 mV/°C × T + 1.860 V	-30 °C ≤ T _A ≤ 100 °C	-11.4	-11.77	-12.2	mV/°C
	Non-linearity	-20 °C ≤ T _A ≤ 80 °C		±0.4		%
ΔI _Q	Change of quiescent current	2.4 V ≤ V _{CC} ≤ 5.5 V		0.7		μA
T _C V _O	Temperature coefficient of quiescent current			-11		nA/°C
I _{SD}	Shutdown current	V _{CC} ≤ 0.8 V		0.02		μA
Z _O	Output impedance	0 μA ≤ I _L ≤ 16 μA ⁽⁴⁾⁽⁵⁾			160	Ω
RegL	Load regulation ⁽⁶⁾				-2.5	mV
Reg1	Line regulation	2.4 V ≤ V _{CC} ≤ 5.0 V			3.3	mV/V
Reg2		5.0 V ≤ V _{CC} ≤ 5.5 V			11	mV

- Valid for ambient operating temperature: T_A = -55 to 130 °C or T_A = -40 to 85 °C; V_{CC} = 2.7 V (except where noted).
- T_J = T_A = 25 °C, unless otherwise noted under test condition.
- Accuracy is defined as the error between the measured and calculated output voltage at specified conditions of voltage, current, and temperature.
- Positive load currents flow out of the device (sourcing) and can typically be 16 μA. For negative load currents (sinking), the device can sink less than 1 μA.
- Over the supply range of 2.4 to 5.5 V.
- Measured at constant junction temperature, with pulse testing and low duty cycle. Output changes due to heating may be calculated by multiplying internal dissipation by thermal resistance.

5 Capacitive load

The STLM20 will handle capacitive loads of up to 300 pF. Over the specified temperature range, the STLM20 has a maximum output impedance of 160 Ω .

In a noisy environment, it may be advisable to add some filtering to minimize noise in the output voltage. A 0.1 μF capacitor added between the supply voltage and ground is recommended.

In an extremely noisy environment, it may be necessary to add a low-pass filter network to the output of the device. A 1 μF capacitor, in addition to the output impedance of the device, and a 200 Ω series resistor, will provide a low-pass filter that will pass the slow thermal time constant of the STLM20, while filtering the higher frequency noise.

Figure 3. Filter network for noisy environments or capacitive loads > 300 pF

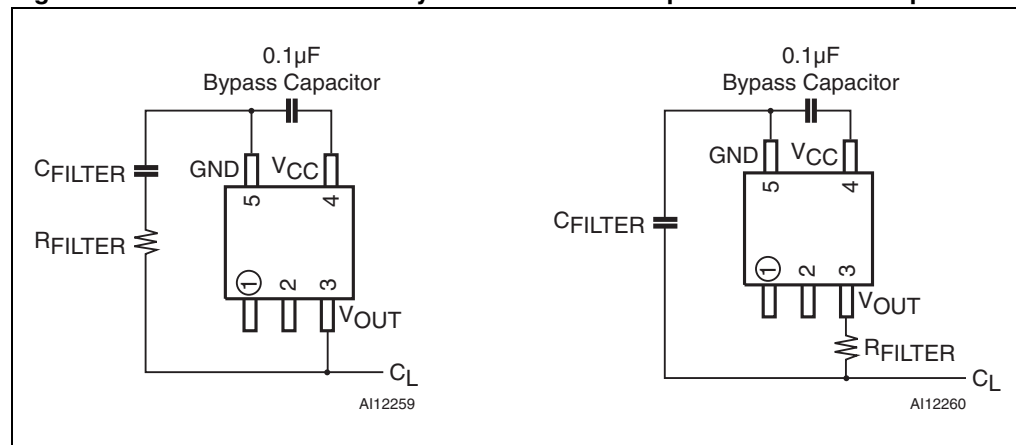

Table 7. Resistor/capacitor combinations for the filter network

R_{FILTER}	C_{FILTER}
200 Ω	1 μF
470 Ω	0.1 μF
680 Ω	0.01 μF
1000 Ω	1000 pF
10 k Ω	100 pF
100 k Ω	10 pF

6 Typical operating characteristics

The graph shown in [Figure 4](#) represents V_{OUT} according to temperature.

Figure 4. V_{OUT} vs. temperature

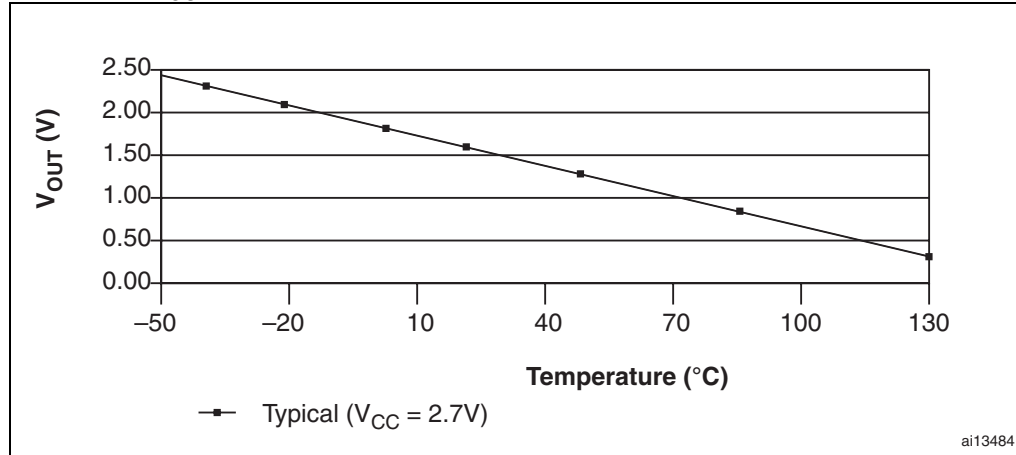

7 Package mechanical data

In order to meet environmental requirements, ST offers these devices in different grades of ECOPACK[®] packages, depending on their level of environmental compliance. ECOPACK[®] specifications, grade definitions and product status are available at: www.st.com. ECOPACK[®] is an ST trademark.

Figure 5. SOT323-5L – 5-lead small outline transistor package outline

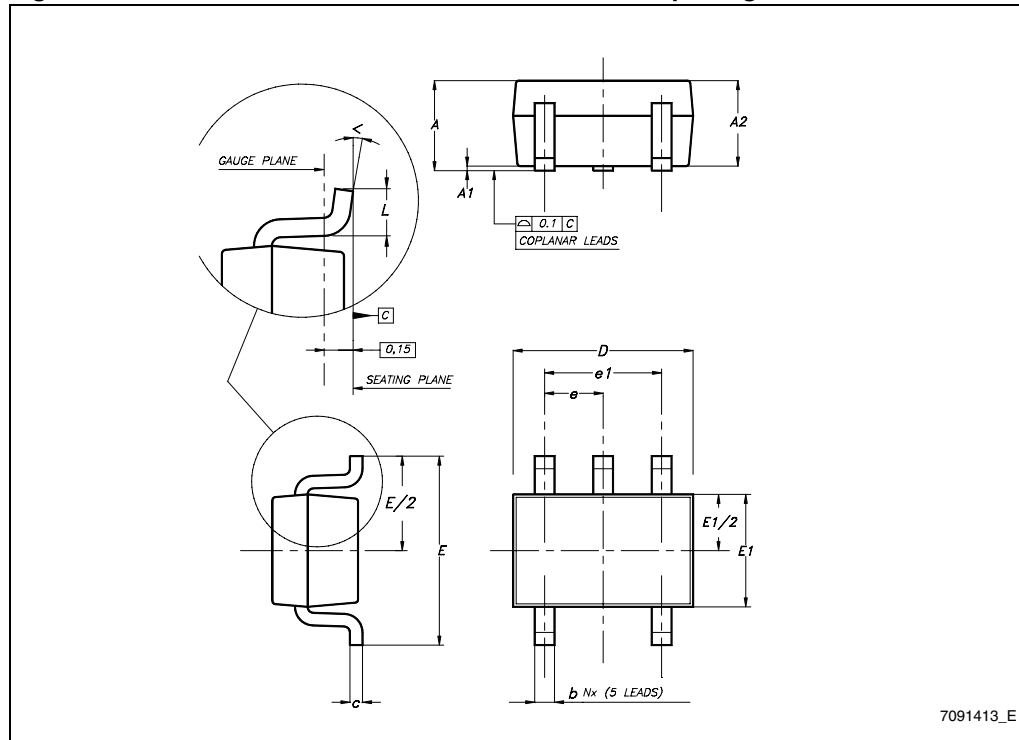

7091413_E

1. Drawing is not to scale.

Table 8. SOT323-5L – 5-lead small outline transistor package mechanical data

Symbol	mm			inches		
	Typ	Min	Max	Typ	Min	Max
A	–	0.80	1.10	–	0.031	0.043
A1	–	0	0.10	–	0.000	0.004
A2	0.90	0.80	1.00	0.035	0.031	0.039
b	–	0.15	0.30	–	0.006	0.012
c	–	0.10	0.22	–	0.004	0.009
D	2.00	1.80	2.20	0.079	0.071	0.087
E	2.10	1.80	2.40	0.083	0.071	0.094
E1	1.25	1.15	1.35	0.049	0.045	0.053
e	0.65	–	–	0.026	–	–
e1	1.30	–	–	0.051	–	–
L	0.36	0.26	0.46	0.014	0.010	0.018
α	–	0°	8°	–	0°	8°

Figure 6. UDFN-4L – 4-lead (1.00 mm x 1.30 mm) package outline

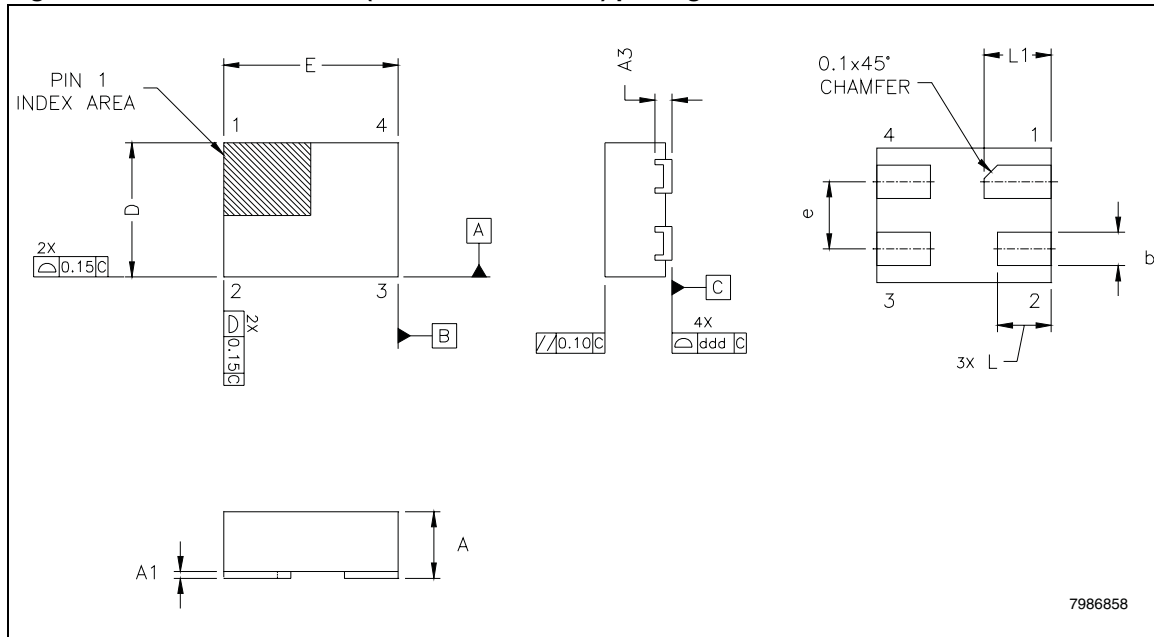

Note: Drawing is not to scale.

Table 9. UDFN-4L – 4-lead (1.00 mm x 1.30 mm) package mechanical data

Symbol	mm			inches		
	Min	Typ	Max	Min	Typ	Max
A	0.45	0.50	0.55	0.018	0.020	0.022
A1	0	0.025	0.05	0	0.001	0.002
A3	0.119	0.127	0.177	0.0046	0.0050	0.0069
b	0.20	0.25	0.30	0.008	0.010	0.012
D	0.95	1.00	1.05	0.037	0.039	0.041
E	1.25	1.30	1.35	0.049	0.051	0.053
e	0.45	0.50	0.55	0.018	0.020	0.022
L	0.35	0.40	0.45	0.014	0.016	0.018
L1	0.45	0.50	0.55	0.018	0.020	0.022
ddd	0	0.04	0.08	0	0.0016	0.0031

Figure 7. Carrier tape for SOT323-5L and UDFN-4L packages

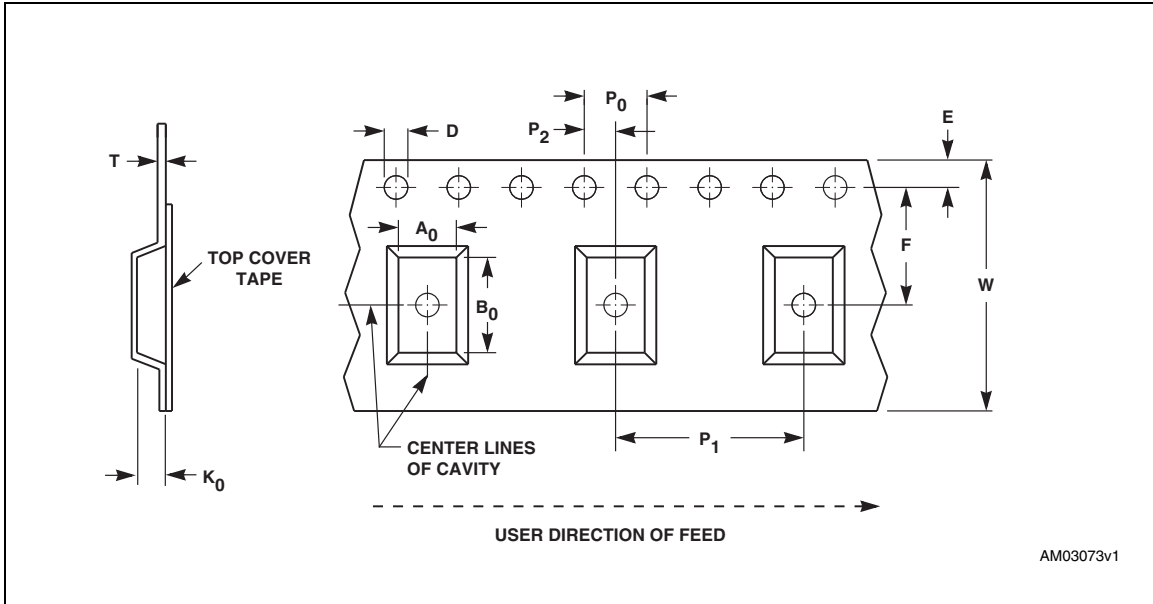

Table 10. Carrier tape dimensions for SOT323-5L and UDFN-4L packages

Package	W	D	E	P ₀	P ₂	F	A ₀	B ₀	K ₀	P ₁	T	Unit	Bulk Qty
SOT323-5L	8.00 +0.30 -0.10	1.50 +0.10/ -0.00	1.75 ±0.10	4.00 ±0.10	2.00 ±0.10	3.50 ±0.05	2.25 ±0.10	2.40 ±0.10	1.22 ±0.10	4.00 ±0.10	0.30 ±0.05	mm	3000
UDFN-4L	8.00 +0.30 -0.10	1.50 +0.10/ -0.00	1.75 ±0.10	4.00 ±0.10	2.00 ±0.10	3.50 ±0.05	1.25 ±0.10	1.55 ±0.10	0.65 ±0.05	4.00 ±0.10	0.250 ±0.05	mm	3000

Figure 8. Reel schematic

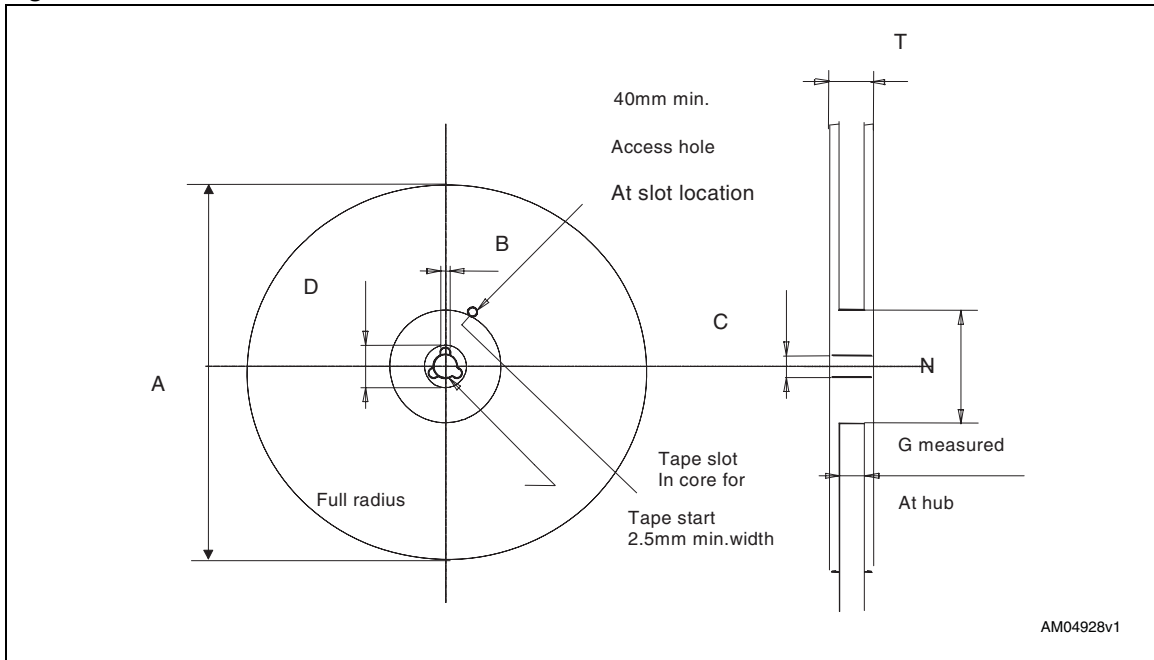

Table 11. Reel dimensions for 8 mm carrier tape - SOT323-5L and UDFN-4L packages

A (max)	B (min)	C	D (min)	N (min)	G	T (max)
180 mm (7-inch)	1.5 mm	13 mm ± 0.2 mm	20.2 mm	60 mm	8.4 mm + 2/-0 mm	14.4 mm

Note: The dimensions given in [Table 11](#) incorporate tolerances that cover all variations on critical parameters.

8 Part numbering

Table 12. Ordering information scheme

Example:	STLM20	DD	9	F
Device type				
STLM20				
Package				
W8 = SOT323-5L ⁽¹⁾⁽²⁾				
DD= UDFN-4L - ultra-thin DFN 4-lead ⁽³⁾				
Temperature range				
7 = -55 to 130°C				
9 = -40 to 85°C				
Shipping method				
F = ECOPACK® package, tape & reel				

1. Available in temperature grade 7 (-55 to 130 °C) only
2. SOT323-5L also referred to as SC70-5L
3. Available in temperature grade 9 (-40 to 85 °C) only

Table 13. Marking description

Part number	Package	Marking
STLM20W87F	SOT323-5L	M20
STLM20DD9F	UDFN-4L	20

For other options, or for more information on any aspect of this device, please contact the ST sales office nearest you.

9 Revision history

Table 14. Document revision history

Date	Revision	Changes
28-Jun-2006	1	Initial release.
19-Jul-2006	2	Added Table 13: Marking description
28-Aug-2006	3	Added a footnote concerning package availability in Features on page 1 and to Table 12 and Table 13 ; updated package mechanical data in Table 9
05-Sep-2006	4	Amended text in the Features on page 1, Section 1: Description, Section 2: Transfer function, Table 6, and Table 12 to elucidate that two packages exist each with specific temperature ranges: SOT323-5 (SC70-5) 5-lead package (–55 to 130 °C) and UDFN 4-lead package (–40 to 85 °C)
25-Sep-2006	5	Updated operating temperature ranges (now 7 and 9); updated Table 6: DC and AC characteristics
10-Oct-2006	6	Table 3: Second order parabolic equation ($V_{CC} = 2.7 V$) and Table 4: Second order parabolic equation for operation over the full voltage range ($V_{CC} = 2.4 V$ to $5.5 V$) added. Section 6: Typical operating characteristics added. T_A added to Table 5: Absolute maximum ratings .
04-Dec-2006	7	Document status updated to full datasheet; updated text in the title of Table 4: Second order parabolic equation for operation over the full voltage range ($V_{CC} = 2.4 V$ to $5.5 V$) ; added footnotes regarding temperature ranges in Table 12: Ordering information scheme .
08-Feb-2007	8	Added thermal resistance in Table 5: Absolute maximum ratings .
09-May-2007	9	Modified Equation 1, 2 .
26-Nov-2007	10	Updated footnote 2 in Table 5 ; minor text updates.
07-Nov-2008	11	Updated Figure 6: UDFN-4L – 4-lead (1.00 mm x 1.30 mm) package outline to reflect location of pin 1 with respect to the orientation of the topside marking; updated Figure 5, Table 5, 8, 12 .
10-Sep-2009	12	Updated Table 5 , text in Section 7: Package mechanical data ; added tape and reel specifications (Figure 7 and Table 10); reformatted document.
09-Jul-2010	13	Updated Features, Section 1: Description, Section 2: Transfer function, Table 5, 6, 12 ; added reel information (Figure 8, Table 11); removed references to SC70-5L package; minor textual changes.

Please Read Carefully:

Information in this document is provided solely in connection with ST products. STMicroelectronics NV and its subsidiaries ("ST") reserve the right to make changes, corrections, modifications or improvements, to this document, and the products and services described herein at any time, without notice.

All ST products are sold pursuant to ST's terms and conditions of sale.

Purchasers are solely responsible for the choice, selection and use of the ST products and services described herein, and ST assumes no liability whatsoever relating to the choice, selection or use of the ST products and services described herein.

No license, express or implied, by estoppel or otherwise, to any intellectual property rights is granted under this document. If any part of this document refers to any third party products or services it shall not be deemed a license grant by ST for the use of such third party products or services, or any intellectual property contained therein or considered as a warranty covering the use in any manner whatsoever of such third party products or services or any intellectual property contained therein.

UNLESS OTHERWISE SET FORTH IN ST'S TERMS AND CONDITIONS OF SALE ST DISCLAIMS ANY EXPRESS OR IMPLIED WARRANTY WITH RESPECT TO THE USE AND/OR SALE OF ST PRODUCTS INCLUDING WITHOUT LIMITATION IMPLIED WARRANTIES OF MERCHANTABILITY, FITNESS FOR A PARTICULAR PURPOSE (AND THEIR EQUIVALENTS UNDER THE LAWS OF ANY JURISDICTION), OR INFRINGEMENT OF ANY PATENT, COPYRIGHT OR OTHER INTELLECTUAL PROPERTY RIGHT.

UNLESS EXPRESSLY APPROVED IN WRITING BY AN AUTHORIZED ST REPRESENTATIVE, ST PRODUCTS ARE NOT RECOMMENDED, AUTHORIZED OR WARRANTED FOR USE IN MILITARY, AIR CRAFT, SPACE, LIFE SAVING, OR LIFE SUSTAINING APPLICATIONS, NOR IN PRODUCTS OR SYSTEMS WHERE FAILURE OR MALFUNCTION MAY RESULT IN PERSONAL INJURY, DEATH, OR SEVERE PROPERTY OR ENVIRONMENTAL DAMAGE. ST PRODUCTS WHICH ARE NOT SPECIFIED AS "AUTOMOTIVE GRADE" MAY ONLY BE USED IN AUTOMOTIVE APPLICATIONS AT USER'S OWN RISK.

Resale of ST products with provisions different from the statements and/or technical features set forth in this document shall immediately void any warranty granted by ST for the ST product or service described herein and shall not create or extend in any manner whatsoever, any liability of ST.

ST and the ST logo are trademarks or registered trademarks of ST in various countries.

Information in this document supersedes and replaces all information previously supplied.

The ST logo is a registered trademark of STMicroelectronics. All other names are the property of their respective owners.

© 2010 STMicroelectronics - All rights reserved

STMicroelectronics group of companies

Australia - Belgium - Brazil - Canada - China - Czech Republic - Finland - France - Germany - Hong Kong - India - Israel - Italy - Japan - Malaysia - Malta - Morocco - Philippines - Singapore - Spain - Sweden - Switzerland - United Kingdom - United States of America

www.st.com

