

Dimensions: mm (In.)

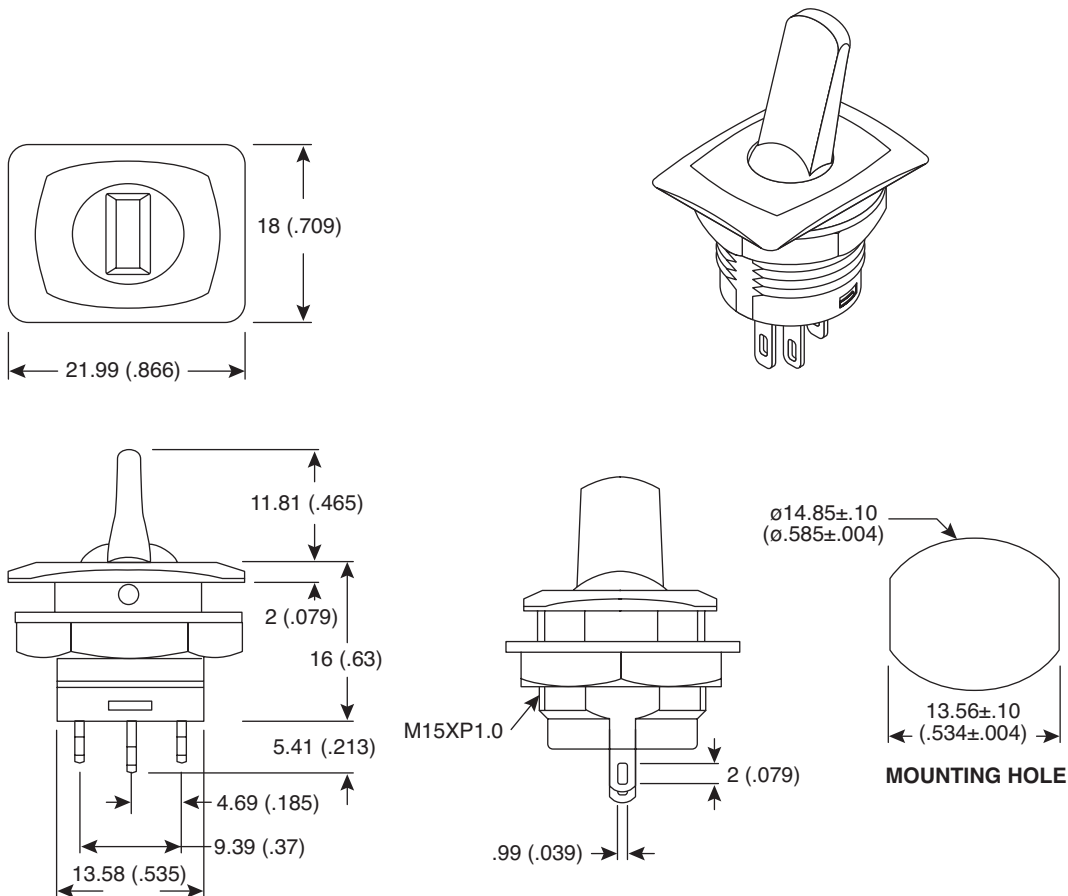

Electrical Specifications:

- Rating: 6A/125VAC, 3A/250VAC
- Contact resistance: 50m Ω max.
- Insulation resistance: 500VDC 100M Ω min.
- Dielectric strength: 1500VAC for 1 minute

Mechanical Specifications:

- Switching function: 3P SPDT On-On

Note:

- RoHS Compliant

Toggle Switch
103-4023-EV

